

Making sense of technology

A well established high tech Danish enterprise, founded in 1975, has become one of the most sought after high performance sensor manufacturers in the world. Telco's global success is the result of many years of listening to the experts – our customers.

All Telco sensors are manufactured in-house by skilled employees together with advanced automated production equipment. The strictest quality standards guarantee that both components and the finished product have undergone comprehensive quality inspections at each production stage achieving unmatched technical superiority.

Telco's wide range of sensors are typically used for counting, sorting, measuring, positioning and detecting within, but not limited to, the industries of steel, wood, packaging, material handling, bottling, agriculture, car wash, elevators, escalators and automatic doors. All Telco sensors are tolerant of hostile environments and are consequently the most versatile on the market with a 3 year world-wide warranty.

Telco is proudly represented by its own renowned subsidiaries and qualified representatives world-wide who provide 24 hour service with stock, just in time delivery, technical and on site application support.

Contact your local Telco representative today.



| Contents | |
|---|---------|
| Remote Photoelectric Systems | |
| ■ Remote Sensors | page 3 |
| ■ PA 01 | page 7 |
| ■ PA 09 | page 9 |
| ■ PA 10 | page 11 |
| ■ PA 11 | page 13 |
| ■ MPA 21 | page 15 |
| ■ MPA 41 | page 17 |
| ■ MPA 81 | page 21 |
| Self-Contained Photoelectric Systems | |
| ■ SpaceMaster™ 3000 | page 25 |
| ■ SpaceMaster™ 6000 | page 29 |
| ■ SpaceMaster™ 7000 | page 33 |
| ■ SpaceMaster™ 8000 | page 37 |
| ■ Power Packs | page 41 |
| General | |
| ■ Fibre Optics | page 43 |
| ■ Accessories | page 47 |
| ■ Glossary | page 49 |

Remote Sensor Series

Description

- Operation mode and max sensing range:
Thru beam: Dependant on amplifier
Diffuse proximity: Dependant on amplifier
- Optional sensor monitor LED
- Wide variety of housings
- High tolerance to hostile environments
- Cable or plug connections

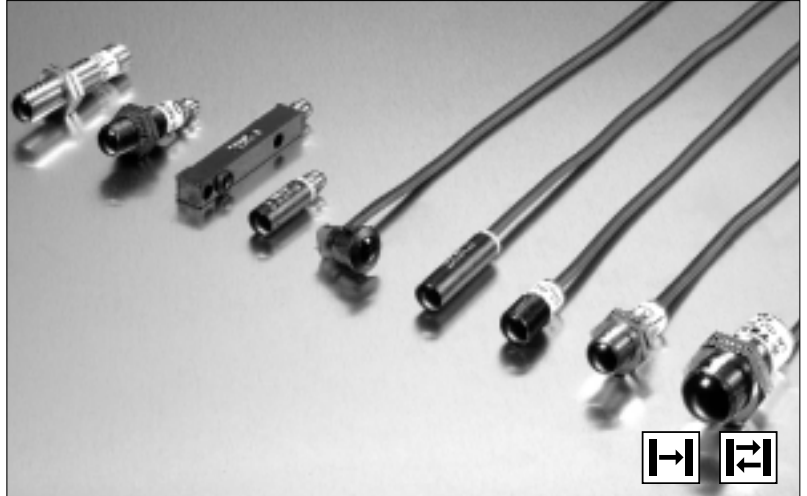

The remote sensor series, which consists of a transmitter LT and receiver LR, is made to operate in conjunction with a Telco photoelectric amplifier from the PA or MPA programmes.

The remote sensors are available in a wide range of housings, with either cable or plug connection, and may be used in thru beam or diffuse proximity mode.

The series is available with optional power-(LR) and output-(LT) monitor LEDs for use with any Telco photoelectric amplifier which has the sensor LED drive feature incorporated.

Technical Data

| | LT | LR |
|---------------------------|--------------------------|-----------------------------------|
| Transmitter Diode | Ga Al As, (880 nm) | - |
| Photo Transistor | - | Silicon NPN |
| Cable Ø 4mm PVC Sleeves | 2 x 0,25 mm ² | 1 x 0,25 mm ² + shield |
| Min. cable bending radius | 45 mm | |

Environmental Data

| | | |
|---------------------------------|--|--|
| Vibration | 10 – 55 Hz, 0,5 mm | |
| Shock | 30 g | |
| Light immunity, @ 20° incidence | 101 Series 100 Series 110/120 Series | >50 000 lux >80 000 lux >100 000 lux |
| Temperature, operation | – 25 to +65 °C | |
| Temperature, storage | – 40 to +80 °C | |
| Sealing Class | IP 67 | |
| Approvals | CE | |

Available Types

| | Series | Optical Angle | Connection | | 5 m Cable | 15 m Cable | 3 pin, M8 Plug | 4 pin, M12 Plug |
|--------------------|------------|---------------|---------------------|-------------------------|----------------------|-----------------------|-----------------------|---------------------|
| | | | Housing Material | Housing Size | | | | |
| Transmitter | 101 | +/- 8° | Polycarbonate | Ø10 | LT 101 AP25 5 | LT 101 AP25 15 | LT 101 AP25 T3 | - |
| | | | | M12 x 1 | LT 101 TP25 5 | LT 101 TP25 15 | LT 101 TP25 T3 | - |
| | | | Nickel Plated Brass | | LT 101 TB25 5 | LT 101 TB25 15 | LT 101 TB25 T3 | - |
| | | | Stainless Steel | | LT 101 TS25 5 | LT 101 TS25 15 | LT 101 TS25 T3 | - |
| | | | Polyester | | □ 9,5 x 11,5 | LT 101 SG 5* | LT 101 SG 15* | LT 101 SG T3 |
| | | | ABS | Ø12,7 (Snap Housing) | LT 101 S22 5* | LT 101 S22 15* | - | - |
| Receiver | | +/- 9° | Polycarbonate | Ø10 | LR 101 AP25 5 | LR 101 AP25 15 | LR 101 AP25 T3 | - |
| | | | | M12 x 1 | LR 101 TP25 5 | LR 101 TP25 15 | LR 101 TP25 T3 | - |
| | | | Nickel Plated Brass | | LR 101 TB25 5 | LR 101 TB25 15 | LR 101 TB25 T3 | - |
| | | | Stainless Steel | | LR 101 TS25 5 | LR 101 TS25 15 | LR 101 TS25 T3 | - |
| | | | Polyester | | □ 9,5 x 11,5 | LR 101 SG 5* | LR 101 SG 15* | LR 101 SG T3 |
| | | | ABS | Ø12,7 (Snap Housing) | LR 101 S22 5* | LR 101 S22 15* | - | - |

| | | | | | | | | |
|--------------------|----------------------|-----------------------|-----------------------|----------------------|----------------------|-----------------------|-----------------------|----------------------|
| Transmitter | 100 | +/- 6° | Polycarbonate | Ø10 | LT 100 AP38 5 | LT 100 AP38 15 | LT 100 AP38 T3 | - |
| | | | | M12 x 1 | LT 100 TP38 5 | LT 100 TP38 15 | LT 100 TP38 T3 | - |
| | | | Nickel Plated Brass | | LT 100 TB38 5 | LT 100 TB38 15 | LT 100 TB38 T3 | LT 100 TB58 J |
| Stainless Steel | LT 100 TS38 5 | LT 100 TS38 15 | LT 100 TS38 T3 | LT 100 TS58 J | | | | |
| Receiver | | +/- 9° | Polycarbonate | Ø10 | LR 100 AP38 5 | LR 100 AP38 15 | LR 100 AP38 T3 | - |
| | | | | M12 x 1 | LR 100 TP38 5 | LR 100 TP38 15 | LR 100 TP38 T3 | - |
| | | | Nickel Plated Brass | | LR 100 TB38 5 | LR 100 TB38 15 | LR 100 TB38 T3 | LR 100 TB58 J |
| Stainless Steel | LR 100 TS38 5 | LR 100 TS38 15 | LR 100 TS38 T3 | LR 100 TS58 J | | | | |

| | | | | | | | | |
|--------------------|----------------------|-----------------------|-----------------------|----------------------|----------------------|-----------------------|-----------------------|----------------------|
| Transmitter | 110 | +/- 8° | Polycarbonate | Ø10 | LT 110 AP38 5 | LT 110 AP38 15 | LT 110 AP38 T3 | - |
| | | | | M12 x 1 | LT 110 TP38 5 | LT 110 TP38 15 | LT 110 TP38 T3 | - |
| | | | Nickel Plated Brass | | LT 110 TB38 5 | LT 110 TB38 15 | LT 110 TB38 T3 | LT 110 TB58 J |
| Stainless Steel | LT 110 TS38 5 | LT 110 TS38 15 | LT 110 TS38 T3 | LT 110 TS58 J | | | | |
| Receiver | | +/- 3° | Polycarbonate | Ø10 | LR 110 AP38 5 | LR 110 AP38 15 | LR 110 AP38 T3 | - |
| | | | | M12 x 1 | LR 110 TP38 5 | LR 110 TP38 15 | LR 110 TP38 T3 | - |
| | | | Nickel Plated Brass | | LR 110 TB38 5 | LR 110 TB38 15 | LR 110 TB38 T3 | LR 110 TB58 J |
| Stainless Steel | LR 110 TS38 5 | LR 110 TS38 15 | LR 110 TS38 T3 | LR 110 TS58 J | | | | |

| | | | | | | | | |
|--------------------|------------|----------|---------------------|---------|----------------------|-----------------------|---|---|
| Transmitter | 120 | +/- 4° | Nickel Plated Brass | M18 x 1 | LT 120 TB45 5 | LT 120 TB45 15 | - | - |
| Receiver | | +/- 2,5° | | | LR 120 TB45 5 | LR 120 TB45 15 | - | - |

Note: If the applicable amplifier has sensor LED-drive, add 'L' after the series number for sensor monitor LED eg. LT/LR 101L AP25 5.
Sensors marked * do not have this optional feature.
Photo amplifiers to be ordered separately.

Remote Sensor Series

Applicable Photoelectric Amplifiers and Ranges

| Series | Operation Modes | Photoelectric Amplifiers | | | | | | | | | |
|--------|-------------------|--------------------------|-------|-------|-------|-------|--------|--------|-------|--------|-------|
| | | PA 01 | PA 09 | PA 10 | | PA 11 | MPA 21 | MPA 41 | | MPA 81 | |
| | | | | A | B | | | A/B | C/D | A/B | C/D |
| 101 | Thru-beam | 8 m | 5 m | 11 m | - | - | - | - | - | - | - |
| | Diffuse Proximity | 65 cm | 45 cm | 90 cm | - | - | - | - | - | - | - |
| 100 | Thru-beam | 10 m | - | - | 15 m | 18 m | 10 m | 8 m | 4 m | 8 m | 4 m |
| | Diffuse Proximity | 75 cm | - | - | 1,1 m | 1,1 m | 75 cm | 65 cm | 35 cm | 65 cm | 35 cm |
| 110 | Thru-beam | 23 m | - | - | 35 m | 40 m | 25 m | 18 m | 9 m | 18 m | 9 m |
| | Diffuse Proximity | 1,6 m | - | - | 2 m | 2 m | 1,6 m | 1,3 m | 70 cm | 1,3 m | 70 cm |
| 120 | Thru-beam | 45 m | - | - | 60 m | 70 m | 45 m | 35 m | 18 m | 35 m | 18 m |
| | Diffuse Proximity | 3,5 m | - | - | 4 m | 5 m | 3,5 m | 3 m | 2 m | 3 m | 2 m |

Note: For ranges using fibre optics, please refer to page 45.

Connections

| | Cable | M8 Plug/Cable | M12 Plug/Cable |
|--------------------|--------|---------------|----------------|
| Transmitter Signal | Red | Pin 1/Brown | Pin 1/Brown |
| Transmitter Ground | Black | Pin 3/Blue | Pin 3/Blue |
| Receiver Signal | Yellow | Pin 4/Black | Pin 4/Black |
| Receiver Ground | Shield | Pin 3/Blue | Pin 3/Blue |

3 pin, M8

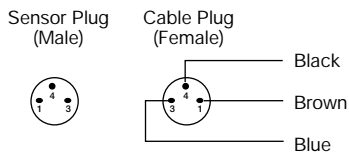

4 pin, M12

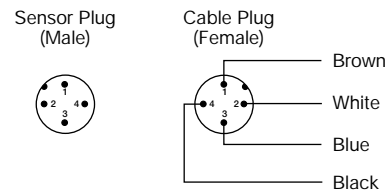

Dimensions and Descriptions

Series 101

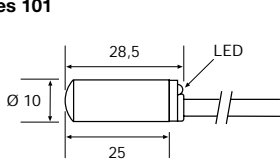

AP25 5/15

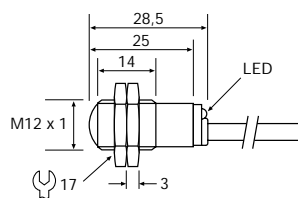

TP/TB/TS25 5/15

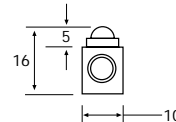

SG 5/15

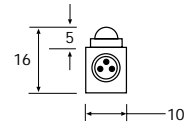

SG T3

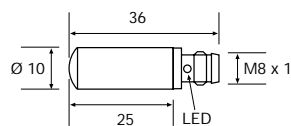

AP25 T3

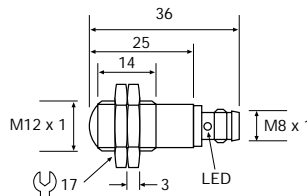

TP/TB/TS25 T3

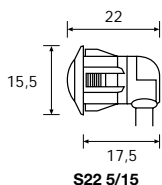
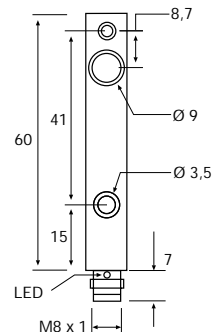
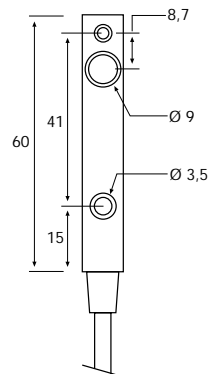

S22 5/15

(Units in mm)

Dimensions and Descriptions

Series 100/110

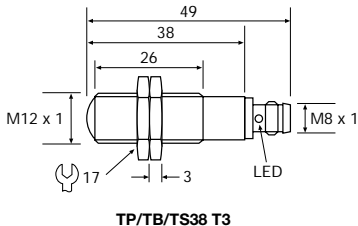
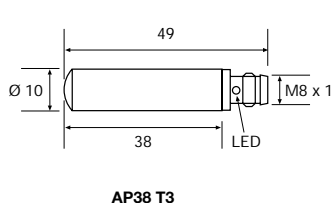
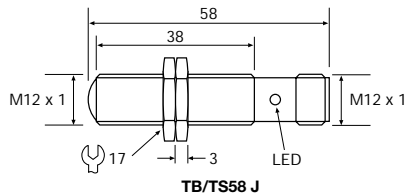
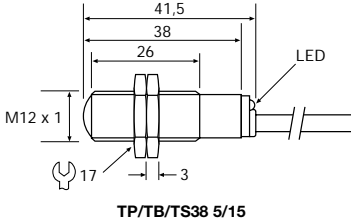
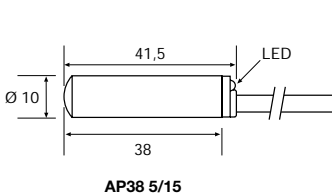

(Units in mm)

Series 120

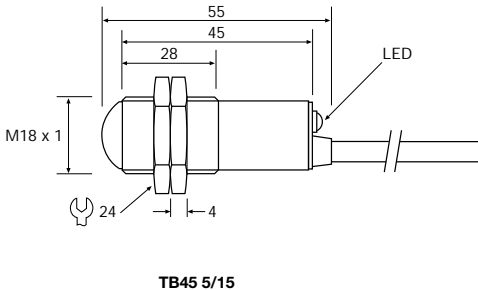

(Units in mm)

Telco reserves the right to change specifications without notice.

Description

- Operation mode and max sensing range:
Thru beam: 0-45 m
Diffuse proximity: 0-3,5 m
- 230 V ac, 115 V ac or 24 V ac/dc supply voltage
- Automatic and/or manual sensitivity adjustment
- Sensor LED-drive
- Adjustable on/off time delay
- 1 relay or 1 transistor output
- STF (Patented)
- Switch selectable light or dark function
- Switch selectable long or short range
- Power, output and signal status indicators
- Test input
- 11-pole DIN socket connection



The PA 01 is to be used in conjunction with a set of remote transmitter LT and receiver LR from the series 101, 100, 110 or 120.

This amplifier series offers a choice between automatic and/or manual sensitivity adjustment with or without a 0-10 sec on/off time delay via integral potentiometers located on the front panel of the amplifier. Output can be selected from either a relay or an NPN/PNP transistor output. Light or dark function and long or short range is switch selectable.

In automatic mode, set up is required. This is achieved by pressing the teach-in button located on the front panel. This unique feature ensures that the transmitting power level is adjusted according to the

application, thus achieving optimal hysteresis and excess gain. Once set up, the system will automatically compensate for moderate misalignment and contamination during operation. In manual mode, the teach-in button allows for an overall manual system test by temporarily disabling the transmitter. The sensor LED drive powers the optional monitor LEDs available on the remote sensors – output (LT) and power (LR).

The patented feature STF allows up to 3 identical systems to operate within a close distance of each other without optical cross talk as each system automatically maintains different transmitter frequencies.

Technical Data

| | | |
|----------------------------------|------------|--|
| Supply voltage | | 115 V ac, 230 V ac (+/- 15%) 12-30 V ac or 12-36 V dc |
| Power consumption | | Max. 2,5 VA |
| Output | Relay | 1 open / 1 close, 230 V ac / 3 A, 120 V ac / 5 A |
| | Transistor | 100 mA / 36 V dc |
| Power on indicator | | Green LED |
| Output indicator | | Yellow LED |
| Signal status indicator | | Green LED |
| LR sensor failure indicator | | - |
| LT sensor failure indicator | | - |
| Sensor monitor LED drive | | The green monitor LED on the receiver indicates 'Power ON' The yellow monitor LED on the transmitter indicates 'PA 01 output activated' |
| Hysteresis | | Approx. 20 % |
| Operation frequency | | 12 Hz |
| Response time t_{ON} / t_{OFF} | | 40 ms / 40 ms |
| Delay t_{ON} / t_{OFF} | PA 01 C | 0 - 10 sec |
| Housing material | | Noryl |

Environmental Data

| | | |
|------------------------|--|----------------|
| Temperature, operation | | - 10 to +55 °C |
| Temperature, storage | | - 40 to +80 °C |
| Sealing class | | IP 40 |
| Approvals | | CE |

Available Types

| Model | Connection | Supply Voltage | 12 – 30 V ac | 115 V ac | 230 V ac |
|--|--------------------|----------------|--------------------|--------------------|--------------------|
| | | Output | Order Reference | | |
| PA 01 A Automatic | 11-pole DIN socket | Relay | PA 01 A 519 | PA 01 A 511 | PA 01 A 510 |
| | | NPN and PNP | PA 01 A 619 | PA 01 A 611 | PA 01 A 610 |
| PA 01 B Automatic/Manual | | Relay | PA 01 B 519 | PA 01 B 511 | PA 01 B 510 |
| | | NPN and PNP | PA 01 B 619 | PA 01 B 611 | PA 01 B 610 |
| PA 01 C Automatic/Manual on/off delay | | Relay | PA 01 C 519 | PA 01 C 511 | PA 01 C 510 |
| | | NPN and PNP | PA 01 C 619 | PA 01 C 611 | PA 01 C 610 |

Note: Remote sensors and 11-pole DIN socket to be ordered separately.

Applicable Remote Sensors and Ranges

| Series | Thru Beam | Diffuse Proximity |
|------------|-----------|-------------------|
| 101 | 8 m | 65 cm |
| 100 | 10 m | 75 cm |
| 110 | 23 m | 2 m |
| 120 | 45 m | 3,5 m |

Wiring Diagrams

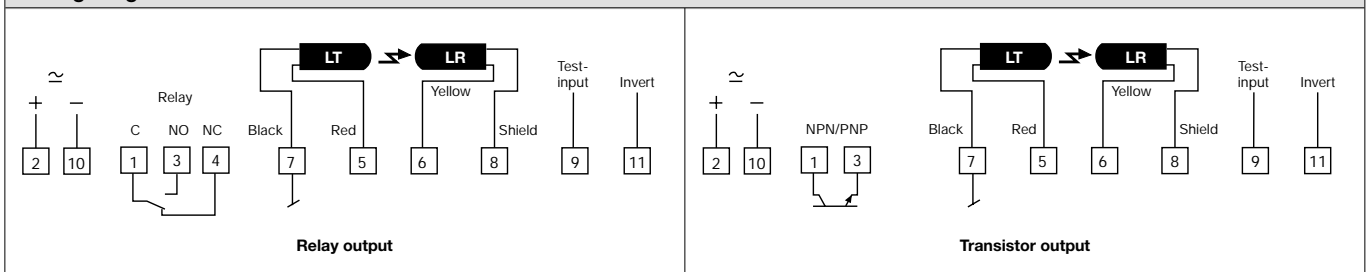

Dimensions and Descriptions

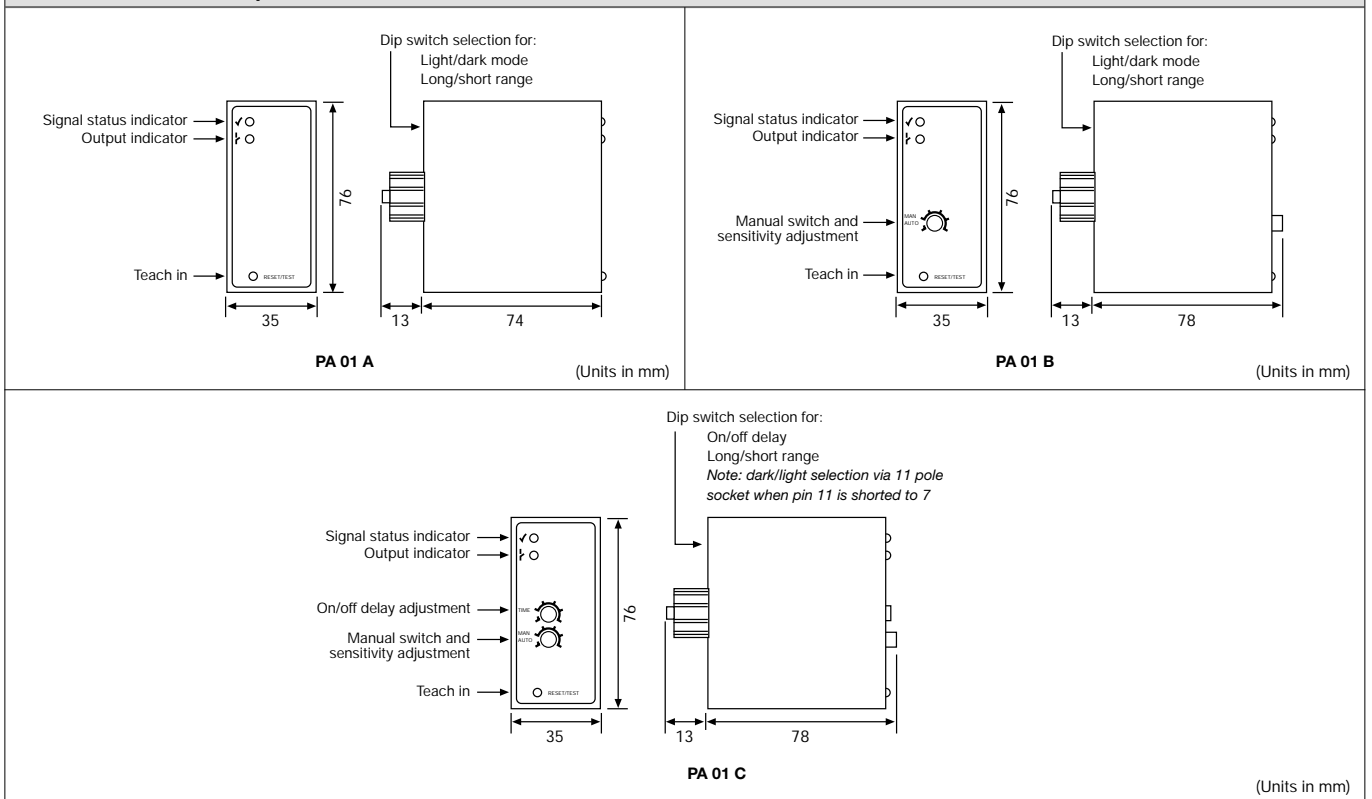

Telco reserves the right to change specifications without notice.

Description

- Operation mode and max sensing range:
Thru beam: 5 m
Diffuse proximity: 45 cm
- 12 or 24 V dc supply voltage
- 1 relay output acc. to UNI 8612
- Power and output indicators
- Screw terminals connection

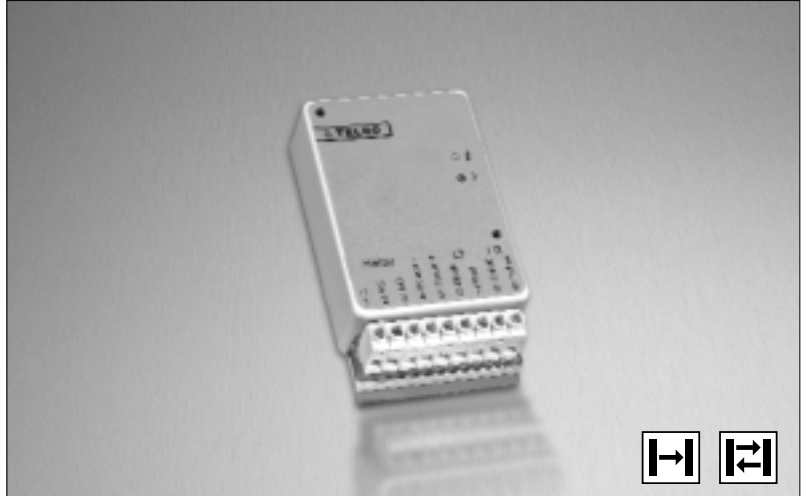

The PA 09 is to be used in conjunction with a set of remote transmitter LT and receiver LR from the series 101.

This amplifier series is low cost, designed especially for the elevator and door industries, offering a relay output, designed according to the UNI 8612 standard whereby 2 relays are mounted in series.

| Technical Data | |
|----------------------------------|--------------------|
| Supply voltage | 12 V dc or 24 V dc |
| Voltage tolerance @ 12 V dc | -10 / +20 % |
| Voltage tolerance @ 24 V dc | -15 / +20 % |
| Power consumption | Max. 2 VA |
| Output relay | 24 V dc / 2A |
| Power on indicator | Green LED |
| Output indicator | Yellow LED |
| Signal status indicator | - |
| LR sensor failure indicator | - |
| LT sensor failure indicator | - |
| Sensor monitor LED drive | - |
| Hysteresis | Approx. 30 % |
| Operation frequency | 10 Hz |
| Response time t_{ON} / t_{OFF} | 50 ms / 50 ms |
| Delay t_{ON} / t_{OFF} | - |
| Housing material | Polystyrene |

| Environmental Data | |
|------------------------|----------------|
| Temperature, operation | - 10 to +50 °C |
| Temperature, storage | - 40 to +80 °C |
| Sealing class | IP 40 |
| Approvals | CE |

Available Types

| | | | | |
|----------------|-----------------|----------------|--------------------|--------------------|
| Model | Connection | Supply Voltage | 12 V dc | 24 V dc |
| | | Output | Order Reference | |
| PA 09 B | Screw terminals | Relay | PA 09 B 504 | PA 09 B 503 |

Note: Remote sensors to be ordered separately.

Applicable Remote Sensors and Ranges

| | | |
|------------|------------------|--------------------------|
| Series | Thru Beam | Diffuse Proximity |
| 101 | 5 m | 45 cm |

Wiring Diagrams

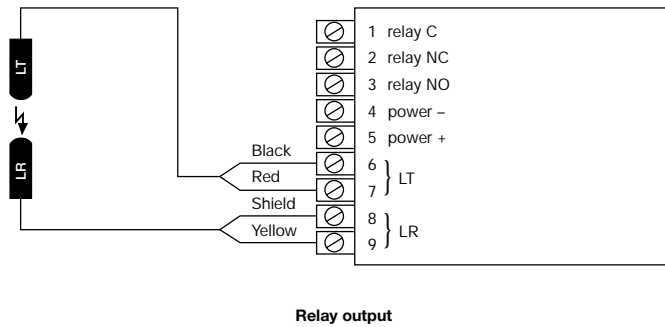

Dimensions and Descriptions

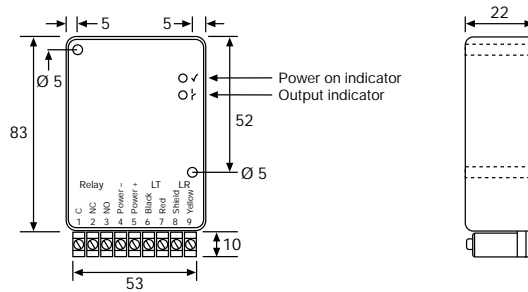

PA 09 B

(Units in mm)

Telco reserves the right to change specifications without notice.

Description

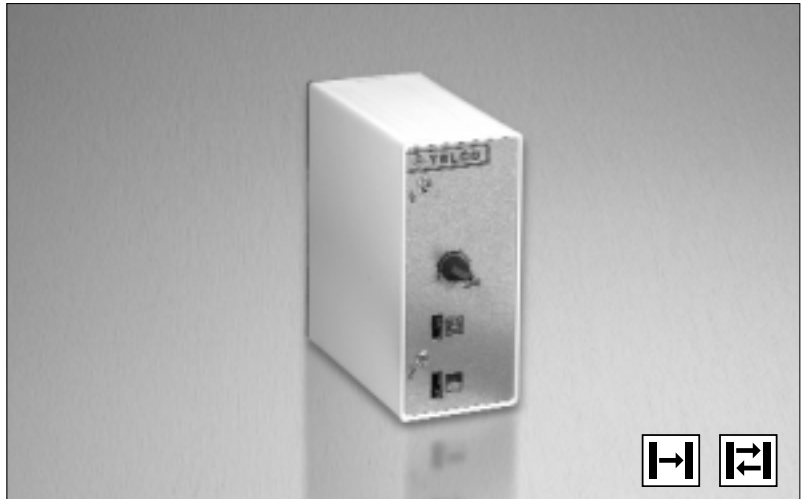

- Operation mode and max sensing range:
Thru beam: 0-60 m
Diffuse proximity: 0-4 m
- 230 V ac, 115 V ac, 24 V ac or 24 V dc supply voltage
- Manual sensitivity adjustment
- 1 relay or 1 transistor output
- Switch selectable light or dark function
- Switch selectable long or short range
- Power and output indicators
- 11-pole DIN socket connection



The PA 10 A is to be used in conjunction with a remote transmitter LT and receiver LR from series 101, whilst the PA 10 B is intended for use with series 100, 110, and 120.

This amplifier series offers manual sensitivity adjustment via an integral potentiometer located on the front panel of the amplifier. Output can be selected from either a relay or an NPN/PNP transistor output. Light or dark function and long or short range are switch selectable.

| Technical Data | |
|------------------------------------|--|
| Supply voltage | 24 V dc, 24 V ac, 115 V ac or 230 V ac |
| Voltage tolerance | +/- 15 % |
| Power consumption | Max. 3,2 VA |
| Output | Relay Transistor |
| | 1 open / 1 close, 250 V ac / 3 A, 120 V ac / 5 A |
| | 40 mA / 30 V dc |
| Power on indicator | Green LED |
| Output indicator | Red LED |
| Signal level indicator | - |
| LR sensor failure indicator | - |
| LT sensor failure indicator | - |
| Sensor monitor LED drive | - |
| Hysteresis | Approx. 40 % |
| Operation frequency | 10 Hz |
| Response time t_{ON} / t_{OFF} | 40 ms / 40 ms |
| Delay t_{ON} / t_{OFF} | - |
| Housing material | Noryl |

| Environmental Data | |
|------------------------|--|
| Temperature, operation | - 10 to +50 °C |
| Temperature, storage | - 40 to +80 °C |
| Sealing class | IP 40 |
| Approvals | CE   |

Available Types

| Model | Connection | Supply Voltage | 24 V dc | 24 V ac | 115 V ac | 230 V ac |
|----------------|--------------------|----------------|--------------------|--------------------|--------------------|--------------------|
| | | Output | Order Reference | | | |
| PA 10 A | 11-pole DIN socket | Relay | PA 10 A 513 | PA 10 A 512 | PA 10 A 511 | PA 10 A 510 |
| | | NPN and PNP | PA 10 A 613 | PA 10 A 612 | PA 10 A 611 | PA 10 A 610 |
| PA 10 B | | Relay | PA 10 B 513 | PA 10 B 512 | PA 10 B 511 | PA 10 B 510 |
| | | NPN and PNP | PA 10 B 613 | PA 10 B 612 | PA 10 B 611 | PA 10 B 610 |

Note: Remote sensors and 11-pole DIN socket to be ordered separately.

Applicable Remote Sensors and Ranges

| Series | Thru Beam | Diffuse Proximity |
|---------------------------|-----------|-------------------|
| 101 (only PA 10 A) | 11 m | 90 cm |
| 100 (only PA 10 B) | 15 m | 1,1 m |
| 110 (only PA 10 B) | 35 m | 2 m |
| 120 (only PA 10 B) | 60 m | 4 m |

Wiring Diagrams

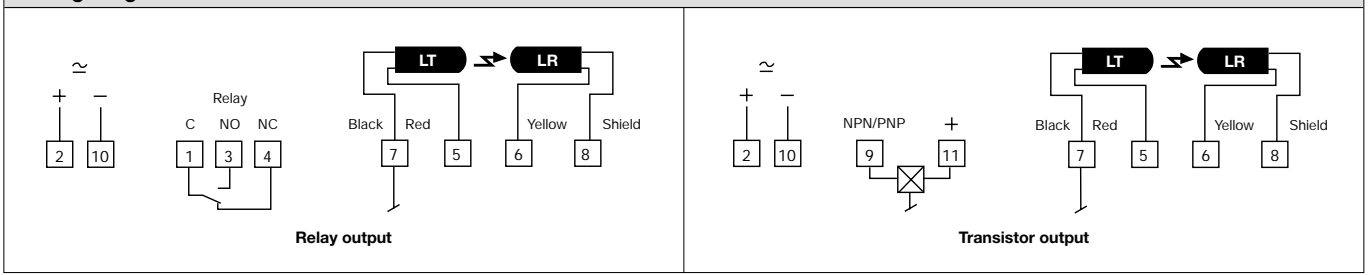

Dimensions and Descriptions

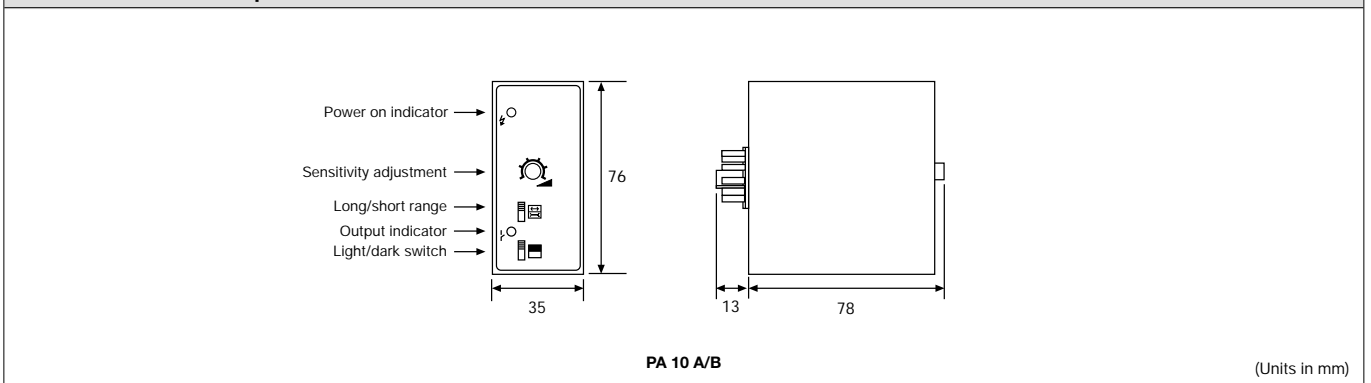

Telco reserves the right to change specifications without notice.

Description

- Operation mode and max sensing range:
 - Thru beam:** 0-70 m
 - Diffuse proximity:** 0-5 m
- 230 V ac, 115 V ac, 24 V ac or 24 V dc supply voltage
- Manual sensitivity adjustment
- Sensor LED-drive
- Automatic sensor test
- Adjustable on/off time delay
- 1 relay and/or 1 transistor output
- Switch selectable light or dark function
- Switch selectable long or short range
- Power, output and signal level indicators
- 11-pole DIN socket connection

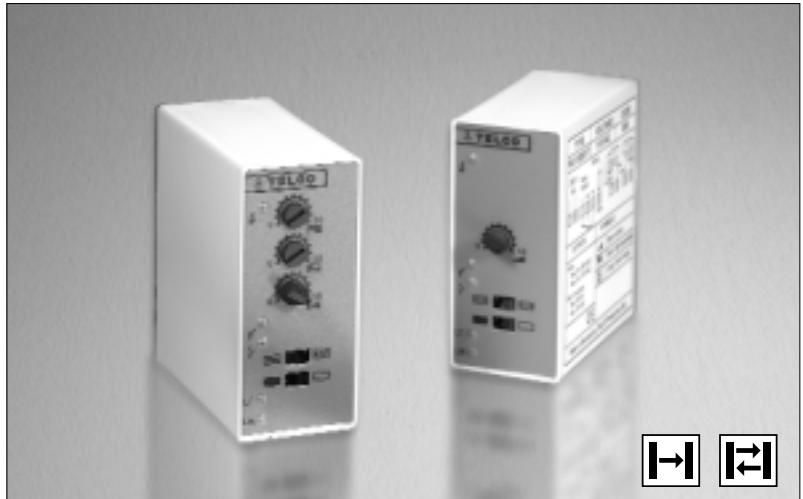

The PA 11 is to be used in conjunction with a set of remote transmitter LT and receiver LR from the series 100, 110 and 120.

This amplifier series offers manual sensitivity adjustment via integral potentiometers located on the front panel of the amplifier. Output can be selected from either a relay and NPN or NPN and PNP transistor outputs with or without a 0-10 sec on/off time delay. Light or dark function and long or short range is switch selectable.

The microprocessor controlled sensor test ensures that the system will automatically detect and indicate a faulty transmitter or receiver – cable break or electrical failure – during operation, through the relevant LED located on the front panel. The sensor LED drive powers the optional monitor LEDs available on the remote sensors – output (LT) and power (LR).

| Technical Data | |
|----------------------------------|--|
| Supply voltage | 24 V dc, 24 V ac, 115 V ac or 230 V ac |
| Voltage tolerance | +/- 15 % |
| Power consumption | Max. 3,5 VA |
| Output | Relay Transistor |
| | 1 open / 1 close, 250 V ac / 3 A, 120 V ac / 5 A |
| | 60 mA / 30 V dc |
| Power on indicator | Green LED |
| Output indicator | Yellow LED |
| Signal level indicator | Green LED |
| LR sensor failure indicator | Red LED |
| LT sensor failure indicator | Red LED |
| Sensor monitor LED drive | The green monitor LED on the receiver indicates 'Power ON' The yellow monitor LED on the transmitter indicates 'PA 11 output activated' |
| Hysteresis | Approx. 45 % |
| Operation frequency | 20 Hz |
| Response time t_{ON} / t_{OFF} | 35 ms / 35 ms |
| Delay t_{ON} / t_{OFF} | PA 11 A Adjustable 0 – 10 sec |
| Housing material | Noryl |

| Environmental Data | |
|------------------------|---------------|
| Temperature, operation | -10 to +50 °C |
| Temperature, storage | -40 to +80 °C |
| Sealing class | IP 40 |
| Approvals | CE |

Available Types

| Model | Connection | Supply Voltage | 24 V dc | 24 V ac | 115 V ac | 230 V ac |
|--------------------------------|--------------------|----------------|---------------------|---------------------|---------------------|---------------------|
| | | Output | Order Reference | | | |
| PA 11 A On/Off delay | 11-pole DIN socket | Relay and NPN | PA 11 A 303T | PA 11 A 302T | PA 11 A 301T | PA 11 A 300T |
| | | NPN and PNP | PA 11 A 403T | PA 11 A 402T | PA 11 A 401T | PA 11 A 400T |
| PA 11 B | | Relay and NPN | PA 11 B 303T | PA 11 B 302T | PA 11 B 301T | PA 11 B 300T |
| | | NPN and PNP | PA 11 B 403T | PA 11 B 402T | PA 11 B 401T | PA 11 B 400T |

Note: Remote sensors and 11-pole DIN socket to be ordered separately.

Applicable Remote Sensors and Ranges

| Series | Thru Beam | Diffuse Proximity |
|------------|-----------|-------------------|
| 100 | 18 m | 1,1 m |
| 110 | 40 m | 2 m |
| 120 | 70 m | 5 m |

Wiring Diagrams

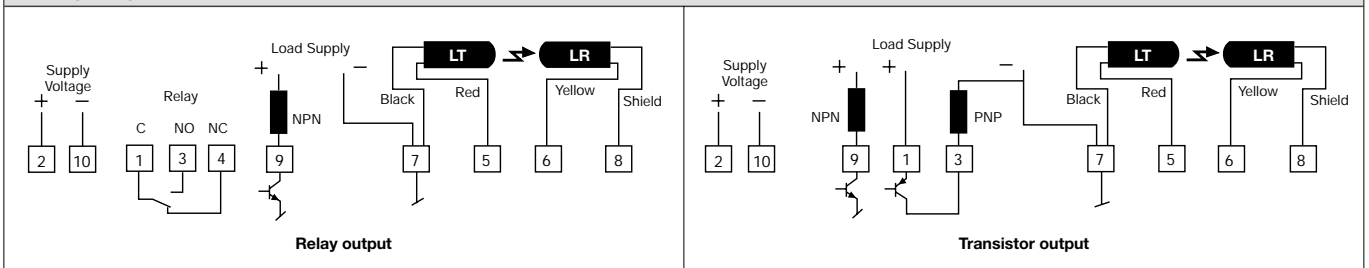

Dimensions and Descriptions

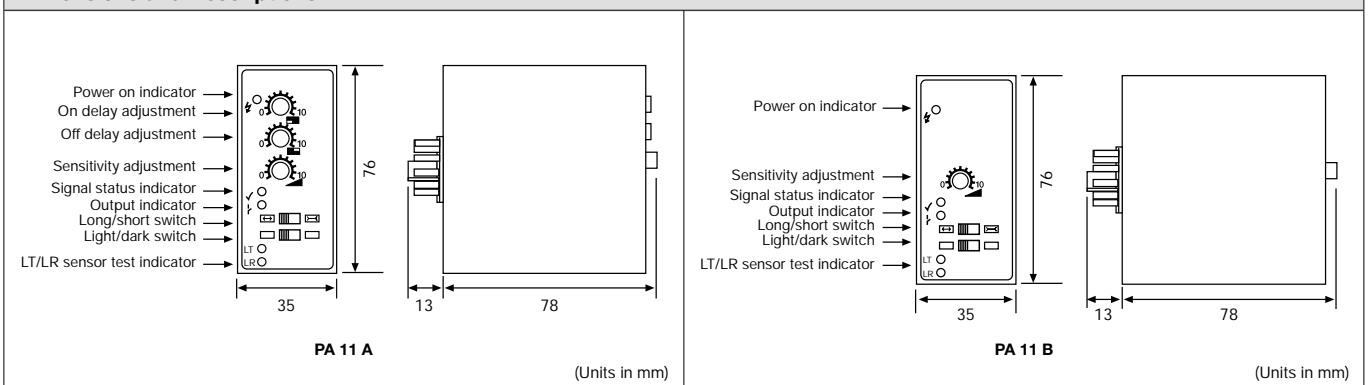

Telco reserves the right to change specifications without notice.

Description

- Operation mode and max sensing range:
Thru beam: 0-45 m
Diffuse proximity: 0-3,5 m
- 230 V ac, 115 V ac, 24 V ac or 24 V dc supply voltage
- Manual sensitivity adjustment
- Adjustable on/off time delay
- 2 relays or 2 transistor outputs
- Power, output and signal level indicators
- Switch selectable light or dark function
- Switch selectable long or short range
- 11-pole DIN socket connection

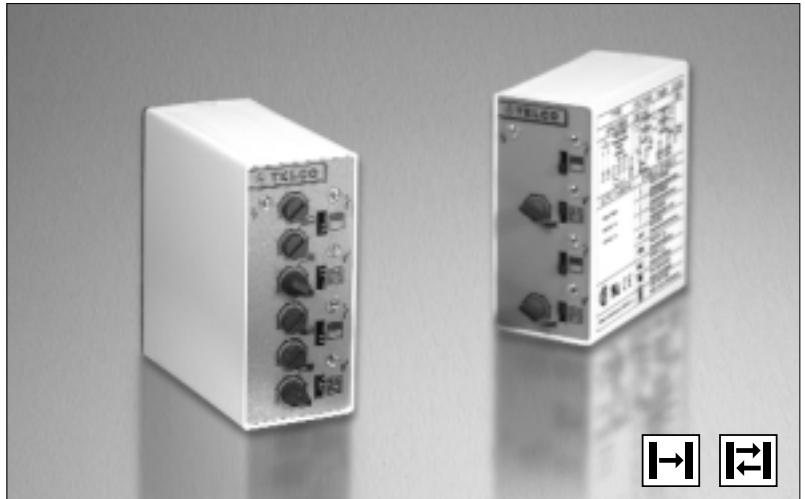

The MPA 21 is to be used in conjunction with 2 sets of remote transmitters LT and receivers LR, from the series 100, 110 and 120.

The 2 channels operate independently of each other with their own set of remote transmitter and receiver. The multiplexing function ensures that optical cross talk between channels is prevented.

The series offers a choice between 2 individual relays or 2 individual

NPN/PNP transistor outputs, with or without an adjustable 0-3 sec on/off time delay.

This amplifier series offers manual sensitivity adjustment for each individual channel via integral potentiometers located on the front panel of the amplifier. Light or dark function and long or short range is switch selectable for each individual channel.

| Technical Data | |
|--|--|
| Supply voltage | 24 V dc, 24 V ac, 115 V ac or 230 V ac |
| Voltage tolerance | +/- 15 % |
| Power consumption | Max. 3 VA |
| Output | Relay Transistor |
| | 1 open / 1 close, 250 V ac / 3 A, 120 V ac / 5 A |
| | 40 mA / 30 V dc |
| Power on indicator | Green LED |
| Output indicator | Red LED |
| Signal level indicator | Green LED |
| LR sensor failure indicator | - |
| LT sensor failure indicator | - |
| Sensor monitor LED drive | - |
| Hysteresis | Approx. 35 % |
| Operation frequency | MPA 21 A MPA 21 B |
| | 9 Hz 11 Hz |
| Response time t _{ON} / t _{OFF} | MPA 21 A MPA 21 B |
| | 55 ms / 55 ms 45 ms / 45 ms |
| Delay t _{ON} / t _{OFF} | MPA 21 A |
| | 0 - 3 sec |
| Housing material | Noryl |

| Environmental Data | |
|------------------------|----------------|
| Temperature, operation | - 10 to +50 °C |
| Temperature, storage | - 40 to +80 °C |
| Sealing class | IP 40 |
| Approvals | CE |

Available Types

| Model | Connection | Supply Voltage | 24 V dc | 24 V ac | 115 V ac | 230 V ac |
|---------------------------------|--------------------|----------------------|---------------------|---------------------|---------------------|---------------------|
| | | Output | Order Reference | | | |
| MPA 21 A On/Off delay | 11-pole DIN socket | 2 individual relays | MPA 21 A 503 | MPA 21 A 502 | MPA 21 A 501 | MPA 21 A 500 |
| | | 2 individual NPN/PNP | MPA 21 A 603 | MPA 21 A 602 | MPA 21 A 601 | MPA 21 A 600 |
| MPA 21 B | | 2 individual relays | MPA 21 B 503 | MPA 21 B 502 | MPA 21 B 501 | MPA 21 B 500 |
| | | 2 individual NPN/PNP | MPA 21 B 603 | MPA 21 B 602 | MPA 21 B 601 | MPA 21 B 600 |

Note: Remote sensors and 11-pole DIN socket to be ordered separately.

Applicable Remote Sensors and Ranges

| Series | Thru Beam | Diffuse Proximity |
|------------|-----------|-------------------|
| 100 | 10 m | 75 cm |
| 110 | 25 m | 1,6 m |
| 120 | 45 m | 3,5 m |

Wiring Diagrams

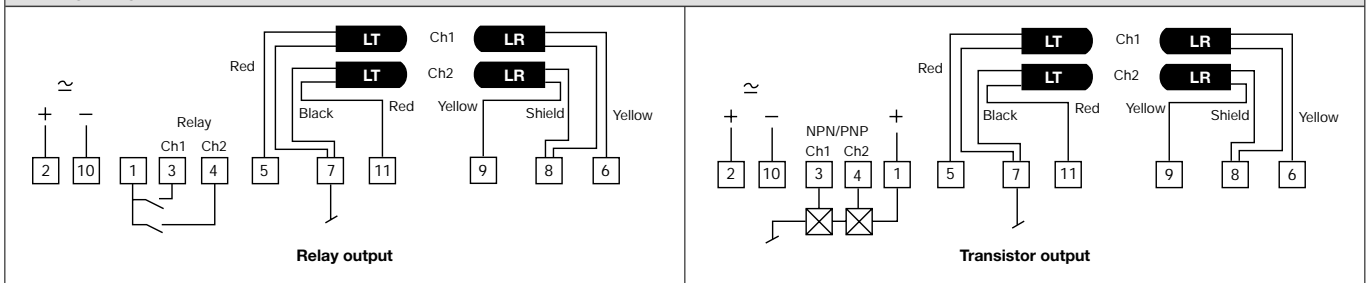

Dimensions and Descriptions

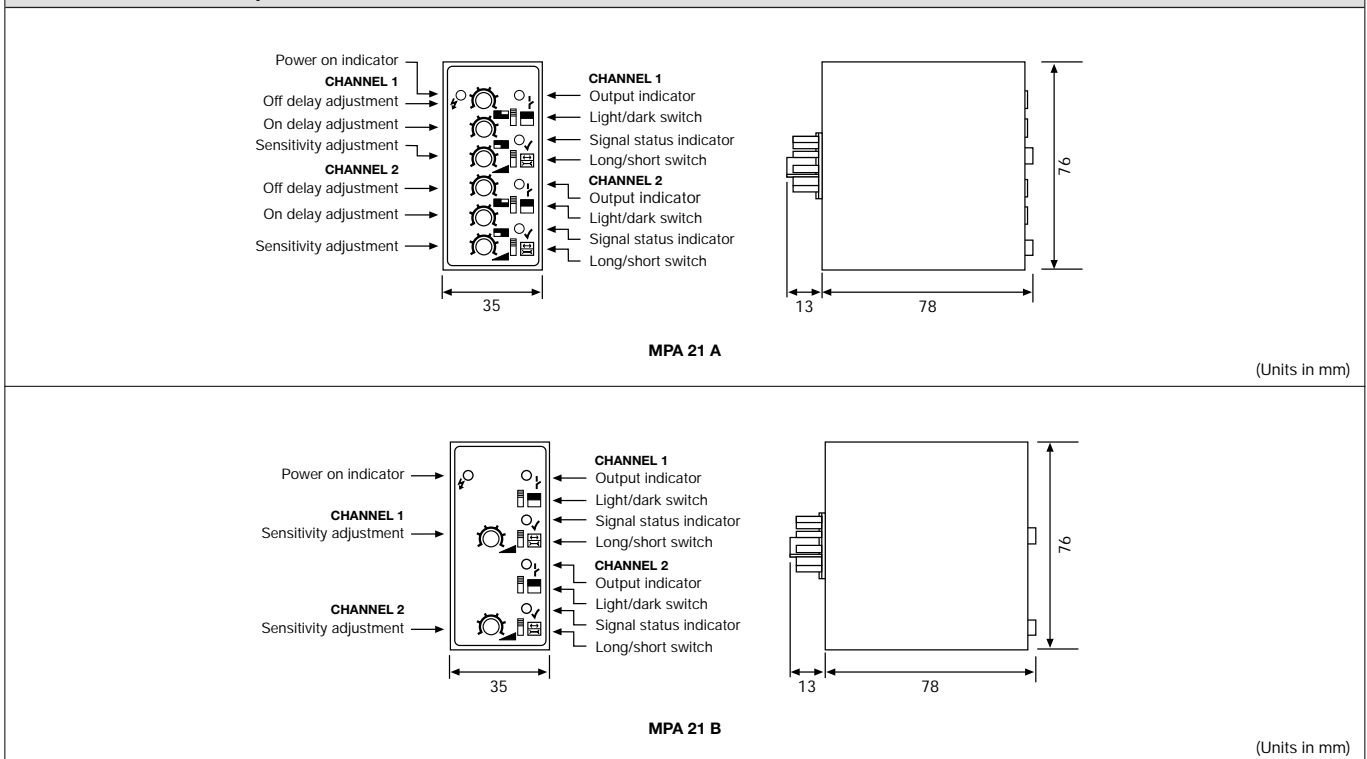

Telco reserves the right to change specifications without notice.

Description

- Operation mode and max sensing range:
Thru beam: 0-35 m
Diffuse proximity: 0-3 m
- 230 V ac, 115 V ac, 24 V ac or 24 V dc supply voltage
- Manual sensitivity adjustment
- Adjustable on/off time delay
- 4 relays and/or 4 transistor individual outputs
- 1 relay and 1 transistor common output
- Switch selectable light or dark function
- Switch selectable long or short range
- Power, output and signal level indicators
- Screw terminals connection

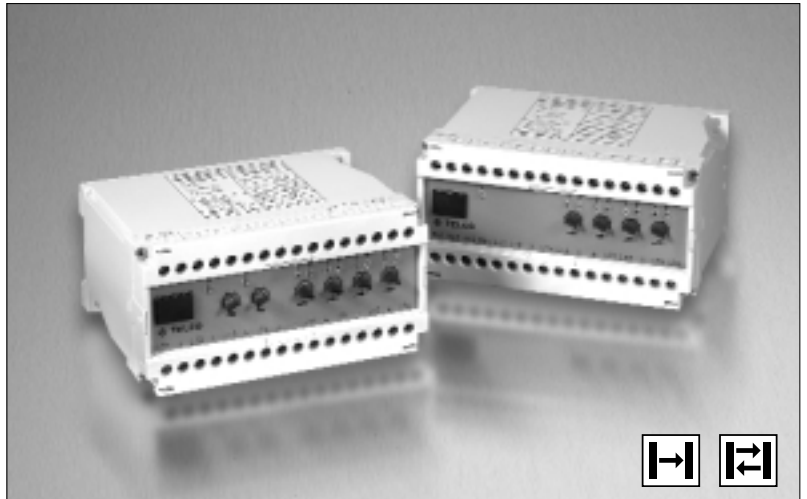

The MPA 41 is to be used in conjunction with 4 sets of remote transmitters LT and receivers LR, from the series 100, 110 and 120.

The 4 channels operate independently of each other with their own set of remote transmitter and receiver. The multiplexing function ensures that optical cross talk between channels is prevented. The series offers a choice between 4 individual relays and/or 4 individual NPN/PNP



transistor outputs, or 1 common relay and 1 common transistor output which features an adjustable 0-10 sec on/off time delay.

This amplifier series offers manual sensitivity adjustment for each individual channel via integral potentiometers located on the front panel of the amplifier. Light or dark function and long or short range is switch selectable for each individual channel.

Technical Data

| | | |
|----------------------------------|--------------|--|
| Supply voltage | | 24 V dc, 24 V ac, 115 V ac or 230 V ac |
| Voltage tolerance | | +/- 15 % |
| Power consumption | | Max. 6,5 VA |
| Output | Relay | 1 open / 1 close, 250 V ac / 3 A, 120 V ac / 5 A |
| | Transistor | 40 mA / 30 V dc |
| Power on indicator | | Green LED |
| Output indicator | | Red LED |
| Signal level indicator | | Green LED |
| LR sensor failure indicator | | - |
| LT sensor failure indicator | | - |
| Sensor monitor LED drive | | - |
| Hysteresis | | Approx. 35 % |
| Operation frequency | MPA 41 A / B | 10 Hz |
| | MPA 41 C / D | 25 Hz |
| Response time t_{ON} / t_{OFF} | MPA 41 A / B | 50 ms / 50 ms |
| | MPA 41 C / D | 20 ms / 20 ms |
| Delay t_{ON} / t_{OFF} | MPA 41 B / D | 0 - 10 sec |
| Housing material | | Noryl |

Environmental Data

| | |
|------------------------|--|
| Temperature, operation | - 10 to +50 °C |
| Temperature, storage | - 40 to +80 °C |
| Sealing class | IP 30 |
| Approvals | CE   |

Available Types

| Model | Connection | Supply Voltage | 24 V dc | 24 V ac | 115 V ac | 230 V ac |
|-----------------------|-----------------|--|---------------------|---------------------|---------------------|---------------------|
| | | Output | Order Reference | | | |
| MPA 41 A | Screw terminals | 4 individual NPN/PNP | MPA 41 A 603 | MPA 41 A 602 | MPA 41 A 601 | MPA 41 A 600 |
| | | 4 individual relays and 4 individual NPN/PNP | MPA 41 A 703 | MPA 41 A 702 | MPA 41 A 701 | MPA 41 A 700 |
| MPA 41 B On/Off delay | | 1 common relay and 1 common NPN/PNP | MPA 41 B 703 | MPA 41 B 702 | MPA 41 B 701 | MPA 41 B 700 |
| MPA 41 C | | 4 individual NPN/PNP | MPA 41 C 603 | MPA 41 C 602 | MPA 41 C 601 | MPA 41 C 600 |
| | | 4 individual relays and 4 individual NPN/PNP | MPA 41 C 703 | MPA 41 C 702 | MPA 41 C 701 | MPA 41 C 700 |
| MPA 41 D On/Off delay | | 1 common relay and 1 common NPN/PNP | MPA 41 D 703 | MPA 41 D 702 | MPA 41 D 701 | MPA 41 D 700 |

Note: Remote sensors to be ordered separately.

Applicable Remote Sensors and Ranges

| Series | Thru Beam | Diffuse Proximity |
|-------------------|-----------|-------------------|
| MPA 41 A/B | | |
| 100 | 8 m | 65 cm |
| 110 | 18 m | 1,3 m |
| 120 | 35 m | 3 m |
| MPA 41 C/D | | |
| 100 | 4 m | 35 cm |
| 110 | 9 m | 70 cm |
| 120 | 18 m | 2 m |

Wiring Diagrams

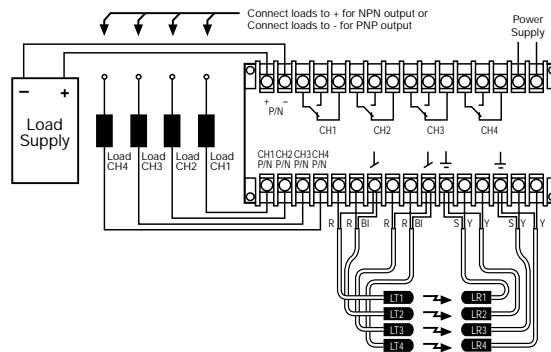

| Wire Code | |
|-----------|--------|
| R | Red |
| Bl | Black |
| Y | Yellow |
| S | Shield |

MPA 41 A/C

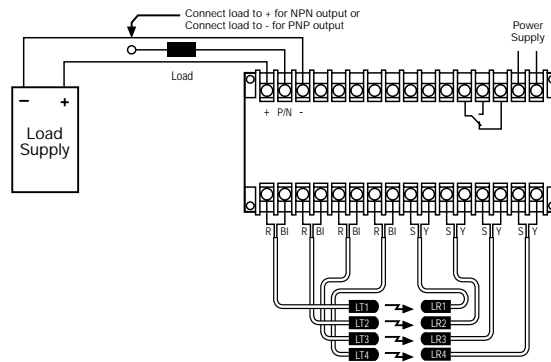

| Wire Code | |
|-----------|--------|
| R | Red |
| Bl | Black |
| Y | Yellow |
| S | Shield |

MPA 41 B/D

Dimensions and Descriptions

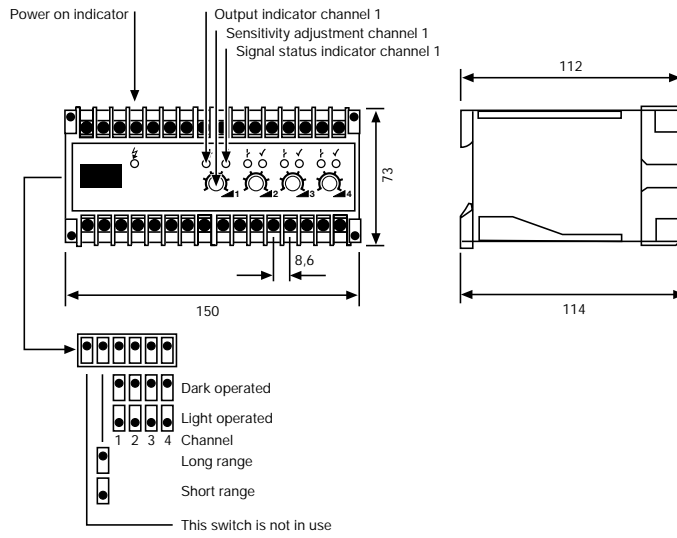

MPA 41 A/C

(Units in mm)

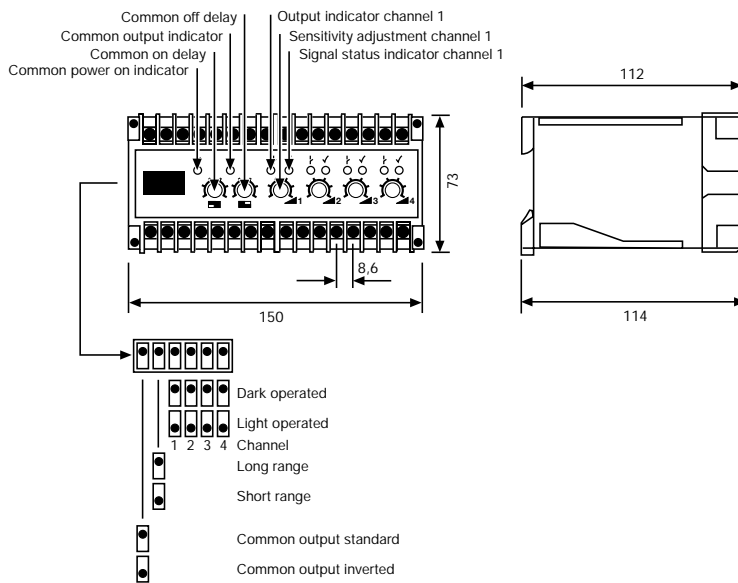

MPA 41 B/D

(Units in mm)

Telco reserves the right to change specifications without notice.

Description

- Operation mode and max sensing range:
Thru beam: 0-35 m
Diffuse proximity: 0-3 m
- 230 V ac, 115 V ac, 24 V ac or 24 V dc supply voltage
- Manual sensitivity adjustment
- Adjustable on/off time delay
- 8 relays or 8 transistor individual outputs
- 1 relay and 1 transistor common output
- Switch selectable light or dark function
- Switch selectable long or short range
- Power, output and signal level indicators
- Screw terminals connection

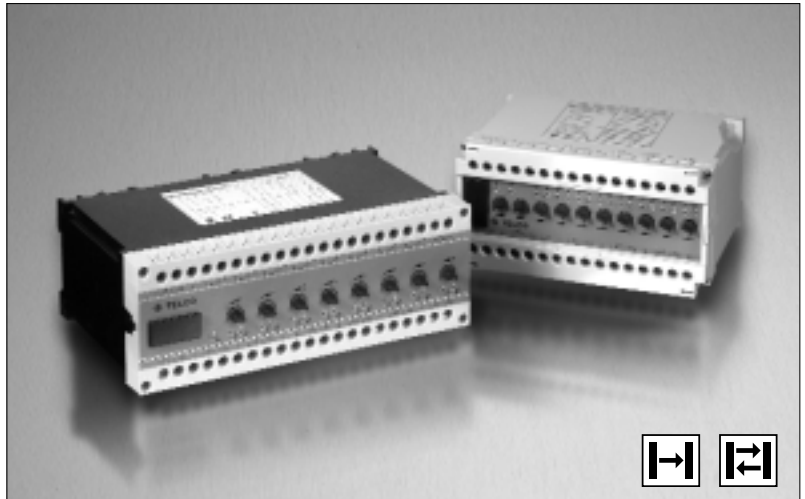



The MPA 81 is to be used in conjunction with 8 sets of remote transmitters LT and receivers LR, from the series 100, 110 and 120.

The 8 channels operate independently of each other with their own set of remote transmitter and receiver. The multiplexing function ensures that optical cross talk between channels is prevented. The series offers a choice between 8 individual relays or 8 individual NPN/PNP transistor

outputs, or 1 common relay and 1 common NPN/PNP transistor output which has an adjustable 0-10 sec on-off time delay.

This amplifier series offers manual sensitivity adjustment for each individual channel, via integral potentiometers located on the front panel of the amplifier. Light or dark function and long or short range is switch selectable for each individual channel.

| Technical Data | | |
|----------------------------------|-------------|--|
| Supply voltage | | 24 V dc, 24 V ac, 115 V ac or 230 V ac |
| Voltage tolerance | | +/- 15 % |
| Power consumption | | Max. 6,5 VA |
| Output | Relay | 1 open / 1 close, 250 V ac / 3 A, 120 V ac / 5 A |
| | Transistor | 40 mA / 30 V dc |
| Power on indicator | | Green LED |
| Output indicator | | Red LED |
| Signal level indicator | | Green LED |
| LR sensor failure indicator | | - |
| LT sensor failure indicator | | - |
| Sensor monitor LED drive | | - |
| Hysteresis | | Approx. 35 % |
| Operation frequency | MPA 81 A /B | 5 Hz |
| | MPA 81 C/D | 13 Hz |
| Response time t_{ON} / t_{OFF} | MPA 81 A/B | 90 ms / 90 ms |
| | MPA 81 C/D | 36 ms / 36 ms |
| Delay t_{ON} / t_{OFF} | MPA 81 B/D | 0 - 10 sec |
| Housing material | | Noryl |

| Environmental Data | | |
|------------------------|--|--|
| Temperature, operation | | - 10 to +50 °C |
| Temperature, storage | | - 40 to +80 °C |
| Sealing class | | IP 30 |
| Approvals | | CE   |

Available Types

| Model | Connection | Supply Voltage | 24 V dc | 24 V ac | 115 V ac | 230 V ac |
|--------------------------|-----------------|--|--|--------------|--------------|--------------|
| | | Output | Order Reference | | | |
| MPA 81 A | Screw terminals | 8 individual relays | MPA 81 A 503 | MPA 81 A 502 | MPA 81 A 501 | MPA 81 A 500 |
| | | 8 individual NPN/PNP | MPA 81 A 603 | MPA 81 A 602 | MPA 81 A 601 | MPA 81 A 600 |
| MPA 81 B On/Off delay | | 1 common relay and 1 common NPN/PNP | MPA 81 B 703 | MPA 81 B 702 | MPA 81 B 701 | MPA 81 B 700 |
| | | 8 individual relays | MPA 81 C 503 | MPA 81 C 502 | MPA 81 C 501 | MPA 81 C 500 |
| MPA 81 C | | 8 individual NPN/PNP | MPA 81 C 603 | MPA 81 C 602 | MPA 81 C 601 | MPA 81 C 600 |
| | | MPA 81 D On/Off delay | 1 common relay and 1 common NPN/PNP | MPA 81 D 703 | MPA 81 D 702 | MPA 81 D 701 |

Note: Remote sensors to be ordered separately.

Applicable Remote Sensors and Ranges

| Series | Thru Beam | Diffuse Proximity |
|-------------------|-----------|-------------------|
| MPA 81 A/B | | |
| 100 | 8 m | 65 cm |
| 110 | 18 m | 1,3 m |
| 120 | 35 m | 3 m |
| MPA 81 C/D | | |
| 100 | 4 m | 35 cm |
| 110 | 9 m | 70 cm |
| 120 | 18 m | 2 m |

Wiring Diagrams

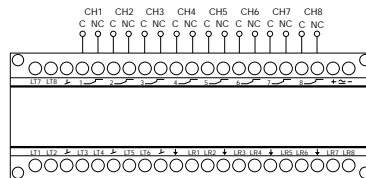

MPA 81A/C50X (Relay Output)

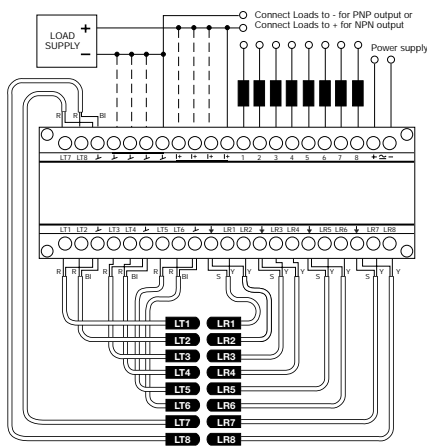

| Wire Code | |
|-----------|--------|
| R | Red |
| BI | Black |
| Y | Yellow |
| S | Shield |

MPA 81A/C60X (Transistor Output)

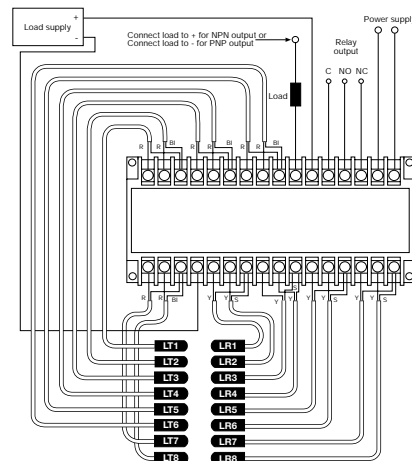

| Wire Code | |
|-----------|--------|
| R | Red |
| BI | Black |
| Y | Yellow |
| S | Shield |

MPA 81 B/D

Dimensions and Descriptions

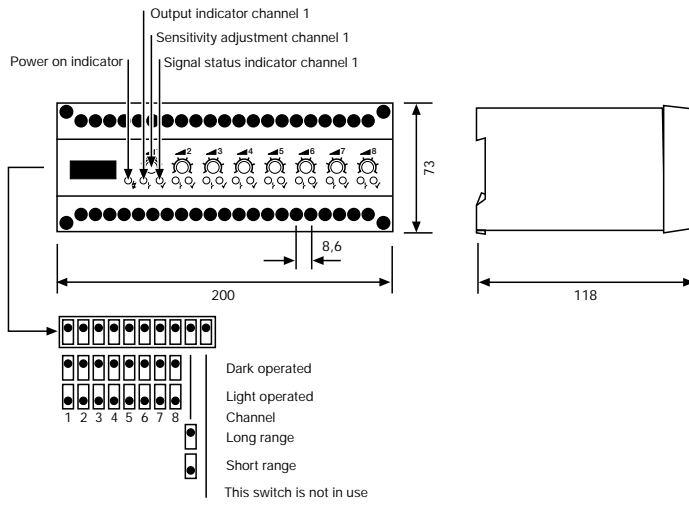

MPA 81 A/C

(Units in mm)

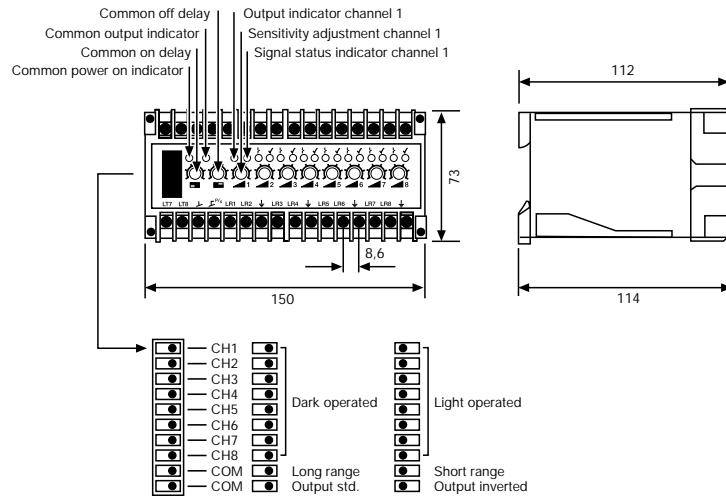

MPA 81 B/D

(Units in mm)

Telco reserves the right to change specifications without notice.

Description

- Operation mode and max sensing range:
Thru beam: 1-12 m
- Cable or plug connection
- Sensitivity adjustment via control input
- Wide variety of housings
- Power and output indicator
- High tolerance to hostile environments
- 10 – 30 V dc supply voltage
- 3 wire, NPN or PNP transistor output

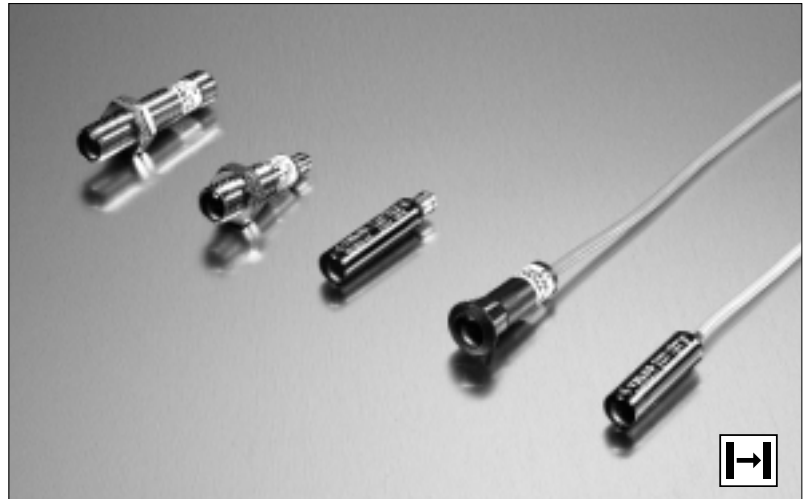

The 3000 series consists of a low cost self-contained transmitter SMT, and a receiver SMR, which are to be used in thru beam mode. The complete series is available in a wide range of housings with either cable or plug connection.

The SMR is supplied with a 10-30 V dc supply voltage with a 3 wire, NPN or PNP transistor output with a choice between light or dark function.

The control input in the SMT may be used for either disabling or enabling the transmitting power temporarily for test purpose, multiplexing applications or as a gradual regulation of the transmitting power level.

Both the transmitter and receiver are protected against reverse polarity of power supplies, control input and output signals. The output is also protected against short circuit and inductive loads.

Technical Data

| | SMT 3000C | SMT 3012C | SMR 3X06 | SMR 3X12 |
|----------------------------------|-------------------|-----------|-----------------|----------|
| Supply voltage | 10 – 30 V dc | | | |
| Voltage ripple | 15% | | | |
| Reverse polarity protected | Yes | | | |
| Short circuit protected | – | | Yes | |
| Power consumption | Max. 30 mA | | Max. 8 mA | |
| Maximum output load | – | | 100 mA | |
| Maximum residual voltage | – | | 2,5 V | |
| Maximum operation frequency | – | | > 125 Hz | |
| Response time t_{ON} / t_{OFF} | – | | < 4 ms / < 6 ms | |
| Power on indicator | Green LED | | – | |
| Output indicator | – | | Yellow LED | |
| Hysteresis | – | | Approx. 25 % | |
| Transmitter diode | Ga Al As (880 nm) | | – | |
| Opening angle | – | | +/- 10° | +/- 8° |
| Emission angle | +/- 11° | +/- 5° | – | |

Environmental Data

| | | | |
|--------------------------------|--------------------|------------|------------|
| Vibration | 10 – 55 Hz, 0,5 mm | | |
| Shock | 30 g | | |
| Light immunity, @ 5° incidence | – | 35 000 lux | 12 000 lux |
| Temperature, operation | – 20 to +50 °C | | |
| Temperature, storage | – 40 to +80 °C | | |
| Sealing class | IP 67 | | |
| Approvals | CE | | |

| Available Types | | | | | | | | | |
|-----------------|-------|---------------------------------|--------|---------------------|----------------------|-----------------|-----------------|-----------------|------------|
| | Type | Control Feature | Output | Connection | | 5 m Cable | 3 pin, M8 Plug | 4 pin, M12 Plug | Range |
| | | | | Housing Material | Housing Size | Order Reference | | | |
| Transmitter | 3000C | Adjustable range and test input | | Polycarbonate | Ø10 | SMT 3000C AP 5 | SMT 3000C AP T3 | - | 1-6 metres |
| | | | | | M12 x 1 | SMT 3000C TP 5 | SMT 3000C TP T3 | - | |
| | | | | Nickel Plated Brass | | | SMT 3000C TB 5 | SMT 3000C TB T3 | |
| | | | | ABS | Ø12,7 (Snap Housing) | SMT 3000C S 5* | - | - | |

| | | | | | | | | | |
|-------------|-------|---------------------------------|--|---------------------|---------|----------------|-----------------|-----------------|-------------|
| Transmitter | 3012C | Adjustable range and test input | | Polycarbonate | Ø10 | SMT 3012C AP 5 | SMT 3012C AP T3 | - | 1-12 metres |
| | | | | | M12 x 1 | SMT 3012C TP 5 | SMT 3012C TP T3 | - | |
| | | | | Nickel Plated Brass | | | SMT 3012C TB 5 | SMT 3012C TB T3 | |

| | | | | | | | | | |
|----------|------|--------------------------|-----|----------------------|---------------|---------------|----------------|----------------|----------|
| Receiver | 3006 | NPN, NC (light operated) | | Polycarbonate | Ø10 | SMR 3006 AP 5 | SMR 3006 AP T3 | - | 6 metres |
| | | | | | M12 x 1 | SMR 3006 TP 5 | SMR 3006 TP T3 | - | |
| | | | | Nickel Plated Brass | | | SMR 3006 TB 5 | SMR 3006 TB T3 | |
| | 3106 | NPN, NO (dark operated) | | Polycarbonate | Ø10 | SMR 3106 AP 5 | SMR 3106 AP T3 | - | |
| | | | | | M12 x 1 | SMR 3106 TP 5 | SMR 3106 TP T3 | - | |
| | | | | Nickel Plated Brass | | | SMR 3106 TB 5 | SMR 3106 TB T3 | |
| | 3206 | PNP, NC (light operated) | | Polycarbonate | Ø10 | SMR 3206 AP 5 | SMR 3206 AP T3 | - | |
| | | | | | M12 x 1 | SMR 3206 TP 5 | SMR 3206 TP T3 | - | |
| | | | | Nickel Plated Brass | | | SMR 3206 TB 5 | SMR 3206 TB T3 | |
| | 3306 | PNP, NO (dark operated) | | Polycarbonate | Ø10 | SMR 3306 AP 5 | SMR 3306 AP T3 | - | |
| | | | | | M12 x 1 | SMR 3306 TP 5 | SMR 3306 TP T3 | - | |
| | | | | Nickel Plated Brass | | | SMR 3306 TB 5 | SMR 3306 TB T3 | |
| | | | ABS | Ø12,7 (Snap Housing) | SMR 3306 S 5* | - | - | | |

| | | | | | | | | | |
|----------|------|--------------------------|--|---------------------|---------|---------------|----------------|----------------|-----------|
| Receiver | 3012 | NPN, NC (light operated) | | Polycarbonate | Ø10 | SMR 3012 AP 5 | SMR 3012 AP T3 | - | 12 metres |
| | | | | | M12 x 1 | SMR 3012 TP 5 | SMR 3012 TP T3 | - | |
| | | | | Nickel Plated Brass | | | SMR 3012 TB 5 | SMR 3012 TB T3 | |
| | 3112 | NPN, NO (dark operated) | | Polycarbonate | Ø10 | SMR 3112 AP 5 | SMR 3112 AP T3 | - | |
| | | | | | M12 x 1 | SMR 3112 TP 5 | SMR 3112 TP T3 | - | |
| | | | | Nickel Plated Brass | | | SMR 3112 TB 5 | SMR 3112 TB T3 | |
| | 3212 | PNP, NC (light operated) | | Polycarbonate | Ø10 | SMR 3212 AP 5 | SMR 3212 AP T3 | - | |
| | | | | | M12 x 1 | SMR 3212 TP 5 | SMR 3212 TP T3 | - | |
| | | | | Nickel Plated Brass | | | SMR 3212 TB 5 | SMR 3212 TB T3 | |
| | 3312 | PNP, NO (dark operated) | | Polycarbonate | Ø10 | SMR 3312 AP 5 | SMR 3312 AP T3 | - | |
| | | | | | M12 x 1 | SMR 3312 TP 5 | SMR 3312 TP T3 | - | |
| | | | | Nickel Plated Brass | | | SMR 3312 TB 5 | SMR 3312 TB T3 | |

Note: Sensors marked * do not have power on or output indicators incorporated.
6m transmitters only work with 6m receivers.
12m transmitters only work with 12m receivers.

Connections

| | Cable | M8 Plug/Cable | M12 Plug/Cable |
|-------------|-------|---------------|----------------|
| Supply + | Brown | Pin 1/Brown | Pin 1/Brown |
| Supply - | Blue | Pin 3/Blue | Pin 3/Blue |
| SMT control | Black | Pin 4/Black | Pin 4/Black |
| SMR output | Black | Pin 4/Black | Pin 3/Black |

3 pin, M8

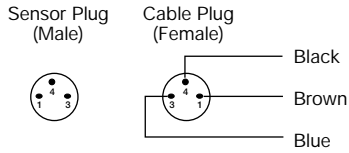

4 pin, M12

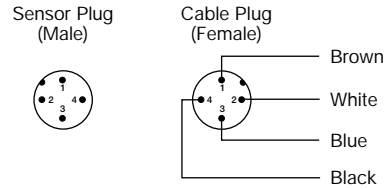

Wiring Diagrams

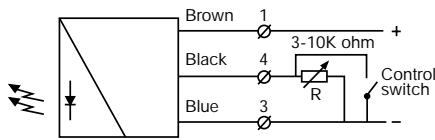

SMT 30XXC 1-6 m variable range and ON/OFF switch for transmitting power

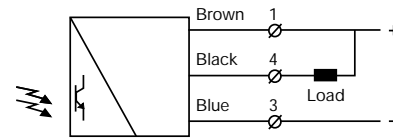

SMR 30XX / 31XX

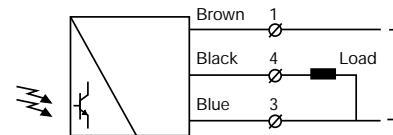

SMR 32XX / 33XX

Dimensions and Descriptions

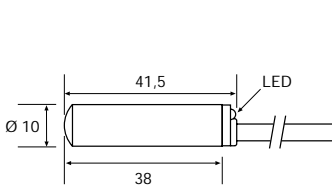

AP 2,5/5

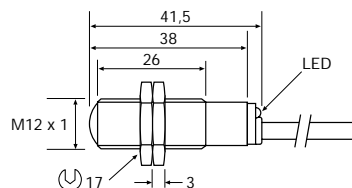

TP/TB 2,5/5

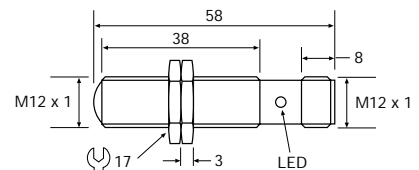

TB J

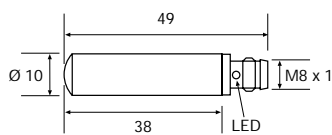

AP T3

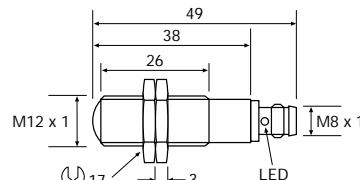

TP/TB T3

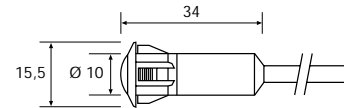

S 2,5/5

(Units in mm)

Telco reserves the right to change specifications without notice.

Description

- Operation mode and max sensing range:
Thru beam: 1-6 m
- Cable or plug connection
- Sensitivity adjustment via control input
- Wide variety of housings
- Power and output indicators
- High tolerance to hostile environments
- 10 – 32 V dc supply voltage
- 3 wire, NPN or PNP output or
 4 wire, NPN/PNP opto isolated output
- 5 or 0,5 ms response time
- Low current consumption

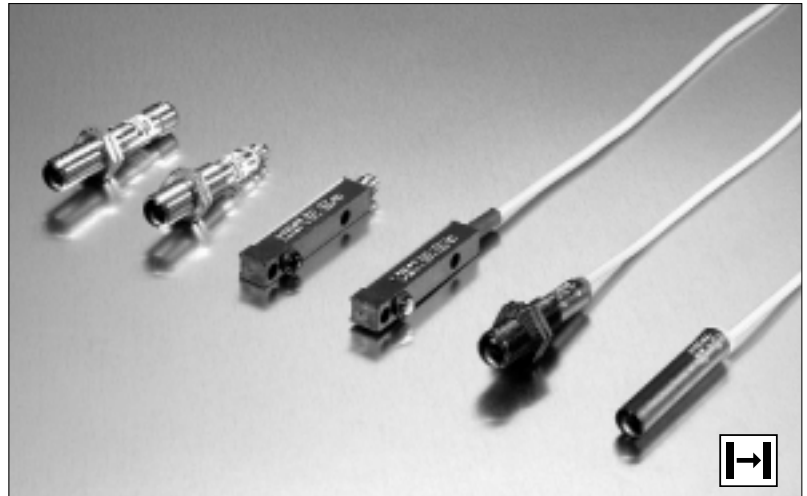

The 6000 series consists of a self-contained transmitter SMT, and a receiver SMR, which are to be used in thru beam mode. The complete series is available in a wide range of housings with either plug or cable connection.

The SMR is supplied with a 10-32 V dc supply voltage with either a 3 wire, NPN or PNP or as a 4 wire, NPN/PNP opto-isolated transistor output with a choice between light or dark function. The SMR is available with either a 0.5 ms response time with a 2 metre range, or with a 5 ms

response time with a 6 metre range. The control input in the SMT may be used for either disabling or enabling the transmitting power temporarily for test purpose, multiplexing applications or as a gradual regulation of the transmitting power level.

Both the transmitter and receiver are protected against reverse polarity of power supplies, control input and output signals. The output is also protected against short circuit and inductive loads.

| Technical Data | SMT | SMR | |
|----------------------------------|-------------------|-------------|-----------------|
| | | 6x06 | 6x02 |
| Supply voltage | 10 – 32 V dc | | |
| Voltage ripple | 15 % | | |
| Reverse polarity protected | Yes | | |
| Short circuit protected | - | Yes | |
| Power consumption | 10 mA @ 32 V dc | | |
| Maximum output load | - | 100 mA | |
| Maximum residual voltage | - | 2,5 V | |
| Maximum operation frequency | - | 100 Hz | 1000 Hz |
| Response time t_{ON} / t_{OFF} | - | 5 ms / 5 ms | 0,5 ms / 0,5 ms |
| Power on indicator | Green LED | - | |
| Output indicator | - | Yellow LED | |
| Hysteresis | - | Approx. 30% | |
| Transmitter diode | Ga Al As (880 nm) | - | |
| Opening angle | - | +/- 6° | |
| Emission angle | +/- 10° | - | |

| Environmental Data | |
|--------------------------------|--------------------|
| Vibration | 10 – 55 Hz, 0,5 mm |
| Shock | 30 g |
| Light immunity, @ 5° incidence | >50 000 lux |
| Temperature, operation | -20 to +60 °C |
| Temperature, storage | -40 to +80 °C |
| Sealing class | IP 67 |
| Approvals | CE |

| Available Types | | | | | | | | | | |
|-----------------|------|---------------------------------|--------|------------------|--------------|----------------|----------------|----------------|-----------------|--------------|
| | Type | Control Feature | Output | Connection | | 5 m Cable | 3 pin, M8 Plug | 4 pin, M8 Plug | 4 pin, M12 Plug | Range |
| | | | | Housing Material | Housing Size | | | | | |
| Transmitter | 6000 | Adjustable range and test input | | Polycarbonate | Ø10 | SMT 6000 AP 5 | SMT 6000 AP T3 | - | - | 1 – 6 metres |
| | | | | | M12 x 1 | SMT 6000 TP 5 | SMT 6000 TP T3 | - | - | |
| | | | | Stainless Steel | Ø10 | SMT 6000 AS 5 | SMT 6000 AS T3 | SMT 6000 AS T4 | - | |
| | | | | | M12 x 1 | SMT 6000 TS 5 | SMT 6000 TS T3 | SMT 6000 TS T4 | SMT 6000 TS J | |
| | | | | Polyester | □ 9,5 x 11,5 | SMT 6000 SG 5* | SMT 6000 SG T3 | - | - | |

| | | | | | | | | | | |
|----------|-----------|------------------------------|----------------|-----------------|---------|---------------|----------------|----------------|---------------|----------|
| Receiver | 6006 | NPN, NC (light operated) | | Polycarbonate | Ø10 | SMR 6006 AP 5 | SMR 6006 AP T3 | - | - | 6 metres |
| | | | | | M12 x 1 | SMR 6006 TP 5 | SMR 6006 TP T3 | - | - | |
| | | | | Stainless Steel | Ø10 | SMR 6006 AS 5 | SMR 6006 AS T3 | - | - | |
| | | | | | M12 x 1 | SMR 6006 TS 5 | SMR 6006 TS T3 | - | SMR 6006 TS J | |
| | Polyester | □ 9,5 x 11,5 | SMR 6006 SG 5* | SMR 6006 SG T3 | - | - | | | | |
| | 6106 | NPN, NO (dark operated) | | Polycarbonate | Ø10 | SMR 6106 AP 5 | SMR 6106 AP T3 | - | - | |
| | | | | | M12 x 1 | SMR 6106 TP 5 | SMR 6106 TP T3 | - | - | |
| | | | | Stainless Steel | Ø10 | SMR 6106 AS 5 | SMR 6106 AS T3 | - | - | |
| | | | | | M12 x 1 | SMR 6106 TS 5 | SMR 6106 TS T3 | - | SMR 6106 TS J | |
| | Polyester | □ 9,5 x 11,5 | SMR 6106 SG 5* | SMR 6106 SG T3 | - | - | | | | |
| | 6206 | PNP, NC (light operated) | | Polycarbonate | Ø10 | SMR 6206 AP 5 | SMR 6206 AP T3 | - | - | |
| | | | | | M12 x 1 | SMR 6206 TP 5 | SMR 6206 TP T3 | - | - | |
| | | | | Stainless Steel | Ø10 | SMR 6206 AS 5 | SMR 6206 AS T3 | - | - | |
| | | | | | M12 x 1 | SMR 6206 TS 5 | SMR 6206 TS T3 | - | SMR 6206 TS J | |
| | Polyester | □ 9,5 x 11,5 | SMR 6206 SG 5* | SMR 6206 SG T3 | - | - | | | | |
| | 6306 | PNP, NO (dark operated) | | Polycarbonate | Ø10 | SMR 6306 AP 5 | SMR 6306 AP T3 | - | - | |
| | | | | | M12 x 1 | SMR 6306 TP 5 | SMR 6306 TP T3 | - | - | |
| | | | | Stainless Steel | Ø10 | SMR 6306 AS 5 | SMR 6306 AS T3 | - | - | |
| | | | | | M12 x 1 | SMR 6306 TS 5 | SMR 6306 TS T3 | - | SMR 6306 TS J | |
| | Polyester | □ 9,5 x 11,5 | SMR 6306 SG 5* | SMR 6306 SG T3 | - | - | | | | |
| | 6406 | NPN/PNP, NO (dark operated) | | Stainless Steel | Ø10 | - | - | SMR 6406 AS T4 | - | |
| | | | | | M12 x 1 | - | - | SMR 6406 TS T4 | SMR 6406 TS J | |
| | 6506 | NPN/PNP, NC (light operated) | | Stainless Steel | Ø10 | - | - | SMR 6506 AS T4 | - | |
| | | | | | M12 x 1 | - | - | SMR 6506 TS T4 | SMR 6506 TS J | |

Note: Sensors marked * do not have power on or output indicators incorporated.

| Type | Control Feature | Output | Connection | | 5m Cable | 3 pin, M8 Plug | 4 pin, M8 Plug | 4 pin, M12 Plug | Range | |
|----------|------------------------------|--------------------------|-------------------------|-----------------|----------------|----------------|----------------|-----------------|----------|-----------------|
| | | | Housing Material | Housing Size | | | | | | Order Reference |
| Receiver | 6002 | NPN, NC (light operated) | Polycarbonate | Ø10 | SMR 6002 AP 5 | SMR 6002 AP T3 | - | - | 2 metres | |
| | | | | M12 x 1 | SMR 6002 TP 5 | SMR 6002 TP T3 | - | - | | |
| | | | Stainless Steel | Ø10 | SMR 6002 AS 5 | SMR 6002 AS T3 | - | - | | |
| | | | | M12 x 1 | SMR 6002 TS 5 | SMR 6002 TS T3 | - | SMR 6002 TS J | | |
| | | | Polyester | □ 9,5 x 11,5 | SMR 6002 SG 5* | SMR 6002 SG T3 | - | - | | |
| | | | | | | | | | | |
| | | 6102 | NPN, NO (dark operated) | Polycarbonate | Ø10 | SMR 6102 AP 5 | SMR 6102 AP T3 | - | | - |
| | | | | | M12 x 1 | SMR 6102 TP 5 | SMR 6102 TP T3 | - | | - |
| | | | | Stainless Steel | Ø10 | SMR 6102 AS 5 | SMR 6102 AS T3 | - | | - |
| | | | | | M12 x 1 | SMR 6102 TS 5 | SMR 6102 TS T3 | - | | SMR 6102 TS J |
| | | | | Polyester | □ 9,5 x 11,5 | SMR 6102 SG 5* | SMR 6102 SG T3 | - | | - |
| | | | | | | | | | | |
| | 6202 | PNP, NC (light operated) | Polycarbonate | Ø10 | SMR 6202 AP 5 | SMR 6202 AP T3 | - | - | | |
| | | | | M12 x 1 | SMR 6202 TP 5 | SMR 6202 TP T3 | - | - | | |
| | | | Stainless Steel | Ø10 | SMR 6202 AS 5 | SMR 6202 AS T3 | - | - | | |
| | | | | M12 x 1 | SMR 6202 TS 5 | SMR 6202 TS T3 | - | SMR 6202 TS J | | |
| | | | Polyester | □ 9,5 x 11,5 | SMR 6202 SG 5* | SMR 6202 SG T3 | - | - | | |
| | | | | | | | | | | |
| | 6302 | PNP, NO (dark operated) | Polycarbonate | Ø10 | SMR 6302 AP 5 | SMR 6302 AP T3 | - | - | | |
| | | | | M12 x 1 | SMR 6302 TP 5 | SMR 6302 TP T3 | - | - | | |
| | | | Stainless Steel | Ø10 | SMR 6302 AS 5 | SMR 6302 AS T3 | - | - | | |
| | | | | M12 x 1 | SMR 6302 TS 5 | SMR 6302 TS T3 | - | SMR 6302 TS J | | |
| | | | Polyester | □ 9,5 x 11,5 | SMR 6302 SG 5* | SMR 6302 SG T3 | - | - | | |
| | | | | | | | | | | |
| 6402 | NPN/PNP, NO (dark operated) | Stainless Steel | Ø10 | - | - | SMR 6402 AS T4 | SMR 6402 AS J | | | |
| | | | M12 x 1 | - | - | SMR 6402 TS T4 | SMR 6402 TS J | | | |
| 6502 | NPN/PNP, NC (light operated) | Stainless Steel | Ø10 | - | - | SMR 6502 AS T4 | SMR 6502 AS J | | | |
| | | | M12 x 1 | - | - | SMR 6502 TS T4 | SMR 6502 TS J | | | |

Note: Sensors marked * do not have power on or output indicators incorporated.

| Connections | | | |
|----------------|-------|---------------|----------------|
| | Cable | M8 Plug/Cable | M12 Plug/Cable |
| Supply + | Brown | Pin 1/Brown | Pin 1/Brown |
| Supply - | Blue | Pin 3/Blue | Pin 3/Blue |
| Control/output | Black | Pin 4/Black | Pin 4/Black |
| SMR output | White | Pin 2/White | Pin 2/White |

| | | |
|------------------|------------------|-------------------|
| 3 pin, M8 | 4 pin, M8 | 4 pin, M12 |
| | | |

Wiring Diagrams

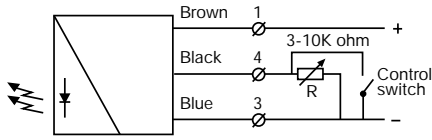

SMT 6000 1-6 m variable range and ON/OFF switch for transmitting power

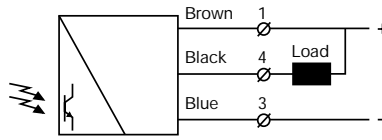

SMR 600X / 610X

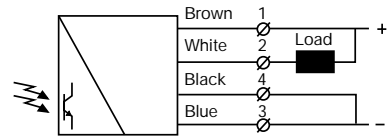

SMR 640X / 650X (Load as NPN)

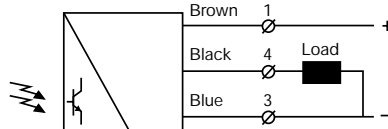

SMR 620X / 630X

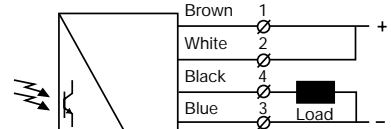

SMR 640X / 650X (Load as PNP)

Dimensions and Descriptions

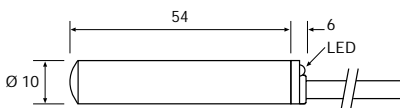

AP/AS 5

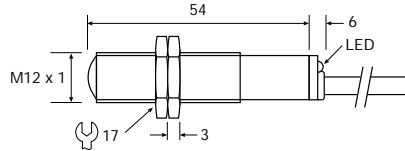

TP/TS 5

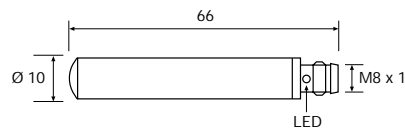

AP/AS T3/T4

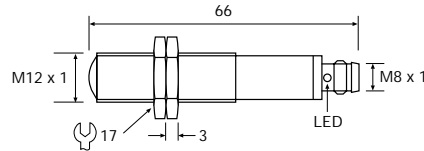

TP/TS T3/T4

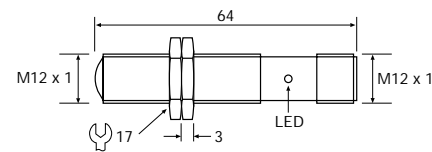

TS J

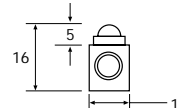

SG 5

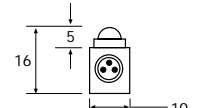

SG T3

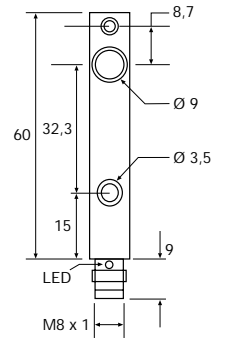
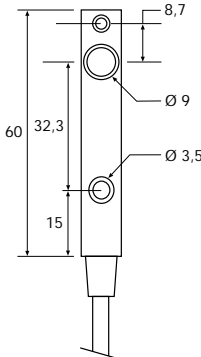

(Units in mm)

Telco reserves the right to change specifications without notice.

Description

- Operation mode and max sensing range:
Thru beam: 0-20 m
Diffuse proximity: 0-50 cm
Retro reflective: 0-3 m
Fibre: Dependent on fibre optic
- Cable or plug connection
- Sensitivity adjustment via potentiometer
- Switch selectable light or dark function
- Power and output indicators
- High tolerance to hostile environments
- 10-30 V dc supply voltage
- 4 wire, NPN/PNP transistor output or 4 wire, ambivalent PNP/PNP transistor output
- Test input

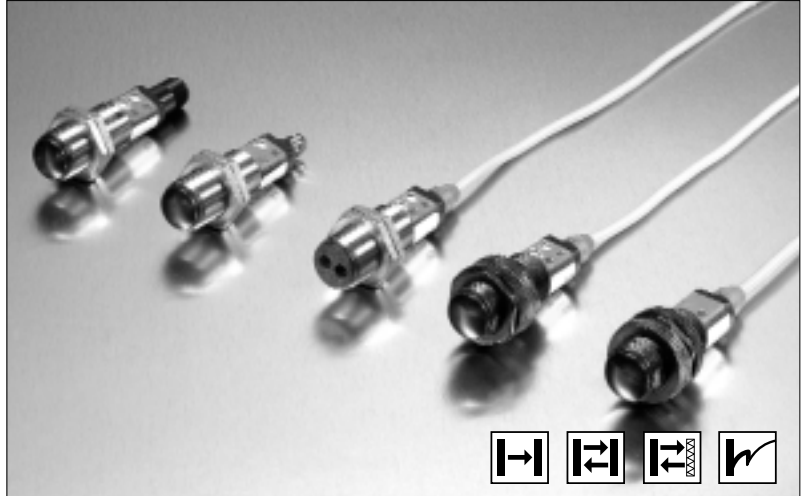

The 7000 series consists of a self-contained transmitter SMT, and a receiver SMR which are to be used in thru beam mode, an SMP for diffuse proximity, SMRR for retro reflective and an SMPF for use with fibre optic cables. All are offered with sensitivity adjustment via integral potentiometer with either cable or plug connection.

The complete series is available either as 4 wire, NPN/PNP transistor output or 4 wire ambivalent PNP/PNP output with a 10-30 V dc supply voltage, both offering switch selectable light or dark function. The SMR

is available with either a 0.5 ms response time and a 7 metre range or with a 2 ms response time with a 20 metre range. The control input in the SMT is intended to be used for disabling or enabling the transmitting power temporarily for test purpose or for multiplexing applications.

The complete series is protected against reverse polarity of power supplies, control input and output signals. The output is protected against short circuit and inductive loads.

| Technical Data | SMT | SMR | | SMP/SMPF | SMRR |
|----------------------------------|-------------------|-------------------|-------------|------------------|----------|
| | | 7x07 | 7x20 | | |
| Supply voltage | | 10 – 30 V dc | | | |
| Voltage ripple | | 15 % | | | |
| Reverse polarity protected | | Yes | | | |
| Short circuit protected | - | Yes | | | |
| Power consumption | 25 mA | 20 mA | | | |
| Maximum output load | - | 120 mA / 30 V dc | | | |
| Maximum residual voltage | - | 2 V | | 1,5 V | |
| Maximum operation frequency | - | 1000 Hz | 250 Hz | | |
| Response time t_{ON} / t_{OFF} | - | 0,5 ms / 0,5 ms | 2 ms / 2 ms | | |
| Power on indicator | | Green LED | | | |
| Output indicator | - | Yellow LED | | | |
| Hysteresis | - | Approx. 15 – 20 % | | Approx. 3 – 10 % | |
| Transmitter diode | Ga Al As (880 nm) | - | | | |
| Opening angle | - | +/- 5° | | +/- 4° | +/- 1,5° |
| Emission angle | +/- 4° | - | | | |

| Environmental Data | | | | | |
|--------------------------------|--------------------|--------------|------|--------------|-----------|
| | SMT | SMR | | SMP | SMRR/SMPF |
| | | 7x07 | 7x20 | | |
| Vibration | 10 – 55 Hz, 0,5 mm | | | | |
| Shock | 30 g | | | | |
| Light immunity, @ 5° incidence | - | > 20 000 lux | | > 10 000 lux | |
| Temperature, operation | - 20 to +60 °C | | | | |
| Temperature, storage | - 40 to +80 °C | | | | |
| Sealing class | IP 67 | | | | |
| Approvals | CE | | | | |

| Available Types | | | | | | | | | | |
|-------------------------|-------------|--------------|--|---------|------------------|--------------|-----------------------|------------------------|-----------------------|-----------------------------|
| | Type | Power Supply | Control Feature | Output | Connection | | 5 m Cable | 4 pin, M8 Plug | 4 pin, M12 Plug | Range |
| | | | | | Housing Material | Housing Size | | | | |
| Transmitter | 7000 | 10-30 V dc | Test input | | Polycarbonate | M18 x 1 | SMT 7000 TP 5 | SMT 7000 TP T4 | SMT 7000 TP J | 20 metres |
| | | | | | Stainless Steel | | SMT 7000 TS 5 | SMT 7000 TS T4 | SMT 7000 TS J | |
| Receiver | 7607 | 10-30 V dc | Sensitivity pot. and light/dark switch | NPN/PNP | Polycarbonate | M18 x 1 | SMR 7607 TP 5 | SMR 7607 TP T4 | SMR 7607 TP J | 0-7 metres |
| | | | | | Stainless Steel | | SMR 7607 TS 5 | SMR 7607 TS T4 | SMR 7607 TS J | |
| | 7620 | | | | Polycarbonate | | SMR 7620 TP 5 | SMR 7620 TP T4 | SMR 7620 TP J | 0-20 metres |
| | | | | | Stainless Steel | | SMR 7620 TS 5 | SMR 7620 TS T4 | SMR 7620 TS J | |
| | 7707 | | Sensitivity pot. | PNP/PNP | Polycarbonate | | SMR 7707 TP 5 | SMR 7707 TP T4 | SMR 7707 TP J | 0-7 metres |
| | | | | | Stainless Steel | | SMR 7707 TS 5 | SMR 7707 TS T4 | SMR 7707 TS J | |
| | 7720 | | | | Polycarbonate | | SMR 7720 TP 5 | SMR 7720 TP T4 | SMR 7720 TP J | 0-20 metres |
| | | | | | Stainless Steel | | SMR 7720 TS 5 | SMR 7720 TS T4 | SMR 7720 TS J | |
| Proximity | 7600 | 10-30 V dc | Sensitivity pot. and light/dark switch | NPN/PNP | Polycarbonate | M18 x 1 | SMP 7600 TP 5 | SMP 7600 TP T4 | SMP 7600 TP J | 0-50 cm |
| | | | | | Stainless Steel | | SMP 7600 TS 5 | SMP 7600 TS T4 | SMP 7600 TS J | |
| Fibre Sensors | 7600 | 10-30 V dc | Sensitivity pot. and light/dark switch | NPN/PNP | Polycarbonate | M18 x 1 | SMPF 7600 TP 5 | SMPF 7600 TP T4 | SMPF 7600 TP J | For ranges refer to page 44 |
| | | | | | Stainless Steel | | SMPF 7600 TS 5 | SMPF 7600 TS T4 | SMPF 7600 TS J | |
| Retro Reflective | 7600 | 10-30 V dc | Sensitivity pot. and light/dark switch | NPN/PNP | Polycarbonate | M18 x 1 | SMRR 7600 TP 5 | SMRR 7600 TP T4 | SMRR 7600 TP J | 0-3 metres |
| | | | | | Stainless Steel | | SMRR 7600 TS 5 | SMRR 7600 TS T4 | SMRR 7600 TS J | |

| Connections | | | |
|----------------|-------|---------------|----------------|
| | Cable | M8 Plug/Cable | M12 Plug/Cable |
| Supply + | Brown | Pin 1/Brown | Pin 1/Brown |
| Supply - | Blue | Pin 3/Blue | Pin 3/Blue |
| Control/output | Black | Pin 4/Black | Pin 4/Black |
| Output | White | Pin 2/White | Pin 2/White |

4 pin, M8

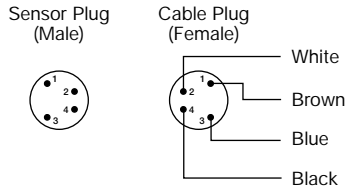

4 pin, M12

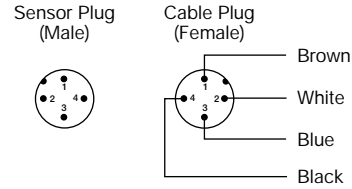

Wiring Diagrams

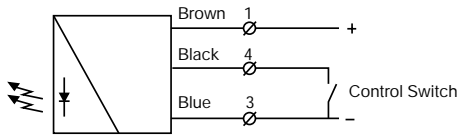

On/Off switch for transmitter power

SMT 7000

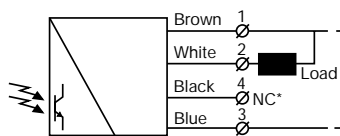

*Do not connect black wire

SMR 76XX (load as NPN)

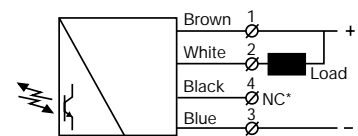

*Do not connect black wire

SMP/SMPF/SMRR 7600 (load as NPN)

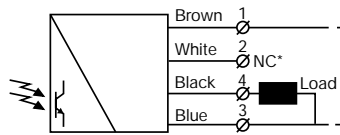

*Do not connect white wire

SMR 76XX (load as PNP)

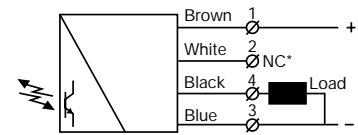

*Do not connect white wire

SMP/SMPF/SMRR 7600 (load as PNP)

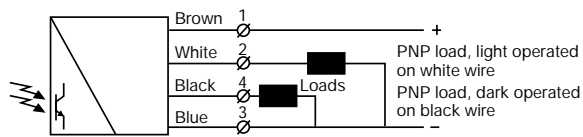

SMR 77XX

Dimensions and Descriptions

Transmitter Models

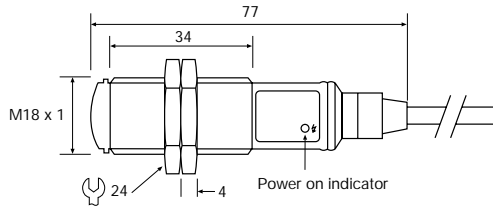

SMT 7000 TP/TS 5

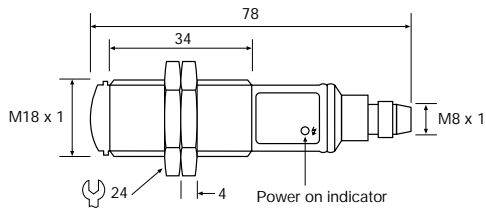

SMT 7000 TP/TS T4

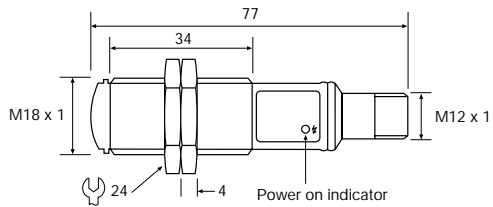

SMT 7000 TP/TS J

(Units in mm)

Receiver Models

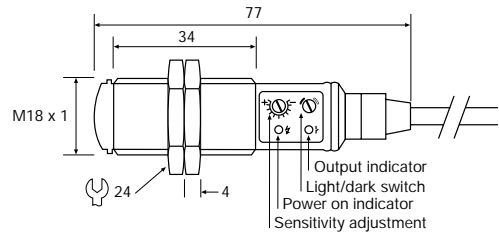

SMR/SMP/SMPF/SMRR 76XX TP/TS 5

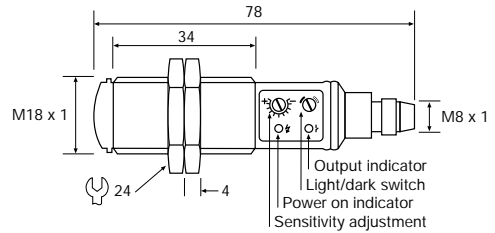

SMR/SMP/SMPF/SMRR 76XX TP/TS T4

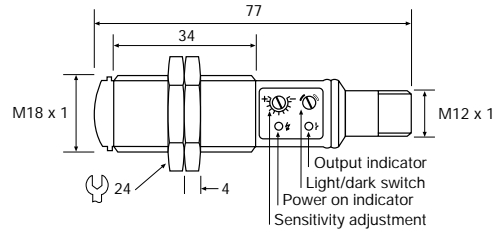

SMR/SMP/SMPF/SMRR 76XX TP/TS J

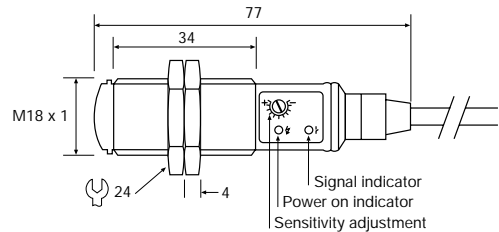

SMR 77XX TP/TS 5

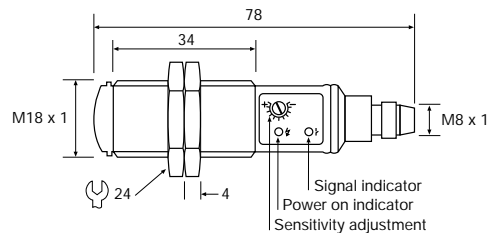

SMR 77XX TP/TS T4

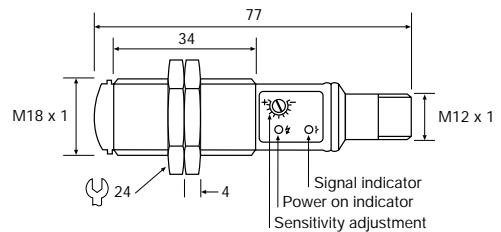

SMR 77XX TP/TS J

(Units in mm)

Telco reserves the right to change specifications without notice.

Description

- Operation mode and max sensing range:
Thru beam: 0-20 m
Diffuse proximity: 0-50 cm
Retro reflective: 0-3 m
Fibre: Dependent on fibre optic
- Cable or plug connection
- Sensitivity adjustment via potentiometer
- Switch selectable light or dark function
- Power and output indicators
- High tolerance to hostile environments
- 10-30 V dc or 20-250 V ac supply voltage
- 3 wire, NPN or PNP transistor output
or 2 wire, SCR output
- Test input

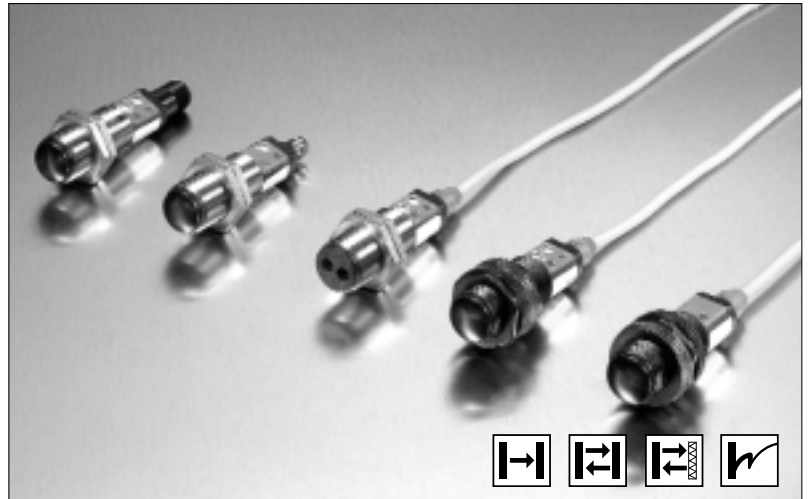



The 8000 series consists of a self-contained transmitter SMT, and a receiver SMR which are to be used in thru beam mode, an SMP for diffuse proximity, SMRR for retro reflective and an SMPF for use with fibre optic cables. All are offered with sensitivity adjustment via integral potentiometer with either cable or plug connection.

The complete series is available either as 3 wire, NPN or PNP transistor output with a 10-30 V dc supply voltage, or as 2 wire, SCR with a

20-250 V ac supply voltage both offering switch selectable light or dark function. The control input in the 10-30 V dc SMT is intended to be used for disabling or enabling the transmitting power temporarily for test purpose or for multiplexing applications.

The dc series is protected against reverse polarity of power supplies, control input and output signals. The output is protected against short circuit and inductive loads.

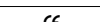
| | | Technical Data | | | | |
|--|----|-------------------|-------------------|---------------|------------------|----------|
| | | SMT | SMR | | SMP/SMPF | SMRR |
| | | | 8x20 | 8x00 | | |
| Supply voltage | ac | 20 – 250 V ac | - | 20 – 250 V ac | | |
| | dc | | | 10 – 30 V dc | | |
| Voltage ripple | | | | | 15 % | |
| Reverse polarity protected | dc | | | | Yes | |
| Short circuit protected | dc | - | | | Yes | |
| Power consumption | ac | 3 mA | - | 2 mA | | |
| | dc | 15 mA | 5 mA | | 14 mA | |
| Maximum output load | ac | - | - | 200 mA | | |
| | dc | | 120 mA @ 30 V dc | | | |
| Maximum residual voltage | ac | - | - | 8 V | | |
| | dc | | 1,5 V | | | |
| Max. operation frequency | ac | - | - | 25 Hz | | |
| | dc | | 100 Hz | 250 Hz | | |
| Response time t _{ON} / t _{OFF} | ac | - | - | 25 ms / 25 ms | | |
| | dc | | 5 ms / 5 ms | 2 ms / 2 ms | | |
| Power on indicator | | | Green LED | | | |
| Output indicator | | - | Yellow LED | | | |
| Hysteresis | | - | Approx. 10 – 30 % | | Approx. 3 – 10 % | |
| Transmitter diode | | Ga Al As (880 nm) | - | | | |
| Opening angle | | - | +/- 5° | | +/- 4° | +/- 1,5° |
| Emission angle | | +/- 4° | - | | | |

| Environmental Data | | | | | |
|--------------------------------|--------------------|--|--------------|-----|-----------|
| | SMT | SMR | | SMP | SMRR/SMPF |
| | | 8x20 | 8x00 | | |
| Vibration | 10 – 55 Hz, 0,5 mm | | | | |
| Shock | 30 g | | | | |
| Light immunity, @ 5° incidence | - | > 7000 lux | > 10 000 lux | | |
| Temperature, operation | - 20 to +60 °C | | | | |
| Temperature, storage | - 40 to +80 °C | | | | |
| Sealing class | ac | IP 60 | | | |
| | dc | IP 67 | | | |
| Approvals | ac |    | | | |
| | dc |  | | | |

| Available Types | | | | | | | | | | |
|-----------------|------|--------------|-----------------|--------|------------------|----------------------|-----------|-----------------------|-----------------------|----------------------|
| Transmitter | Type | Power Supply | Control Feature | Output | Connection | | 5 m Cable | 3 pin, M8 Plug | 4 pin, M12 Plug | Range |
| | | | | | Housing Material | Housing Size | | | | |
| | 8000 | 10 – 30 V dc | Test Input | | | Polycarbonate | M18 x 1 | SMT 8000 PG 5 | SMT 8000 PG T3 | SMT 8000 PG J |
| Stainless Steel | | | | | | SMT 8000 MG 5 | | SMT 8000 MG T3 | SMT 8000 MG J | |
| 20 – 250 V ac | | - | Polycarbonate | | | SMT 8600 PG 5 | | - | - | 7 metres |
| | | | Stainless Steel | | | SMT 8600 MG 5 | | - | - | |

| | | | | | | | | | | | | |
|-----------|------|--------------|--|---------------|-------------------|---------|----------------------|-----------------------|----------------------|-------------|---|----------|
| Receivers | 8400 | 10 – 30 V dc | Sensitivity pot. and light/dark switch | NPN | Polycarbonate | M18 x 1 | SMR 8400 PG 5 | SMR 8400 PG T3 | SMR 8400 PG J | 0-7 metres | | |
| | | | | | Stainless Steel | | SMR 8400 MG 5 | SMR 8400 MG T3 | SMR 8400 MG J | | | |
| | 8500 | | | PNP | Polycarbonate | | SMR 8500 PG 5 | SMR 8500 PG T3 | SMR 8500 PG J | 0-20 metres | | |
| | | | | | Stainless Steel | | SMR 8500 MG 5 | SMR 8500 MG T3 | SMR 8500 MG J | | | |
| | 8520 | | | PNP | Polycarbonate | | SMR 8520 PG 5 | SMR 8520 PG T3 | SMR 8520 PG J | | | |
| | | | | | Stainless Steel | | SMR 8520 MG 5 | SMR 8520 MG T3 | SMR 8520 MG J | | | |
| | 8420 | | | NPN | Polycarbonate | | SMR 8420 PG 5 | SMR 8420 PG T3 | SMR 8420 PG J | | | |
| | | | | | Stainless Steel | | SMR 8420 MG 5 | SMR 8420 MG T3 | SMR 8420 MG J | | | |
| | 8800 | | | 20 – 250 V ac | Light/dark switch | | SCR | Polycarbonate | SMR 8800 PG 5 | - | - | 7 metres |
| | | | | | | | | Stainless Steel | SMR 8800 MG 5 | - | - | |

| | | | | | | | | | | | |
|-----------|------|--------------|--|---------------|-----------------|---------|----------------------|-----------------------|----------------------|---------|---|
| Proximity | 8500 | 10 – 30 V dc | Sensitivity pot. and light/dark switch | PNP | Polycarbonate | M18 x 1 | SMP 8500 PG 5 | SMP 8500 PG T3 | SMP 8500 PG J | 0-50 cm | |
| | | | | | Stainless Steel | | SMP 8500 MG 5 | SMP 8500 MG T3 | SMP 8500 MG J | | |
| | 8400 | | | NPN | Polycarbonate | | SMP 8400 PG 5 | SMP 8400 PG T3 | SMP 8400 PG J | | |
| | | | | | Stainless Steel | | SMP 8400 MG 5 | SMP 8400 MG T3 | SMP 8400 MG J | | |
| | 8800 | | | 20 – 250 V ac | SCR | | Polycarbonate | SMP 8800 PG 5 | - | | - |
| | | | | | | | Stainless Steel | SMP 8800 MG 5 | - | | - |

| | | | | | | | | | | | |
|---------------|------|--------------|--|---------------|-----------------|---------|-----------------------|------------------------|-----------------------|-----------------------------|---|
| Fibre Sensors | 8500 | 10 – 30 V dc | Sensitivity pot. and light/dark switch | PNP | Polycarbonate | M18 x 1 | SMPF 8500 PG 5 | SMPF 8500 PG T3 | SMPF 8500 PG J | For ranges refer to page 44 | |
| | | | | | Stainless Steel | | SMPF 8500 MG 5 | SMPF 8500 MG T3 | SMPF 8500 MG J | | |
| | 8400 | | | NPN | Polycarbonate | | SMPF 8400 PG 5 | SMPF 8400 PG T3 | SMPF 8400 PG J | | |
| | | | | | Stainless Steel | | SMPF 8400 MG 5 | SMPF 8400 MG T3 | SMPF 8400 MG J | | |
| | 8800 | | | 20 – 250 V ac | SCR | | Polycarbonate | SMPF 8800 PG 5 | - | | - |
| | | | | | | | Stainless Steel | SMPF 8800 MG 5 | - | | - |

Note: Fibre optic cable to be ordered separately.

| | | | | | | | | | | | |
|------------------|------|--------------|--|---------------|-----------------|---------|-----------------------|------------------------|-----------------------|------------|---|
| Retro Reflective | 8500 | 10 – 30 V dc | Sensitivity pot. and light/dark switch | PNP | Polycarbonate | M18 x 1 | SMRR 8500 PG 5 | SMRR 8500 PG T3 | SMRR 8500 PG J | 0-3 metres | |
| | | | | | Stainless Steel | | SMRR 8500 MG 5 | SMRR 8500 MG T3 | SMRR 8500 MG J | | |
| | 8400 | | | NPN | Polycarbonate | | SMRR 8400 PG 5 | SMRR 8400 PG T3 | SMRR 8400 PG J | | |
| | | | | | Stainless Steel | | SMRR 8400 MG 5 | SMRR 8400 MG T3 | SMRR 8400 MG J | | |
| | 8800 | | | 20 – 250 V ac | SCR | | Polycarbonate | SMRR 8800 PG 5 | - | | - |
| | | | | | | | Stainless Steel | SMRR 8800 MG 5 | - | | - |

Note: Reflector to be ordered separately.

Connections

| | Cable | M8 Plug/Cable | M12 Plug/Cable |
|------------|--------------|---------------|----------------|
| AC supply | Blue & Brown | - | - |
| Supply + | Brown | Pin 1/Brown | Pin 1/Brown |
| Supply - | Blue | Pin 3/Blue | Pin 3/Blue |
| Control | Red | Pin 4/Black | Pin 4/Black |
| SMR output | Black | Pin 4/Black | Pin 3/Black |

3 pin, M8

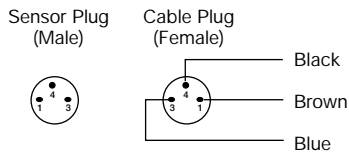

4 pin, M12

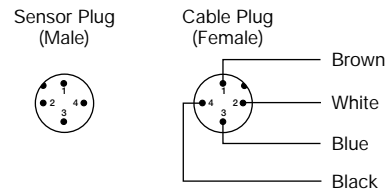

Wiring Diagrams

V ac Supply

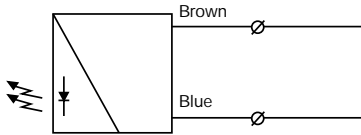

SMT 8600

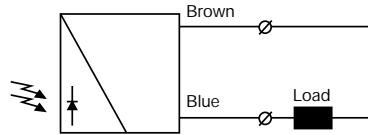

SMR 8800

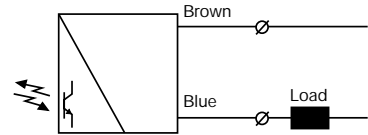

SMR / SMPF / SMRR 8800

V dc Supply

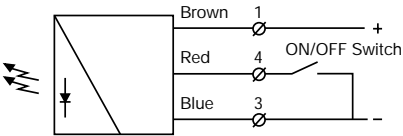

SMT 8000

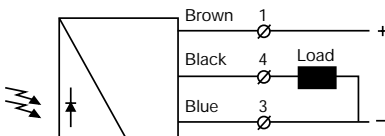

SMR 85XX

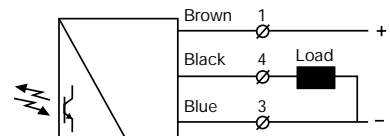

SMP / SMPF / SMRR 8500

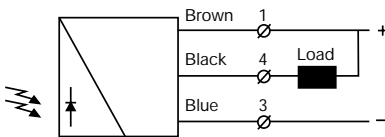

SMR 84XX

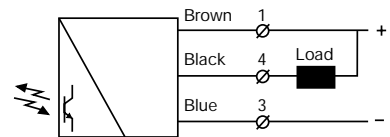

SMP / SMPF / SMRR 8400

Dimensions and Descriptions

AC Models

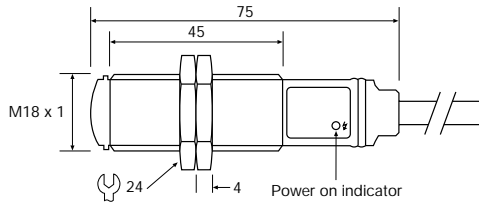

SMT PG/MG 5

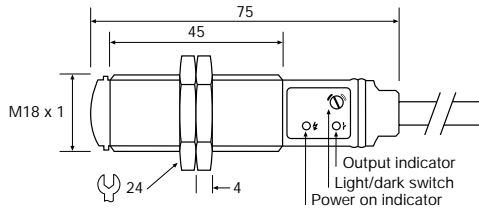

SMR PG/MG 5

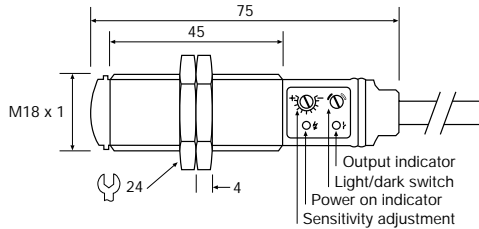

SMP/SMPF/SMRR PG/MG 5

DC Models

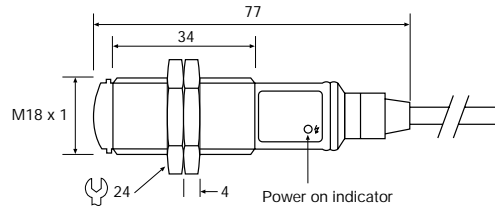

SMT PG/MG 5

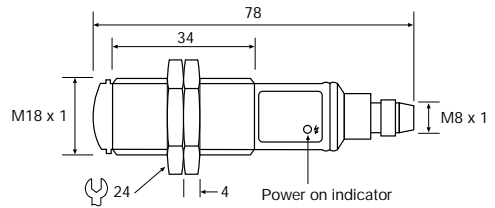

SMT PG/MG T3

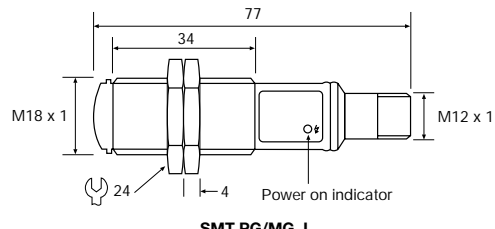

SMT PG/MG J

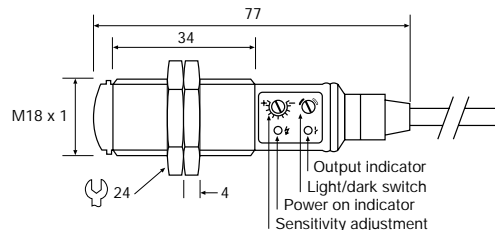

SMR/SMP/SMRR PG/MG 5

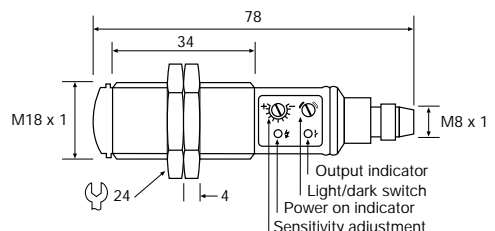

SMR/SMP/SMPF/SMRR PG/MG T3

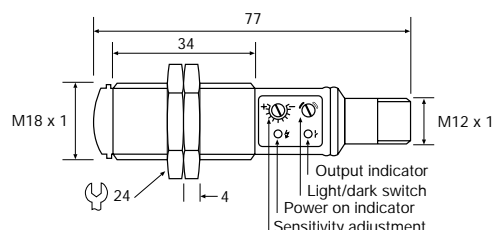

SMR PG/MG J

(Units in mm)

(Units in mm)

Telco reserves the right to change specifications without notice.



Description

- 1 relay output
- 115 V ac or 230 V ac supply voltage
- Power input and output indicators
- Adjustable on/off time delay
- Switch selectable light or dark function
- 11-pole DIN socket connection



The PP 00 is intended to be used in conjunction with a Spacemaster system, where there is a need for a relay output. This power pack series is supplied with a fixed 15 V dc output voltage, available with or without an adjustable 0-10 sec on/off time delay, light or dark function switch selectable.

| Technical Data | |
|-----------------------|---|
| Supply voltage | 115 V ac or 230 V ac |
| Voltage tolerance | +/- 15% |
| Power consumption | Max. 4 VA |
| Relay output | 1 open / 1 close 250 V ac / 3A, 120 V ac / 5A |
| Supply output voltage | 15 V |
| Supply output current | 175 mA |
| Power on indicator | Green LED |
| Input indicator | Green LED |
| Output indicator | Yellow LED |
| Housing material | Noryl |

| Environmental Data | |
|------------------------|--|
| Temperature, operation | -10 to +50 °C |
| Temperature, storage | -40 to +80 °C |
| Sealing class | IP 40 |
| Approvals | CE   |

| Available Types | | | | |
|-------------------------|--------------------|----------------|-----------------|-------------|
| Model | Connection | Supply Voltage | 115 V ac | 230 V ac |
| | | Output | Order Reference | |
| PP 00 A On/Off delay | 11-pole DIN socket | Relay | PP 00 A 501 | PP 00 A 500 |
| PP 00 B | | | PP 00 B 501 | PP 00 B 500 |

Note: 11-pole DIN socket to be ordered separately.

Wiring Diagrams

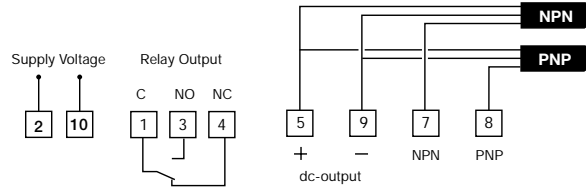

Dimensions and Descriptions

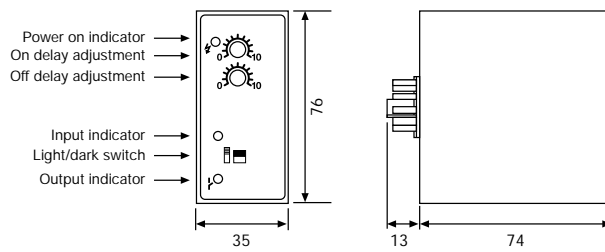

PP 00 A

(Units in mm)

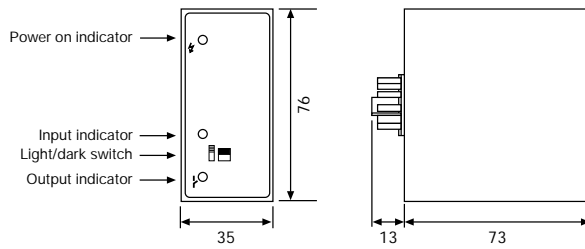

PP 00 B

(Units in mm)

Telco reserves the right to change specifications without notice.

Fibre Optics

Description

- Ideal for use in explosive areas
- Insensitive to electromagnetic and capacitive influence
- High temperature operation
- Various adaptor types
- Bifurcated or individual fibre construction



Technical Data

| | | |
|------------------------|-----------------|-----------------------------|
| Cover | | Silicone / Stainless Steel |
| Sheath material | | Stainless Steel |
| Sealing | | IP 67 |
| Strand diameter | | 50 μm |
| Bundle diameter | | 1,0; 2,3; 3,5; 4,0; 4,5 mm |
| Opening angle | | 67 ° |
| Adaptor Material | | Stainless Steel (V2A) |
| Bending Radius | | >5 x cover diameter |
| Temperature, Operation | Silicone | LLS / LYS = - 40 to +180 °C |
| | Stainless Steel | LLM / LYM = - 40 to +300 °C |

Available types for SMPF 7000 and 8000 Series

| Sensing End Tip Dimensions | Active Ø | Adaptor Type | Sensing Mode | Range | Cable Length | Order Reference | |
|--|----------|-------------------|--|-----------------|-----------------|-----------------|------------------------|
| | | | | | | Silicone Sleeve | Stainless Steel Sleeve |
| | 1,0 | C | Thru Beam | 10 cm | 60 cm | LLS 1300 | LLM 1300 |
| | | D | Diffuse Proximity | 4 mm | | LYS 1301 | LYM 1301 |
| | 2,3 | D | Diffuse Proximity | 4 mm | | LYS 1323 | LYM 1323 |
| | | C | Thru Beam | 60 cm | | LLS 1304 | LLM 1304 |
| | | D | Diffuse Proximity | 2,5 cm | | LYS 1305 | LYM 1305 |
| | | C | Thru Beam | 60 cm | | LLS 1302 | LLM 1302 |
| | D | Diffuse Proximity | 2,5 cm | LYS 1303 | | LYM 1303 | |
| | 3,5 | C | Thru Beam | 75 cm | | LLS 1310 | LLM 1310 |
| | | D | Diffuse Proximity | 6 cm | | LYS 1307 | LYM 1307 |
| | 1,0 | C | Thru Beam | 9 cm | | LLS 1312 | LLM 1312 |
| | | D | Diffuse Proximity | 3 mm | | LYS 1313 | LYM 1313 |
| | 2,3 | C | Thru Beam | 55 cm | | LLS 1314 | LLM 1314 |
| | | D | Diffuse Proximity | 2,5 cm | LYS 1315 | LYM 1315 | |
| | | C | Thru Beam | 45 cm | LLS 1318 | LLM 1318 | |
| | | D | Diffuse Proximity | 2,5 cm | LYS 1317 | LYM 1317 | |
| | 0,3 x 20 | C | Thru Beam | 50 cm | LLS 1362 | LLM 1362 | |
| | | D | Diffuse Proximity | 20 cm | LYS 1371 | LYM 1371 | |
| | | C | Thru Beam | 1,5 m | LLS 1370 | LLM 1370 | |
| Adaptor Type C – Individual Fibre Construction | | | Adaptor Type D – Bifurcated Fibre Construction | | | | |
| | | | | | | | |
| (Units in mm) | | | (Units in mm) | | | | |

Telco reserves the right to change specifications without notice.

Fibre Optics

Available types for Remote Photoelectric Systems

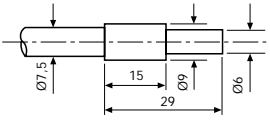
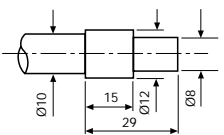
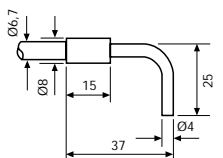
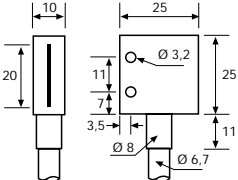
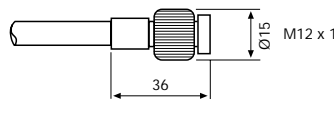
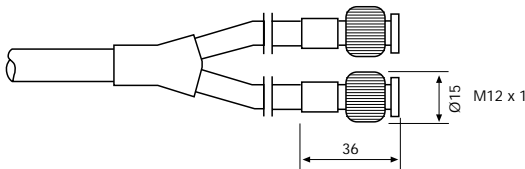
| Sensing End Tip Dimensions | Active Ø | Adaptor Type | Sensing Mode | Range | Cable Length | Order Reference | |
|--|----------|--------------|-------------------|---|--------------|-----------------|------------------------|
| | | | | | | Silicone Sleeve | Stainless Steel Sleeve |
|  V2A | 4,0 | A | Thru Beam | 8 m | 50 cm | LLS 1306 | LLM 1306 |
| | | | | 6 m | 1,5 m | LLS 1326 | LLM 1326 |
| | | | | 7 m | 1 m | LLS 1308 | LLM 1308 |
|  V2A | 4,5 | B | Diffuse Proximity | 70 cm | 50 cm | LYS 1309 | LYM 1309 |
| | | | | 60 cm | 1 m | LYS 1311 | LYM 1311 |
|  V2A | 2,3 | A | Thru Beam | 2.5 m | 1,5 m | LLS 1316 | LLM 1316 |
|  Aluminium | 0,3 x 20 | | | 1,4 m | 60 cm | LLS 1374 | LLM 1374 |
| | | | | 1,25 m | 1 m | LLS 1368 | LLM 1368 |
| Adaptor Type A – Individual Fibre Construction | | | | Adaptor Type B – Bifurcated Fibre Construction | | | |
|  (Units in mm) | | | |  (Units in mm) | | | |

Note: Range specified using PA 11 amplifier (page 13) in combination with Remote Sensor Series 100 (page 5).

Accessories

TR 10S

Screw clamp.
Size: Ø 10.
Material: Polycarbonate.

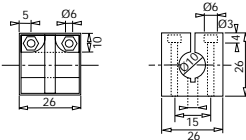

TRGM 18

Protective glass cover.
Size: M18.
Material: Stainless Steel.

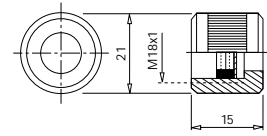

TR 10KB

Mounting clip.
Size: Ø 10.
Material: Polycarbonate.

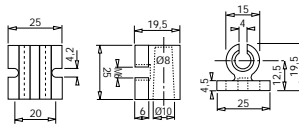

TRLM

Lens.
Size: M12.
Material: Stainless Steel.

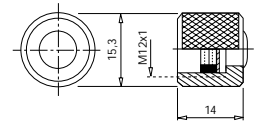

TR 6M

Screw clamp.
Size: Ø 6.
Material: Brass.

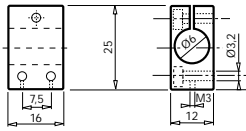

TRWM

90° Prism.
Size: M12.
Material: Stainless Steel.

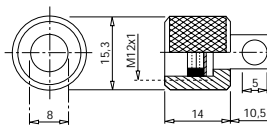

TR 8M

Screw clamp.
Size: Ø 8.
Material: Brass.

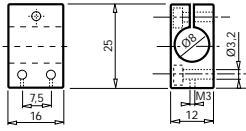

TRPG 11

Light shutter (tubus).
Size: Ø 10.
Material: Stainless Steel.

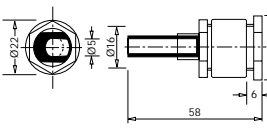

TR 10M

Screw clamp.
Size: Ø 10.
Material: Brass.

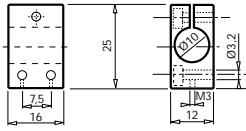

FA 18 SO

90° prism.
Size: M18.
Material: Polycarbonate.

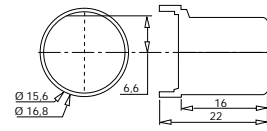

TR 12M

Screw clamp.
Size: Ø 12.
Material: Brass.

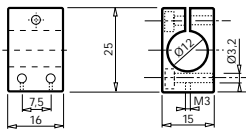

ILR 1

Rectangular reflector.
Size: 79 mm x 84 mm.

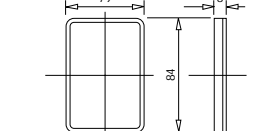

TRE

Light shutter with 1 mm hole.
Size: Ø 10.
Material: Polycarbonate.

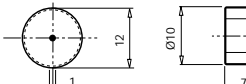

ILR 2

Rectangular reflector.
Size: 47 mm x 31 mm.

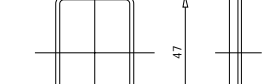

TREM 12

Light shutter with 1 mm hole.
Size: M12.
Material: Stainless Steel.

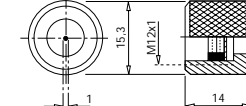

ILR 3

Circular reflector.
Size: 84 Ø.



TREGM 12

Light shutter with 1 mm hole with protective glass cover.
Size: M12.
Material: Stainless Steel

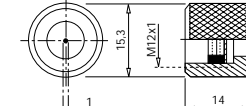

TR 11

Plug socket for PA photoelectric amplifiers and PP Power Packs

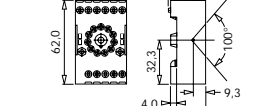

TRGM 12

Protective glass cover.
Size: M12.
Material: Stainless Steel.

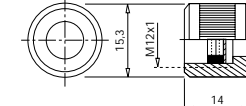



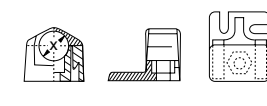

TRN

Mounting Bracket.
Sizes: Ø 10, Ø 12, Ø 18.
Material: Polycarbonate.

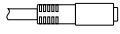

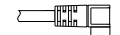
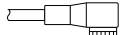
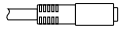
(Units in mm)

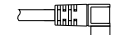
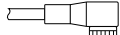
| Cables | | | | | | | | | | | |
|--------------------|---|-------------|---------------|----------|--------|-------------------------------|-------------------------------|-------------------------------|-------------------------------|-------------------------------|-------------------------------|
| Socket Type/Design | | Locking Nut | Sealing Class | Material | Length | Connector | | | | | |
| | | | | | | 3 pin, M8 | 4 pin, M8 | 4 pin, M12 | | | |
| | | | | | | Order reference | | | | | |
| Straight |  | No | IP 67 | PVC | 5m | ELKA K 3308 PVC5M S | ELKA K 4408 PVC5M S | — | | | |
| |  | Yes | | | | ELKA KV 3308 PVC5M S | ELKA KV 4408 PVC5M S | ELKA KV 4412 PVC5M S | | | |
| Right Angle |  | No | | | | ELWIKA K 3308 PVC5M R | ELWIKA K 4408 PVC5M R | — | | | |
| |  | Yes | | | | ELWIKA KV 3308 PVC5M R | ELWIKA KV 4408 PVC5M R | ELWIKA KV 4412 PVC5M R | | | |
| Straight |  | No | | | | IP 67 | PUR | 5m | ELKA K 3308 PUR5M S | ELKA K 4408 PUR5M S | — |
| |  | Yes | | | | | | | ELKA KV 3308 PUR5M S | ELKA KV 4408 PUR5M S | ELKA KV 4412 PUR5M S |
| Right Angle |  | No | | | | | | | ELWIKA K 3308 PUR5M R | ELWIKA K 4408 PUR5M R | — |
| |  | Yes | | | | | | | ELWIKA KV 3308 PUR5M R | ELWIKA KV 4408 PUR5M R | ELWIKA KV 4412 PUR5M R |

Telco reserves the right to change specifications without notice.

Capacity Load:

A load which is only or partially capacitive. An example is PLC inputs. They are often noise protected by a capacitor. Another example is a long pair of wires, where the capacity between the wires is significant.

Current Consumption:

The maximum current consumption for a unit when used at a specified voltage supply, or at the maximum rated voltage supply.

Dark Function:

When referring to photoelectric systems, dark function means that the output will be active (a relay operates) when no light is received from the transmitter.

Hysteresis:

An expression of the "inertness" of a system. For photoelectric systems the hysteresis is measured as a difference between the distance where sensors will see each other (L on) and the distance where they cannot see each other any more (L off). The hysteresis is normally expressed as a percentage of Lon.

Inductive Load Protection:

Protection of a transistor output stage against voltage peaks occurring when an inductive load (relay, solenoid, coil) is switched off.

Inverting of Relay Function:

When inverting, the function will be opposite i.e. if the relay was operated before, it will now be released.

Life Time:

The lifetime is defined as the time a unit can operate until the performance decreases to a specified level. The lifetime will normally depend on operation conditions such as temperature and humidity.

Light Function:

When referring to photoelectric systems, light function means that the output will be active (a relay operates) when light is received from the transmitter.

NPN output:

An output where the load is connected to a common positive supply rail.

Off delay:

The time delay between the absence (light mode operation) or presence (dark mode operation) of the IR beam and turning the output off.

On delay:

The time delay between the presence (light mode operation) or absence (dark mode operation) of the IR beam and turning the output on.

Output Short Circuit Protection:

Protection of a transistor output stage against damaging current flow, when the load is short circuited.

Output Load:

Normally meant as a pure resistive load.

PNP Output:

An output where the load is connected to a common negative supply rail.

Residual Voltage:

When used in conjunction with outputs, it means the residual voltage over the output circuit, when it is active. The residual voltage will normally depend on the load current.

Response Time:

The time delay between an event taking place and the registration being made. As an example, the time delay between a light beam in a photoelectric system is interrupted and the output relay has operated. It is often expressed in milliseconds (ms).

Reverse Polarity Protection:

Protection against wrong (reverse) connection to the supply wires.

Ripple:

Variation of the supply voltage with a frequency of 100 Hz (120 Hz). Expressed as a percentage of the actual supply voltage.

Start Up Delay:

The time delay between power switched on and the unit functioning. During this time the function can either be undefined or defined, depending on the construction.

Test input:

To test the function of the sensor, the transmitter can, for example, be switched off by a PLC in order to check whether the switching status changes at the relay or transistor output.

Operation Modes:

 **Thru Beam:** In thru beam sensing mode, the transmitted light is transmitted directly to the receiver by the transmitter, which is mounted on the opposite side. Thru beam is the most effective use of infrared light, enabling the highest level of excess gain for reliable sensing through dust, dirt, fog or other harsh environments.

 **Diffuse Proximity:** In diffuse proximity sensing mode, both the transmitter and receiver are located on the same side, in separate or within the same housing. The transmitted light is reflected back to the receiver by the surface of the detected object itself. The sensing range is very dependent on the reflectivity of the detected object. Darker objects absorb more light than lighter and more shiny objects.

 **Retro Reflective:** In retro reflective sensing mode, both the transmitter and receiver are located on the same side. The transmitted light is reflected back to the receiver by means of a reflector mounted directly on the opposite side.

 **Fibre optic:** Individual fibre optic cables are used in pairs for thru beam sensing mode. Bifurcated fibre optic cables combine both the transmitted and received light in the same assembly, and are used for diffuse proximity. Most fibre optic cables are able to withstand corrosive materials and/or where the operation temperature is too high for the sensor electronics themselves.

SpaceGuard™ – Light Curtain Systems

Description

SG 1

- 194 or 94 cross scanning beams
- 0-5 metre sensing range
- Automatic sensitivity adjustment
- 12-36 V dc supply voltage
- NPN or PNP transistor output
- Function via wire connection
- LED indication of system status
- Immune to interference from reflections and sunlight
- Test input
- Slim line detector housing (10x28 mm)
- Detector length, 2,00 m or 2,10 m

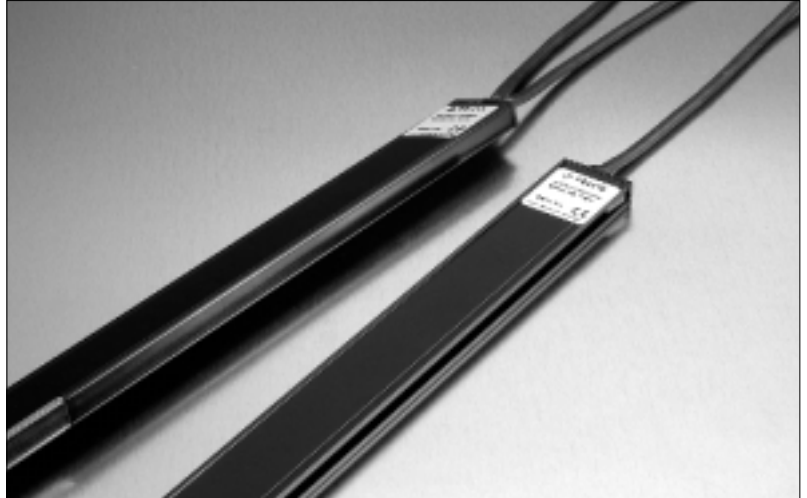

Description

SG 11

- 16 to 64 parallel light beams
- 0-5 metre sensing range
- Automatic or manual sensitivity adjustment
- 230 V ac, 115 V ac, 24 V ac or 24 V dc supply voltage
- Relay or NPN output
- Selectable time out
- LED indication of system status
- 10 000 lux extraneous light immunity
- Alarm and time out output
- Slim line (10x28 mm) or leading edge (37,5x13 mm) detector housing
- Detector length, 57 cm up to 2,10 m

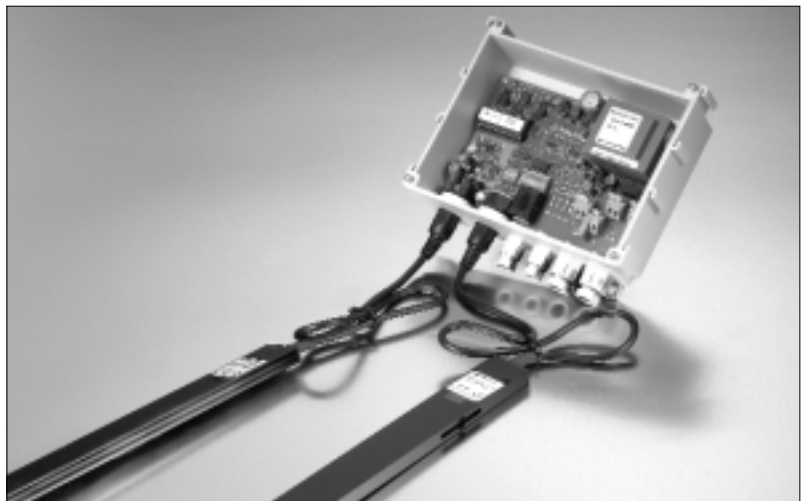

Telco can offer a complete range of light curtain systems.
Please ask for your free SpaceGuard™ literature.

Your local Telco Team

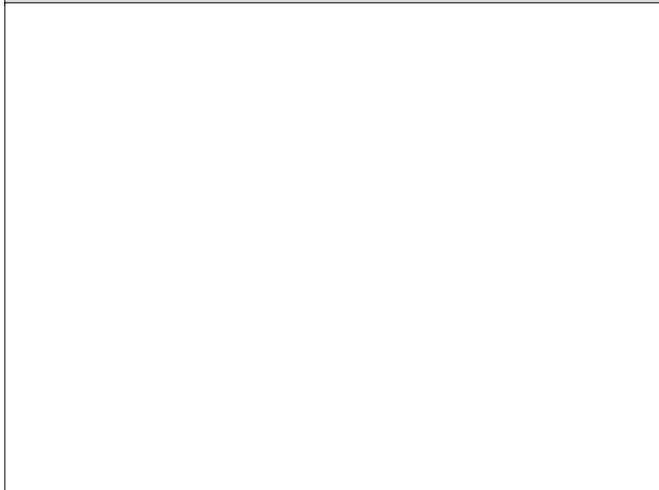

Telco's dealers named by Telco Teams, or Exclusive Importers, Business Partners or Distributors are not owned by Telco International Ltd. or any subsidiary of the holding companies behind Telco Production. Therefore, and as such, they have absolutely no authority to commit Telco International Ltd. or any subsidiary of the holding companies behind Telco Production to any pledge, contract or agreement, application in any form, by any means unless accepted beforehand by Telco International Ltd. or its subsidiaries.