



### Main applications

- Metal heat treating furnaces
- Vacuum furnaces with graphite elements
- High-temperature furnaces
- Boosters for glass lines
- Quick cutting on blow molding lines
- Machines and lines with unwanted current peaks and arcs
- "Fuse-free" solutions

### Main features

- Suitable for use in a wide range of applications including furnaces for heat-treatment, high temperature material-sintering processes, glass and ceramic production
- The integrated overcurrent fault protection provides complete heating process and system protection
- Designed for Super Kanthal™ and silicon carbide single or three-phase heating systems
- Operating current and voltage range up to 150A, 480V
- Configurable in all control firing modes including zero crossing, half-single cycle and phase angle
- Wide range of options to suit specific applications including transformer based heating systems
- Comprehensive connectivity options including fieldbus, Modbus RTU/TCP, Profibus, EtherCAT, Ethernet IP and CanOpen

### PROFILE

The Gefran GFW-Xtra power controller combines the functionality of a single, two or three phase solid-state power unit and controller with the benefits of the unique integrated overcurrent fault protection function.

The fault protection eliminates the need for extra-rapid fuses, reducing machine downtime and the cost of replacing fuse failures. It does so by instantaneously monitoring load current, cutting the power if the load reaches a pre-set threshold and isolating the power switching devices.

In applications susceptible to intermittent short-circuits and overloads, the Gefran Xtra power controller can be programmed to restore power automatically when the fault has cleared, preventing complete process shutdown and maintaining production.

Alternatively, power can be manually restored, locally or remotely.

A soft-start ramp is applied when the current is restored, to prevent system damage in the event that the fault is not effectively cleared.

The GFW-Xtra controller is compact, modular and optimised to control virtually any type of resistive heating system in a wide range of industrial applications.

Impressive functionality is assured by a comprehensive array of options that are configurable with intuitive, guided-set-up, PC-based Windows™ software.

GFW-Xtra always provides an RS485 serial

connection with Modbus RTU protocol to control currents, voltages, powers, load status, and device status from the supervisor terminal (HMI) or PLC.

A second (optional) communication port is offered that lets you choose from among the following Fieldbuses: Modbus RTU, Profibus DP, CanOpen, Modbus-TCP, Ethernet IP, EtherCAT.

## MODELS

### General features:

Nominal voltage: 480V  
Nominal current: 40, 60, 100 Arms @ 40°C  
in continuous service.

### Isolation HV

Rated isolation voltage input/output:  
4000Vac

## INPUTS

### Control analog input

Voltage: 5Vdc, 10Vdc  
Current: 0...20mA, 4...20mA  
Potentiometer: From 1KΩ to 10KΩ (auto-  
fed by 5V from GFW))

### Digital inputs (N. 3)

Range 5-30V max 7mA  
PWM input control: 0,03...100Hz  
(Configurable Features).

### PID inputs (Optional)

Configurable with  
TC input: type J, K, R, S, T, custom,  
PT100 RTD input  
Voltage input: 60 mV, 1V  
Current input: 0-20 mA, 4-20mA

### TC AUX inputs (Optional)

N. 4 configurable input:  
type TC J, K, R, S, T or 60 mVdc Linear  
input

### Voltage line range

Range: 90V... V\_nominal\_product  
Frequency: 50-60Hz

### Current load range:

Range: 0... 2\*I\_nominal\_product

### Key HB:

HB alarm calibration ON or reset memory  
alarms.

## OUTPUTS

### Power output, function mode:

**ZC** – Zero Crossing fixed cycle time  
**BF** – Burst Firing (Zero-crossing minimum  
optimize cycle time)  
**HSC** – Half Single Cycle (Zero-crossing  
corresponds to Burst Firing that manages  
single semi-cycles of conduction or stop  
cycles.)  
**PA** – Phase Angle

### Potentiometer power outputs:

5Vdc max 10mA

## ALARM OUTPUTS

n. 2 Relay N.A. (OUT9-10)  
n. 4 Optional outputs: Relay, Triac, Direct,  
Digital (OUT 5-6-7-8)

### Thermic Dissipation:

GFW models dissipate thermic power based on load current:  
 $P_{dissipation} = I_{load\_Arms} * 2.8V \text{ (W)}$

### Function Overcurrent Fault Protection

This function eliminates the need for an external extra-rapid fuse to protect the device. In case of load short-circuit, the internal device is instantaneously switched off and the alarm status is signalled.

### LED

N. 8 LEDs state indicator

### Condition of employment:

- Switching capacity: 5KA - 480V
- Inductance max system: 1000uH

### Modbus RS485 Serial (PORT1)

This lets you connect the GFW to a PLC or HMI via a simple RJ10 telephone wire by using an RS485 serial line with Modbus protocol.

The Baud-Rate is configurable from 1200 Baud to 19200 Baud.

A pair of rotary-switches lets you quickly assign the node address.

A dip-switch lets you internally insert the line termination resistance.

### FieldBus Serial PORT2 (optional)

An optional FieldBus card (PORT2) can

be inserted into the bottom of the device.

The following types are available:  
Modbus RTU, Profibus DP, CanOpen,  
Modbus-TCP, Ethernet IP, EtherCAT .

### GFW-OP Serial Keypad

A DB9 front panel connector lets you connect the GFW to the Gefran GFW-OP keypad (optional) for parameter configuration and device supervision.

### Installation notes:

- To assure maximum reliability, it is essential to install the unit correctly in the panel in order to guarantee adequate heat exchange between the heat sink and the room under natural convection conditions.
- Install the unit vertically (max 10° inclination from vertical axis).
- Vertical distance between unit and panel wall >100mm
- Applications with solid state power units must also include an automatic safety switch to cut out the load power line.

### Limits of use

- Dissipation of thermic power on the device with restraints on the ambient temperature of the installation.
- Equip the cabinet with an external air change or air-condition it, to put out dissipated power.
- Line transistor max. voltage and derivative limits, for which the solid state relay is equipped with inside safety devices (based on the models).
- Presence of load current dispersion (range 5-20mA depending on model) in absence of thyristor conduction due to internal RC protections.

## DERATING CURVES

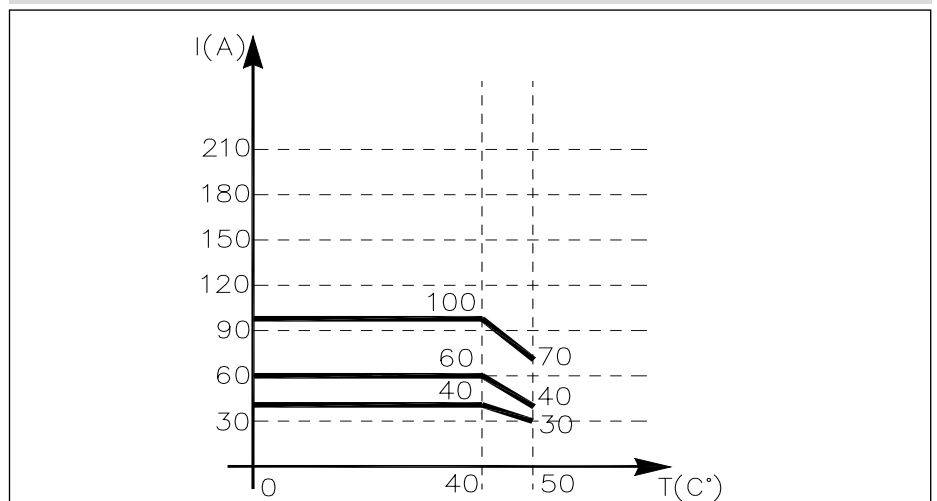

# DESCRIPTION OF CONNECTIONS

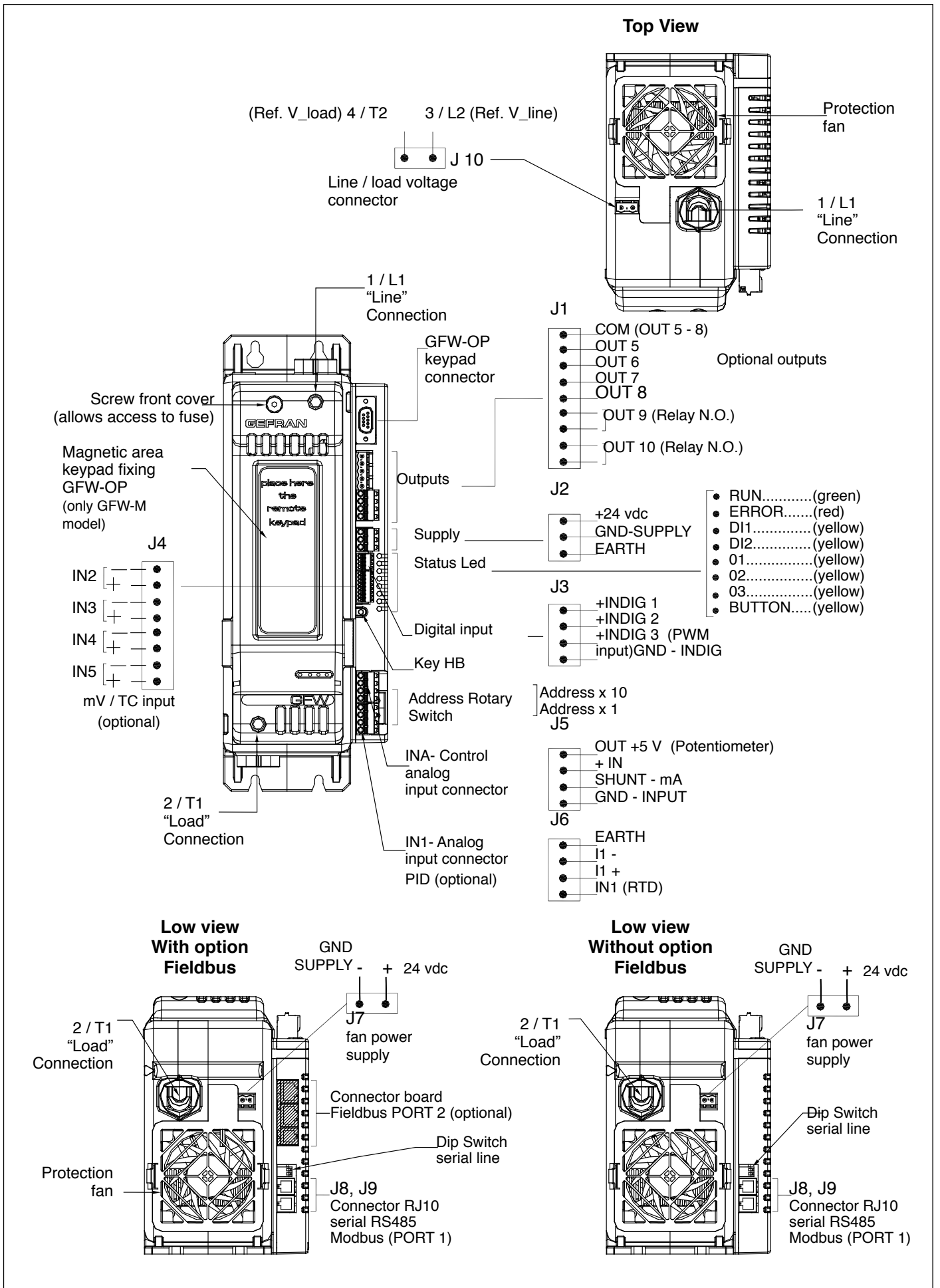

# FUNCTION MODE

## Trigger modes

The GFW provides the following power control modes:

- modulation via variation of phase angle: PA modality
- modulation via variation of number of conduction cycles with "zero crossing" trigger": ZC, BF, HSC modality.

### PA - Phase angle

This mode manages power on the load by modulating load phase angle

ex: if power to be transferred to the load is 100%,  $\theta = 180^\circ$

ex: if power to be transferred to the load is 50%,  $\theta = 90^\circ$

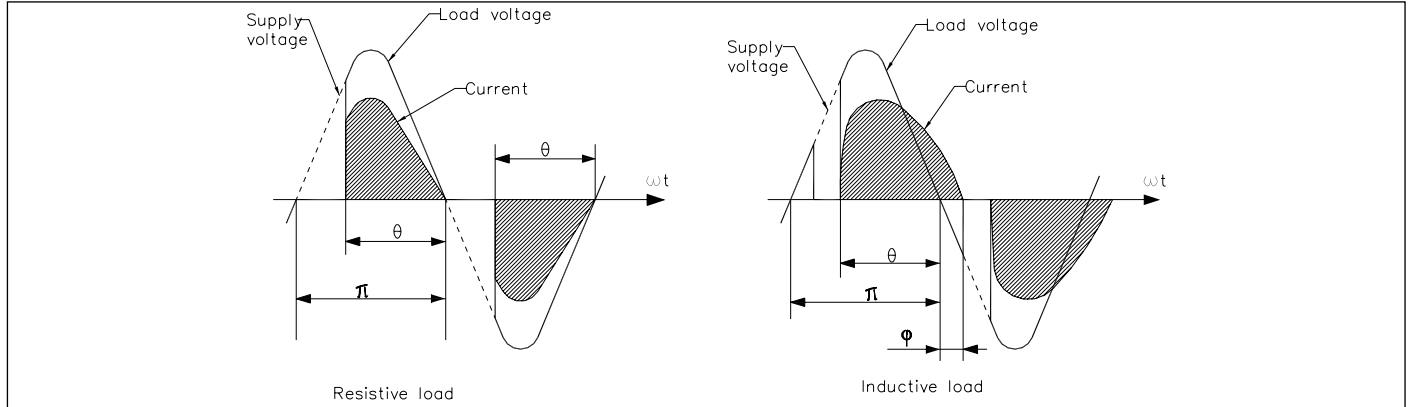

### Zero Crossing mode

This function eliminates EMC noise. This mode controls power on the load via a series of conduction ON and non conduction OFF cycles.

**ZC** - Zero Crossing constant cycle time ( $T_c \geq 1$  sec, settable from 1 to 200 sec) Cycle time is divided into a series of conduction and non conduction cycles in proportion to the power value to be transferred to the load.

For example, if  $T_c = 10$ sec, if the power value is 20% there is conduction for 2 sec (100 conduction cycles @ 50Hz) and non conduction for 8 sec (400 non conduction cycles @ 50Hz).

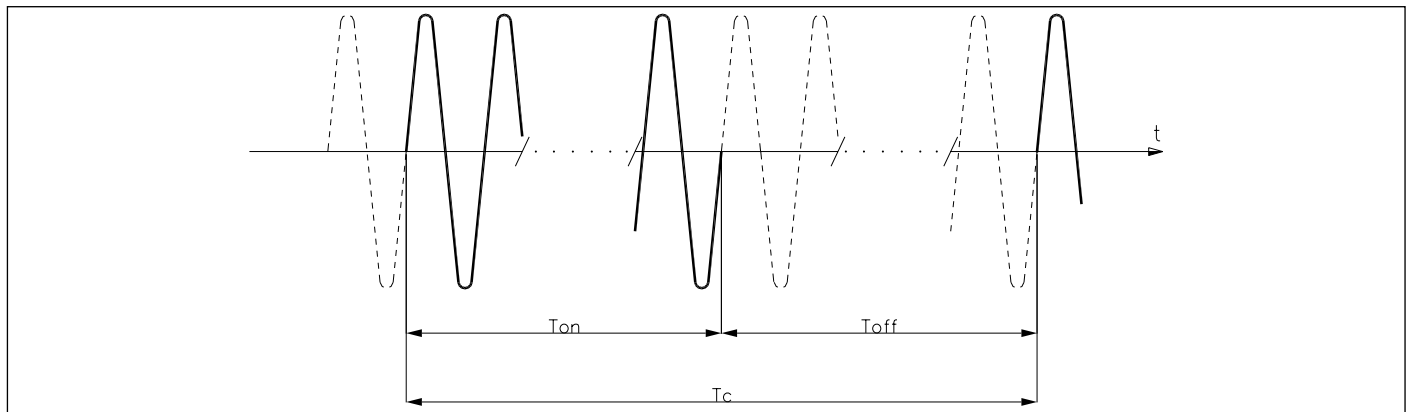

### BF - Burst Firing, Zero Crossing variable cycle time.

This mode controls power on the load via a series of conduction ON and non conduction OFF cycles.

The ratio of the number of ON cycles to OFF cycles is proportional to the power value to be supplied to the load.

The CT repeat period is kept to a minimum for each power value (whereas in ZC mode the period is always fixed and not optimized)

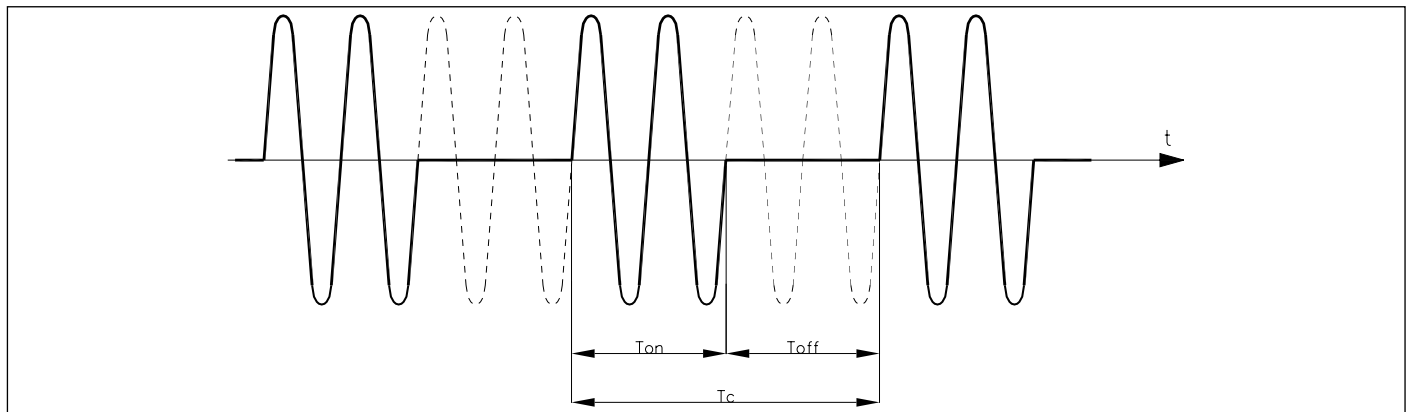

Example of operation in BF mode with power at 50%.

A parameter defines the minimum number of conduction cycles settable (from 1 to 10).

In the example, this parameter = 2.

# FUNCTION MODE

## HSC - Half single cycle

This mode corresponds to Burst Firing that manages Semi-cycles of on and off.

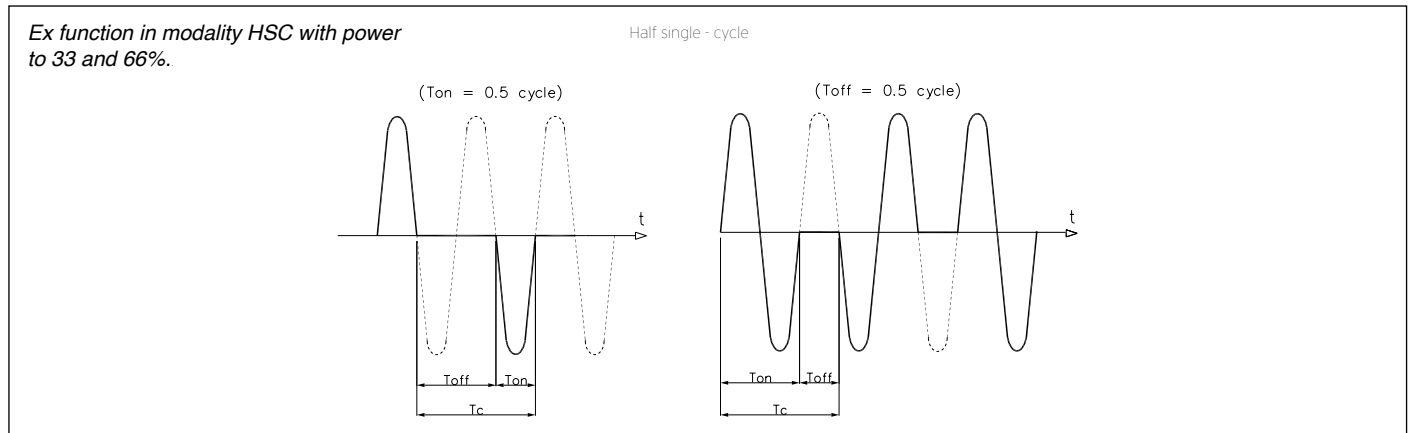

### Softstart or Ramp at power-on

This type of start can be enabled in either phase control or pulse train mode.

With phase control, the increment of firing angle  $\theta$  stops at the corresponding power value to be transferred to the load.

The control of maximum current spike can be enabled during the ramp phase (this is useful in case of short circuit on the load or loads with other temperature coefficients to automatically adjust the start time of the load).

The ramp is automatically re-enabled if the GFW remains off for a (settable) time.

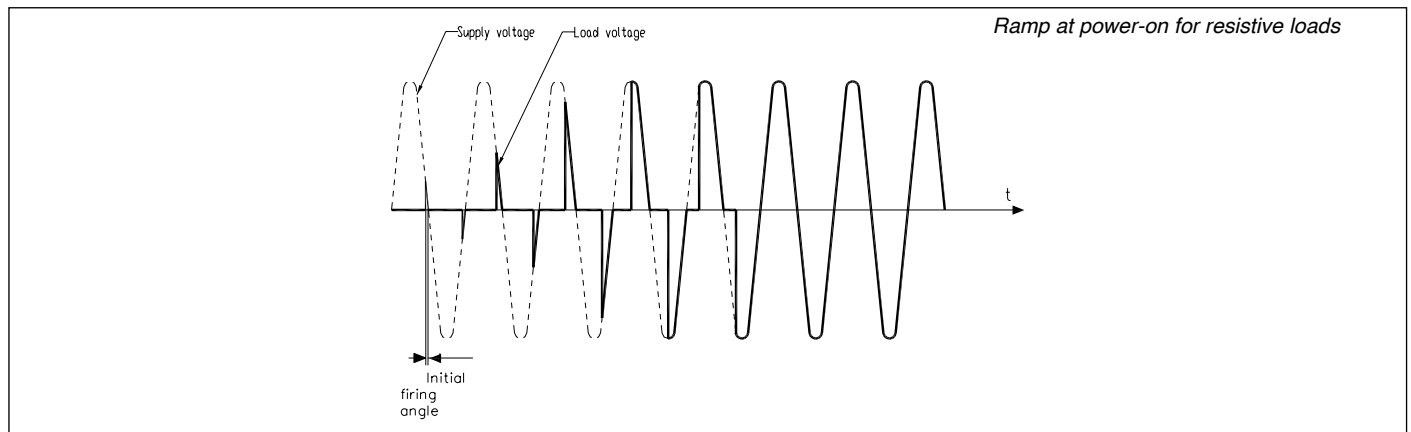

**DT** - "Delay triggering" of first cycle (only for control modes ZC, BF) Settable from  $0^\circ$  to  $90^\circ$ .

Useful for inductive loads (transformer primaries) to prevent current spike that could in certain cases trip the high-speed fuses that protect the SCRs.

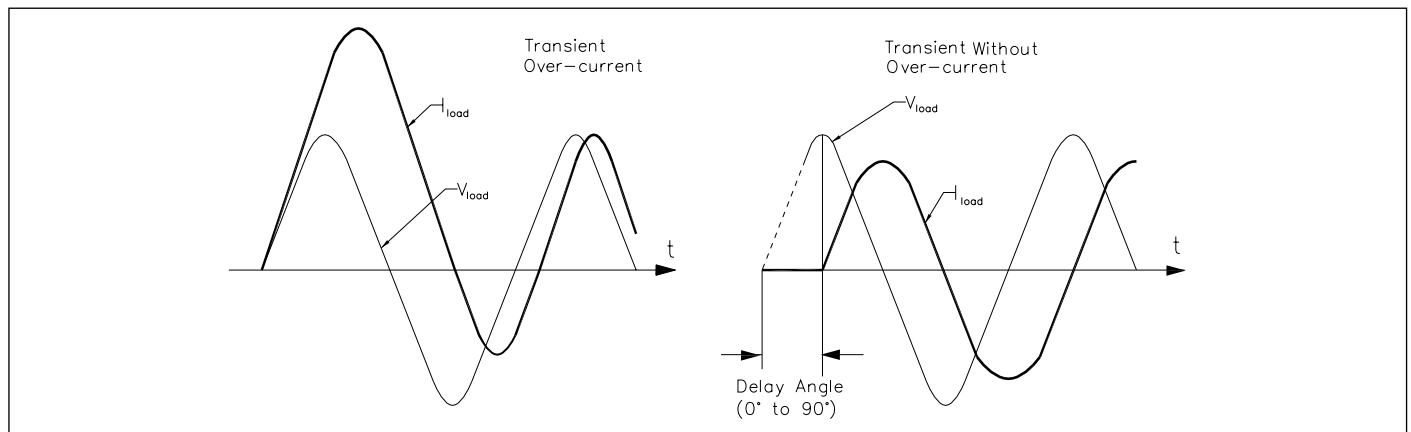

# DIMENSIONS

## GFW MASTER

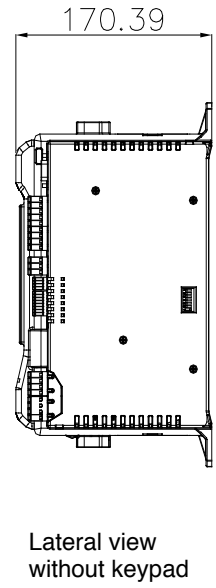
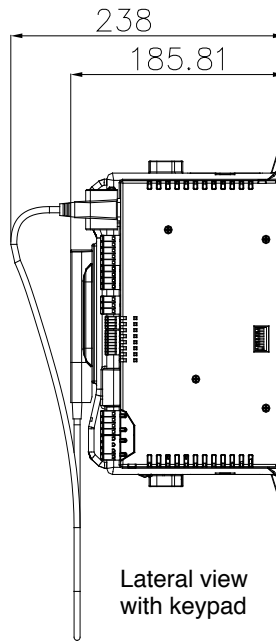
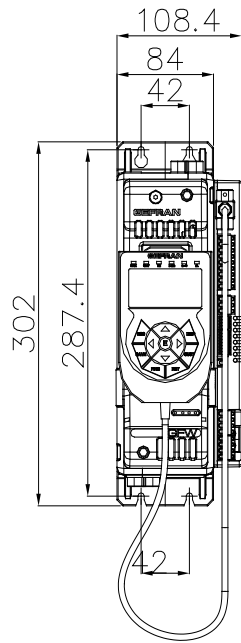

## GFW DUAL-PHASE (Master + 1 Expansion)

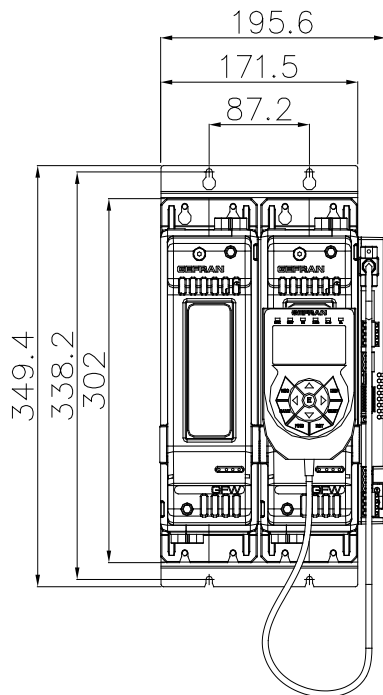

## GFW THREE-PHASE (Master + 2 Expansions)

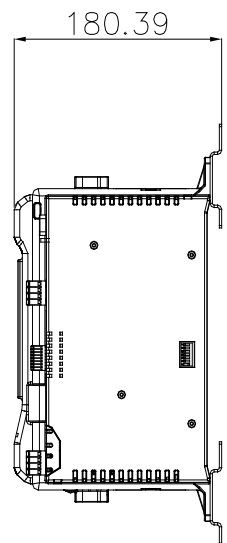
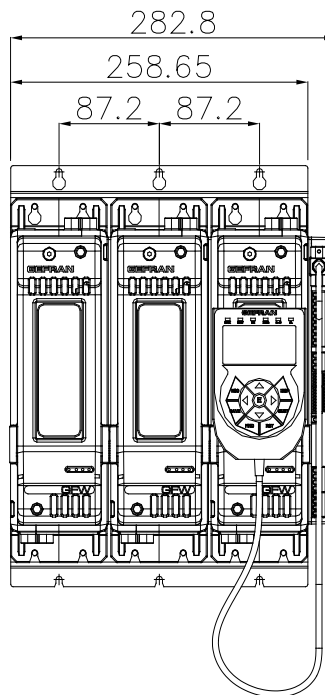

# TEMPLATE DIMENSIONS

## PANEL MOUNTING AND CUT-OUT DIMENSIONS

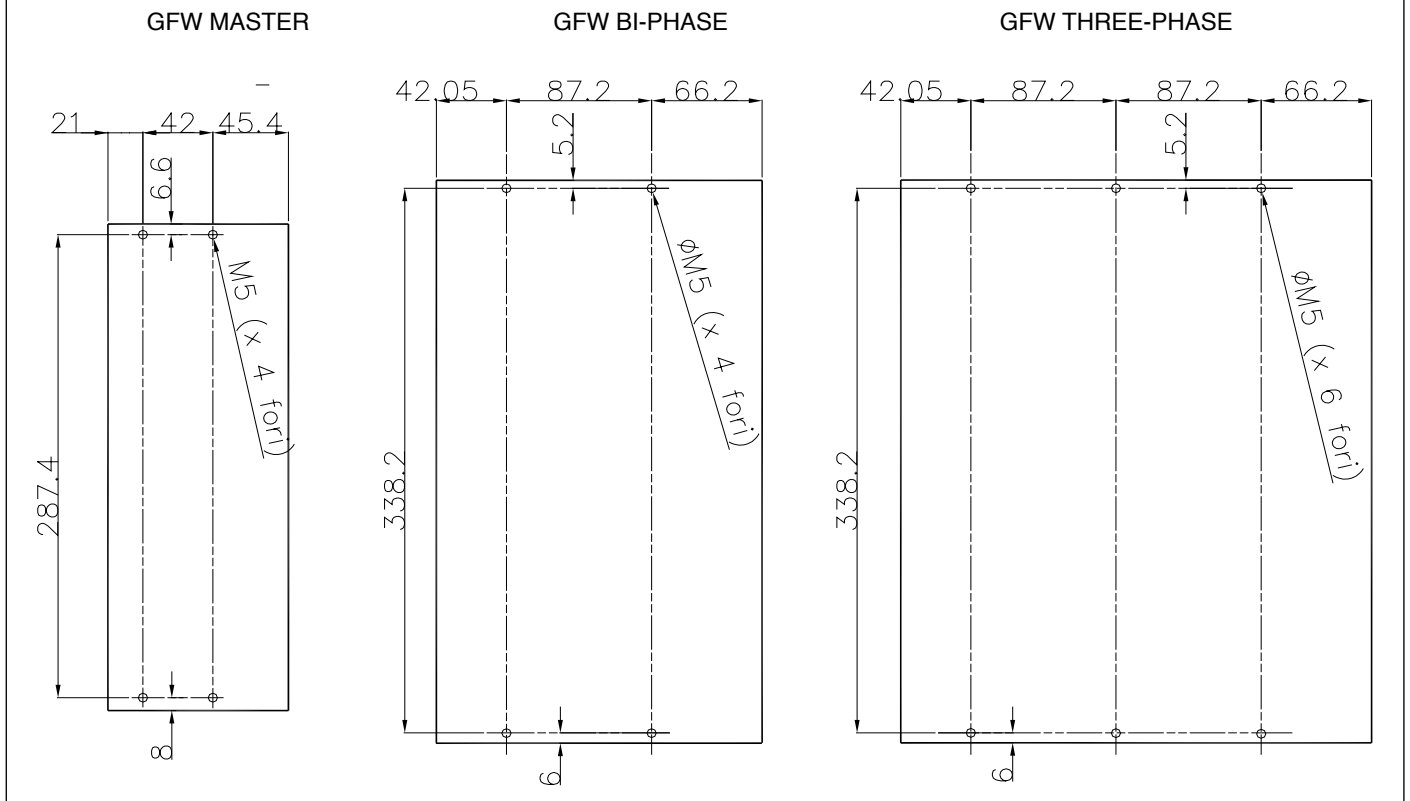

Fastening may be done with (5MA). All dimensions are expressed in mm.

## TECHNICAL DATA

### General features

Category of use: AC51, AC55b, AC56a

### Load type:

**AC51** resistive or low-inductance loads  
**AC55b** short-wave infrared lamp (SWIR)  
**AC56a** transformers (Request application check)

### Trigger mode:

**PA** - load control via adjustment of firing phase angle  
**ZC** - Zero Crossing with constant cycle time (settable in range 1-200sec)  
**BF** - Burst Firing with variable cycle time (GTT) optimized min.  
**HSC** - Half Single Cycle corresponds to Burst Firing that includes ON and OFF half-cycles.  
 Useful for reducing flicker with short-wave IR loads (applied only to calibrate each time you change feedback mode).

### Nominal voltage:

480Vac (max range 90-530Vac)  
 Nominal frequency: 50-60Hz

**Non-repetitive voltage:** 1200Vpk

### Control analog input:

Voltage: 0...5Vdc, 0...10Vdc (impedance > 100KΩ)  
 Current: 0...20mA, 4...20mA (impedance 125Ω)  
 Potentiometer: from 1KΩ to 10KΩ (auto-fed by 5V by GFW)

### Digital inputs

Range 5-30V max 7mA  
 PWM input control: 0,03...100Hz (only for INDIG 3)  
 (Configurable Features). 1500V isolation

### PID Input

Sampling time: 60msec  
 Accuracy: 0,2% FS ± 1 scale points 25°C.  
 Thermal drift: < 100ppm/°C scale points.  
 Type:  
 · Thermocouples ITS90: J, K, R, S, T, custom (IEC584-1, CEI EN 60584-1, 60584-2) Internal cold junction compensation with automatic compensation.  
 Selectable temperature range: °C/°F  
 · Thermoresistance: Pt100 DIN 43760  
 Max. resistance 20Ω  
 Selectable temperature range: °C/°F  
 · Voltage: range 0/12...60mV, Ri > 1MΩ  
 0/0,2...1V, Ri > 1MΩ custom linearization

at 32 sections

· Current: range 0/4...20mA, Ri = 50Ω  
 custom linearization at 32 sections

### TC AUX input

Sampling time: 480msec  
 Accuracy: 1% FS ± 1 scale point 25°C.  
 Tipo:  
 · Thermocouples ITS90: J, K, R, S, T, custom (IEC584-1, CEI EN 60584-1, 60584-2) Internal cold junction compensation with automatic compensation.  
 · Voltage: range 0/12...60mV, Ri > 1MΩ

### Voltage line range

Range: 90... V<sub>nominal\_product</sub>  
 Frequency: 50-60Hz  
 Accuracy: 1% f.s with neutral connected, 2% f.s. without neutral connected

### Voltage load range:

Accuracy: 1% f.s with load voltage measurement option (VLOAD option)  
 Accuracy: 2% f.s without option VLOAD

### Current load range:

measures RMS value  
 Accuracy: 2% f.s at room temperature of 25°C. Sampling time: 0.25msec

### **HB alarm output (optional)**

The HB function detects partial or total load interruption. The control measures load current by means of an internal device.

The current limit value is set via an automatic procedure activated with the HB button located near the upper connector.

The alarm output is obtained by means of outputs OUT 9-10 (or OUT 5-8).

### **RS485 Serial (PORT1)**

Double RJ10 connector

RTU RS485 Modbus Protocol

Baud-Rate configurable from 1200 Baud to 115000 Baud

Pair of rotary-switches for node address

Dip-switch for insertion of line termination resistance.

Isolation 1500V

### **Field bus (PORT2)**

Protocol:

Modbus RTU \_\_\_\_\_ 115Kbps

CANopen \_\_\_\_\_ 10K...1Mbps

Profibus DP \_\_\_\_\_ 9,6...12Mbps

Ethernet IP/Modbus TCP\_ 10/100Mbps

EtherCAT \_\_\_\_\_ 10/100Mbps

## **OUTPUTS**

### **Isolation HV**

Rated isolation voltage input/output: 4000Vac

### **Thermic Dissipation:**

GFW models dissipate thermic power based on load current:

$$P_{\text{dissipation}} = I_{\text{load\_Arms}} * 2.8V \quad (\text{W})$$

### **Function Overcurrent Fault Protection**

This function eliminates the need for an external extra-rapid fuse to protect the device. In case of load short-circuit, the internal device is instantaneously switched off and the alarm status is signaled.

### **LED**

N. 8 LEDs indicator:

RUN (green) RUN state of the CPU

ERROR (red) error

DI1 (yellow) DI1 digital input state

DI2 (yellow) DI2 digital input state

O1 (yellow) Out.1 main input state

O2 (yellow) Out.2 main input state

O3 (yellow) Out.3 main input state

BUTTON (yellow) State Key HB

### **Power supply**

24Vdc/+/-10% max.10VA

Isolation voltage: 1000V

### **Cooling Fan Power Supply**

24Vdc/±10% Input @ 25Vdc: max 500 mA

### **Ambient conditions**

Working temperature: 0-50°C (see the de-

rating curve)

Storage temperature:-20°C - +85°C

Max. relative humidity: 85% UR non-condensing

Max. installation altitude: 2000m above mean sea level

Installation requirements: Installation category II, pollution level 2, double isolation

Max. temperature of air surrounding device 40°C for temperature >40°C refer at derating curves - Device type: "UL Open Type"

Installation: panel with screws

Dimensions: see dimensions and installation

### **Weight**

GFW -M 40/60/100            2,2 Kg

GFW-E 40/60/100            2,0 kg



# ELECTRICAL CONNECTIONS

## POWER CONNECTIONS



### RECOMMENDED WIRE GAUGES



GFW CURRENT LEVEL	TERMINAL	WIRE GAUGE	TERMINAL TYPE	TIGHTENING / TOOL TORQUE
40A	1/L1, 2/T1	10 mm <sup>2</sup> 7 AWG	Wire stripped for 25 mm or with crimped pre-insulated terminal tube CEMBRE PKC1018	5 Nm / Flat-head screwdriver tip 1 x 5.5 mm
60A	1/L1, 2/T1	16 mm <sup>2</sup> 5 AWG	Wire stripped for 25 mm or with crimped pre-insulated terminal tube CEMBRE PKC1618	5 Nm / Flat-head screwdriver tip 1 x 5.5 mm
100A	1/L1, 2/T1,	35 mm <sup>2</sup> 2 AWG	Wire stripped for 25 mm or with crimped pre-insulated terminal tube CEMBRE PKC35025	5 Nm / Flat-head screwdriver tip 1 x 5.5 mm
---	3/L2 (Ref. Vline) 4/T2 (Ref. Vload)	0.25 ...2.5 mm <sup>2</sup> 23...14 AWG	Wire stripped for 8 mm or with tag terminal	0.5 ... 0.6 Nm / Flat-head screwdriver tip 0.6 x 3.5 mm

**Note:**

Cables must be copper "Stranded Wire" or "Compact-Stranded Wire" type with maximum operating temperature 60/75°C

### SIGNAL CABLES:

<b>J1: Output</b> <b>J2, J7: Power supply 24V</b> <b>J5, J6: Control inputs</b>		0,2 - 2,5mm <sup>2</sup>	24 - 14AWG
		0,25 - 2,5mm <sup>2</sup>	23 - 14AWG

<b>J3: Digital input</b> <b>J4: Input mV / TC AUX</b>		0,14 - 0,5mm <sup>2</sup>	28 - 20AWG
		0,25 - 0,5mm <sup>2</sup>	23 - 20AWG

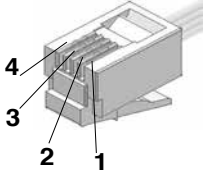
<b>J8, J9:</b> <b>RS 485</b>	Connector RJ10 4-4 pin	Nr. Pin	Name	Description	Note
			1	GND1 (**)	
		2	Tx/Rx+	Data reception/transmission (A+)	
		3	Tx/Rx-	Data reception/transmission (B-)	
		4	+V (reserved)		

**Cable type:** flat telephone cable for pin 4-4 conductor 28AWG

# ORDER CODE

**GFW -**  
Mono-phase

M [ ] 480 [ ] [ ] [ ] [ ] [ ] 2 [ ]

Model	
Master with CPU	M

Nominal Current	
40Ampere	40
60Ampere	60
100Ampere	100

PID Opt. Temperature	
Absent	0
TC/RTD/Linear input + PID	1

Auxiliaries Inputs	
Absent	0
4 TC/linear input (60mV)	1

Control options	
Current limit	1
Current limit and feedback V,I,P	2
Current limit and feedback V,I,P + Vload input	3

FIELDBUS Port 2 opz.	
0	Absent
M	Modbus RTU
P	Profibus DP
C	CANopen
E	Ethernet Modbus TCP
E1	Ethernet IP
E2	EtherCAT

Diagnostics Alarms Options	
0	Absente
1	Partial or total load failure alarm. (HB) + diagnostic alarms

Auxiliary Output opz.	
0	Absent
R	4 Relays
D	4 Digital outputs
C	4 Direct analogue outputs
T	4 Triac outputs

**Note:** All models have 480VAC nominal voltage

**GFW -**  
Mono-phase

E [ ] 480 0 0 [ ] 0 [ ] 2 0

Model	
Expansion module for bi-phase and three-phase	E

Nominal Current	
40Ampere	40
60Ampere	60
100Ampere	100

Diagnostics Alarms Options	
0	Absente
1	Partial or total load failure alarm. (HB) + diagnostic alarms

Control options	
1	Current limit
2	Current limit and feedback V,I,P
3	Current limit and feedback V,I,P + Vload input

**Note:** All models have 480VAC nominal voltage

# ORDER CODE

**GFW -**  
Bi-phase



Model	
1 module master (CPU) + 1 expansion module	2PH

Nominal Current	
40Ampere	40
60Ampere	60
100Ampere	100

PID Opt. Temperature	
Absent	0
TC/RTD/Linear input + PID	1

Auxiliaries Inputs	
Absent	0
4 TC/linear input (60mV)	1

Control options	
Current limit	1
Current limit and feedback V,I,P	2
Current limit and feedback V,I,P + Vload input	3

FIELDBUS Port 2 opz.	
0	Absent
M	Modbus RTU
P	Profibus DP
C	CANopen
E	Ethernet Modbus TCP
E1	Ethernet IP
E2	EtherCAT

Diagnostics Alarms Options	
0	Absente
1	Partial or total load failure alarm. (HB) + diagnostic alarms

Auxiliary Output opz.	
0	Absent
R	4 Relays
D	4 Digital outputs
C	4 Direct analogue outputs
T	4 Triac outputs

**Note:** All models have 480VAC nominal voltage

# ORDER CODE

**GFW -**  
Three-phase

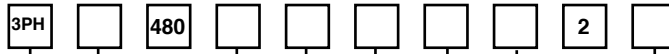

Model	
1 module master (CPU) + 2 expansion modules	<b>3PH</b>

Nominal Current	
40Ampere	40
60Ampere	60
100Ampere	100

PID Opt. Temperature	
Absent	0
TC/RTD/Linear input + PID	1

Auxiliaries Inputs	
Absent	0
4 TC/linear input (60mV)	1

Control options	
Current limit	1
Current limit and feedback V,I,P	2
Current limit and feedback V,I,P + Vload input	3

FIELDBUS Port 2 opz.	
0	Absent
M	Modbus RTU
P	Profibus DP
C	CANopen
E	Ethernet Modbus TCP
E1	Ethernet IP
E2	EtherCAT

Diagnostics Alarms Options	
0	Absente
1	Partial or total load failure alarm. (HB) + diagnostic alarms

Auxiliary Output opz.	
0	Absent
R	4 Relays
D	4 Digital outputs
C	4 Direct analogue outputs
T	4 Triac outputs

**Note:** All models have 480VAC nominal voltage

## ACCESSORIES

### CONFIGURATION KIT



Configuration/supervision kit for GFW by means of PC with USB (Windows environment).

Lets you read or write all of the parameters of a single GFW

A single software for all models

- Easy and rapid configuration
- Saving and management of parameter recipes
- On-line trend and saving of historical data

Component Kit:

- Connection cable PC USB <----> GFW RS485 port
- Serial line converter
- CD SW GF Express installation

#### ORDERING CODE

GF\_eXK-2-0-0.....Cod. F049095



The human/machine interface (HMI) is simple, intuitive, and very practical thanks to the optional GFW – OP programming keyboard.

Lets you read or write all of the parameters of a single GFW-M module.

Connected with 9-pin D-SUB connector and housed in the front panel of the GFW-M by means of a magnetic plate.

- Alphameric display: 5 lines x 21 characters.
- Keys to display variable and set parameters.
- Magnetic housing

#### ORDERING CODE

GFW - OP.....Cod. F051664

## • WARNINGS



**WARNING:** this symbol indicates danger.

#### Before installation, please read the following advices:

- follow the indications of the manual scrupulously when making the connections to the instrument.
- use a cable that is suitable for the ratings of voltage and current indicated in the technical specifications.
- if the instrument is used in applications where there is risk of injury to persons and damage to machines or materials, it is essential that it is used with an auxiliary alarm device.

It is advisable to verify frequently that the alarm device is functional even during the normal operation of the equipment.

- The instrument must NOT be used in environments where there could be the presence of dangerous atmospheres (inflammable or explosive).
- During continuous operation, the heatsink may reach 100°C and remain at a high temperature due to thermal inertia even after the device is switched off. Therefore, DO NOT touch the heat sink or the electrical wires.
- do not operate on the power circuit unless the main supply is disconnected.
- DO NOT open the cover if device is "ON"!

(use the holes in the cover for eventual re-calibration).

#### Installation:

- connect the device to the ground using the proper ground terminal.
- the power supply wiring must be kept separate from that of inputs and outputs of the instrument; always check that the supply voltage corresponds to that indicated on the instrument cover.
- Delete this line entirely..
- keep away from dust, humidity, corrosive gases and heat sources.
- The connection cable must be shorter than 3 meters if the current transformer is used.

**Maintenance:** Check the correct operation of the cooling fans at regular intervals; clean the ventilation air filters of the installation at regular intervals.

- Repairs must be performed only by specialized or appropriately trained personnel. Cut off power to the device before accessing internal parts.
- Do not clean the box with solvents derived from hydrocarbons (trichloroethylene, gasoline, etc.). Using such solvents will compromise the mechanical reliability of the device. To clean external plastic parts, use a clean cloth wet with ethyl alcohol or water.

**Technical service:** GEFTRAN has a technical service department. Defects caused by use not conforming to the instructions are excluded from the warranty.

GEFRAN spa reserves the right to make any kind of design or functional modification at any moment without prior notice

<b>CSA</b>	Conformity C/CSA/US CoFC no. 70002856
<b>UL</b>	Conformity C/UL/US file no. E243386 vol. 1 sect. 5
<b>CE</b>	This device conforms to European Union Directive 2004/108/CE e 2006/95/CE with reference to generic standards: EN 60947-4-3 (product) EN 61010-1 (safety)

**GEFRAN**

GEFRAN spa via Sebina, 74 - 25050 Provaglio d'Iseo (BS)  
Tel. 03098881 - fax 0309839063 - Internet: <http://www.gefran.com>

DTS\_GFW-Xtra\_07-2015\_ENG