

TYPES 8175 / 8170

ULTRASONIC LEVEL TRANSMITTER COMPACT AND SEPARATE VERSIONS



Instruction Manual

Ident. 427998P

1	INTRODUCTION	
1.1	Symbols Used	3
1.2	General Safety Instructions	3
2	QUICKSTART	
2.1	Installation	4
2.2	Programming	
2.2.1	Distance	5
2.2.2	Level	6
2.2.3	Volume	7
2.3	Testing	8
3	INSTALLATION	
3.1	General Installation guidelines	9
3.1.1	Beam cone diameter	9
3.2	Installation	10
3.2.1	Panel version installation	11
3.2.2	Wall mounted version installation	11
3.3	Electronic card identification	12
3.4	General Electrical Connection	
3.4.1	18-32 VDC Wiring via a cable plug	13
3.4.2	8175 Compact version, 18-32VDC or 115/230VAC	14
3.4.3	8175 Panel version, 18-32VDC	16
3.4.4	8175 Wall mounted version, 18-32VDC	17
3.5	Easy Link Connections	19-22
4	PROGRAMMING AND OPERATION	
4.1	Operating and Control Guide	23
4.2	Menu Guide	24
4.3	Main Menu	25
4.4	Calibration Menu	26
4.4.1	Language	27
4.4.2	Engineering Units	27-28
4.4.3	Filter Function	29-30
4.4.4	Gas Characteristics	31
4.4.5	Echo filtering	32-33
4.4.6	Teach-In procedures	
4.4.6.1	Teach-In for Level and distance	34
A	- 1 or 2 point Level or Distance Teach-In procedure	35
B	- Resetting of the Distance Reference point	36
4.4.6.2	TEACH-IN FOR VOLUME	37
C	- Input of tank dimensions	37
D	- Manual input of distances and associated volumes	39
E	- Volume teach-In procedure	41
4.4.7	Output Current	43
4.4.8	Relay (option)	44
4.4.8.1	Relay 1	45
4.4.8.2	Relay 2	46
4.5	Test Menu	47
4.5.1	Offset Compensation	48
4.5.2	Span Compensation	48
4.5.3	Temperature adjustment	49
4.5.4	Strength of return signal	49
4.5.5	Simulation of the level or temperature	50
4.5.6	Resetting of the transmitter	51
4.6	8175 Settings	52
4.6.1	Factory Settings	52
4.6.1	User Settings	52
5	MAINTENANCE	
5.1	Storing and cleaning of the sensor	53
5.2	Trouble shooting guide	53
6	ANNEX	
6.1	Specifications	55-56
6.2	Horizontal cylindrical tank value conversions	57
6.3	Dimensions	58-60
6.4	Design and Measuring Principle	61
6.5	Standard delivery	61
6.6	Type specification	62
6.7	Label type 8175	63
6.8	Spare parts list	63-64

1.1 SYMBOLS USED



Indicates information which must be followed. Failure to follow the information could endanger the user and affect the function of the device.



Indicates that the page contains general information.



Indicates a quickstart guide for quickly commissioning the transmitter.



Indicates that the page contains information about installation.



Indicates that the page contains information about configuration, programming and operation.



Indicates important information, tips and recommendations.



Indicates a worked example.



Indicates an action which has to be continued or reference to a relevant section.



Indicates information about repairs, service, maintenance and spare parts.

1.2 GENERAL SAFETY INSTRUCTIONS

Congratulations on purchasing our 8175 Digital Level Transmitter.



Before installing or using this product, please read this manual and any other relevant documentation to ensure you fully benefit from all the advantages the product can offer.

- Please verify that the product is complete and free from any damage. (see reference table section 6.7).
- It is the customer's responsibility to select an appropriate transmitter for the application, ensure the unit is installed correctly, and maintain all components.
- This product should only be installed or repaired by specialist staff using the correct tools.
- Please observe the relevant safety regulations throughout the operation, maintenance and repair of the product.
- Always ensure that the power supply is switched off and the pipes / tank do not contain any pressure before working on the device / system.
- If these instructions are ignored or the transmitter is not used according to the specifications, no liability will be accepted and the guarantee on the device and accessories will become invalid.

This section provides a comprehensive installation and operation guide which will assist with the commissioning of the 8175 Level Transmitter.

2.1

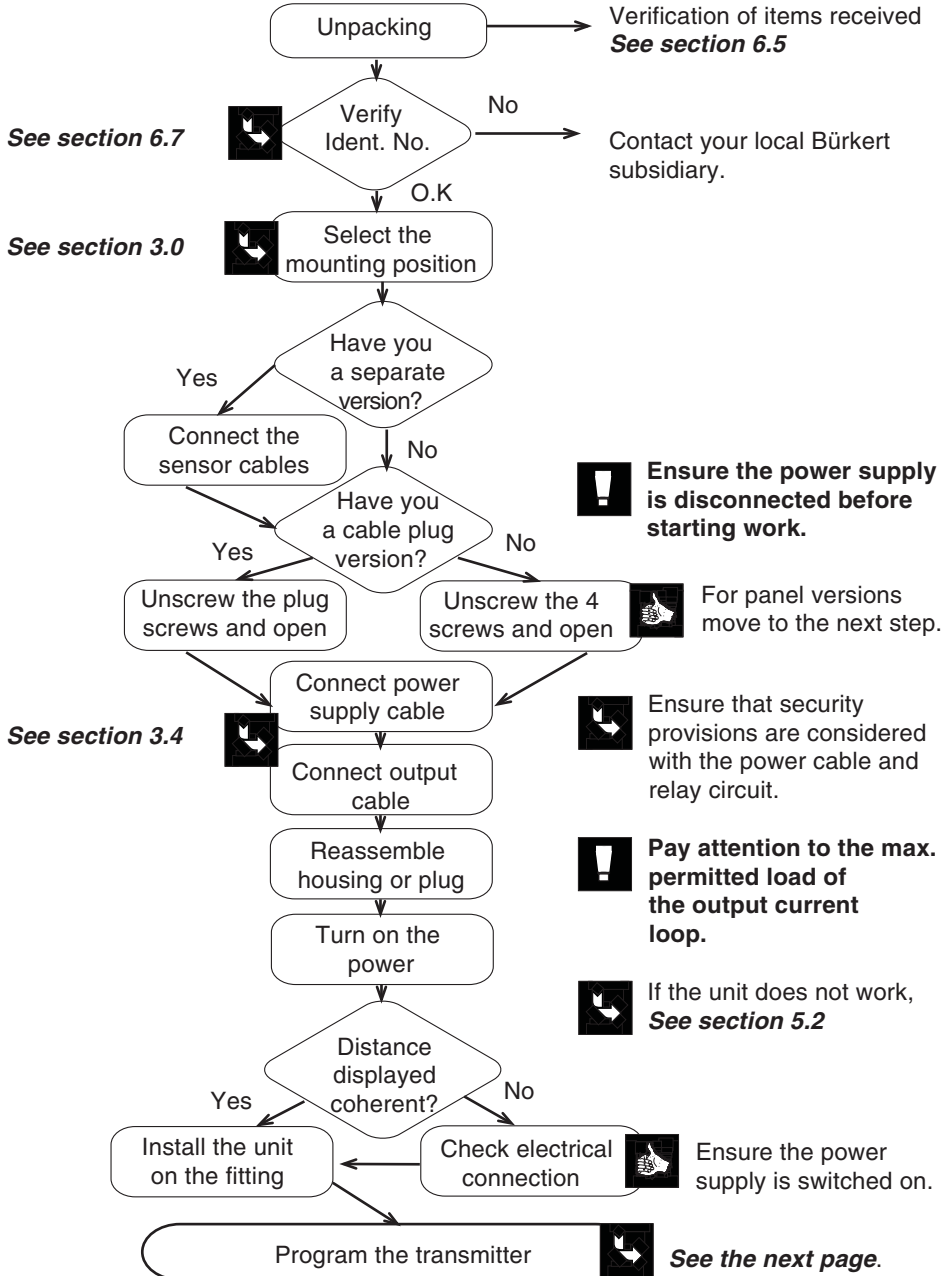

INSTALLATION



2.1 ENGLISH

2.2 PROGRAMMING

The electronics within the 8175 ultrasonic level transmitter allows the unit to be configured as either distance, level or volume depending on the application.



To access the **CALIBRATION MENU** simultaneously press   for 5 seconds.

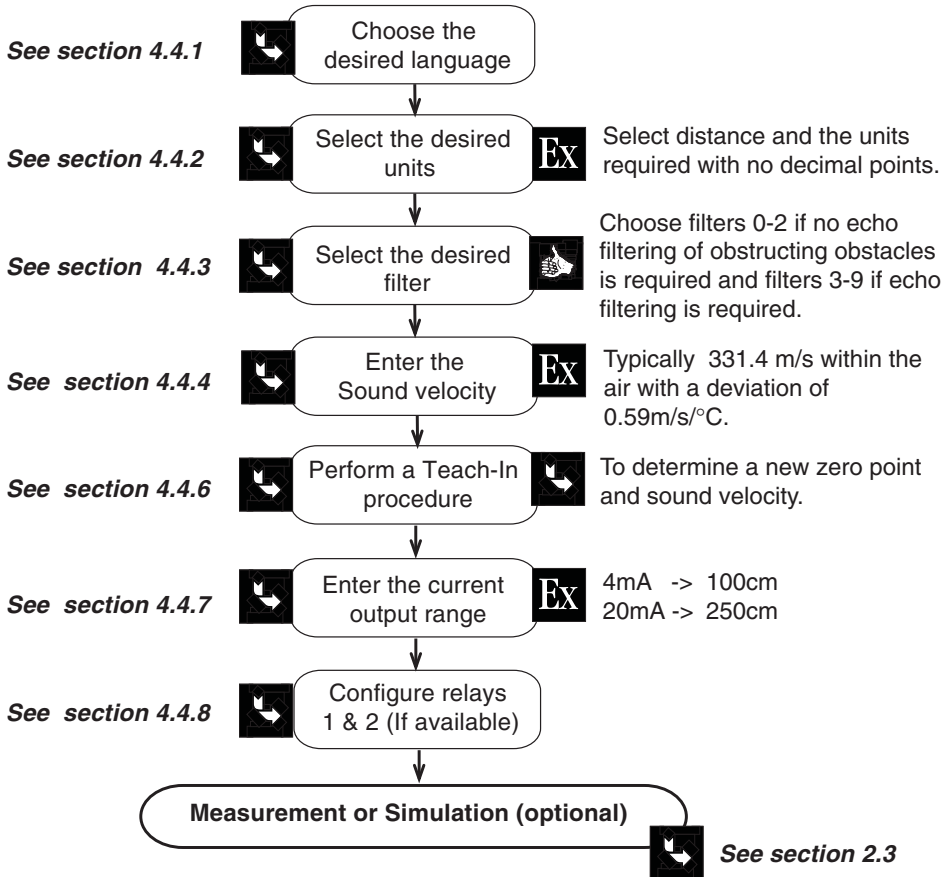

- The 'Enter' key can be locked to avoid accidental or unauthorised access - section 3.3.
- Reference can additionally be made to the menu guide - section 4.2.

2.2.1 PROGRAMMING - DISTANCE





To access the **CALIBRATION MENU** simultaneously press   for 5 seconds.

-  • The 'Enter' key can be locked to avoid accidental or unauthorised access - section 3.3.
- Reference can additionally be made to the menu guide - section 4.2.

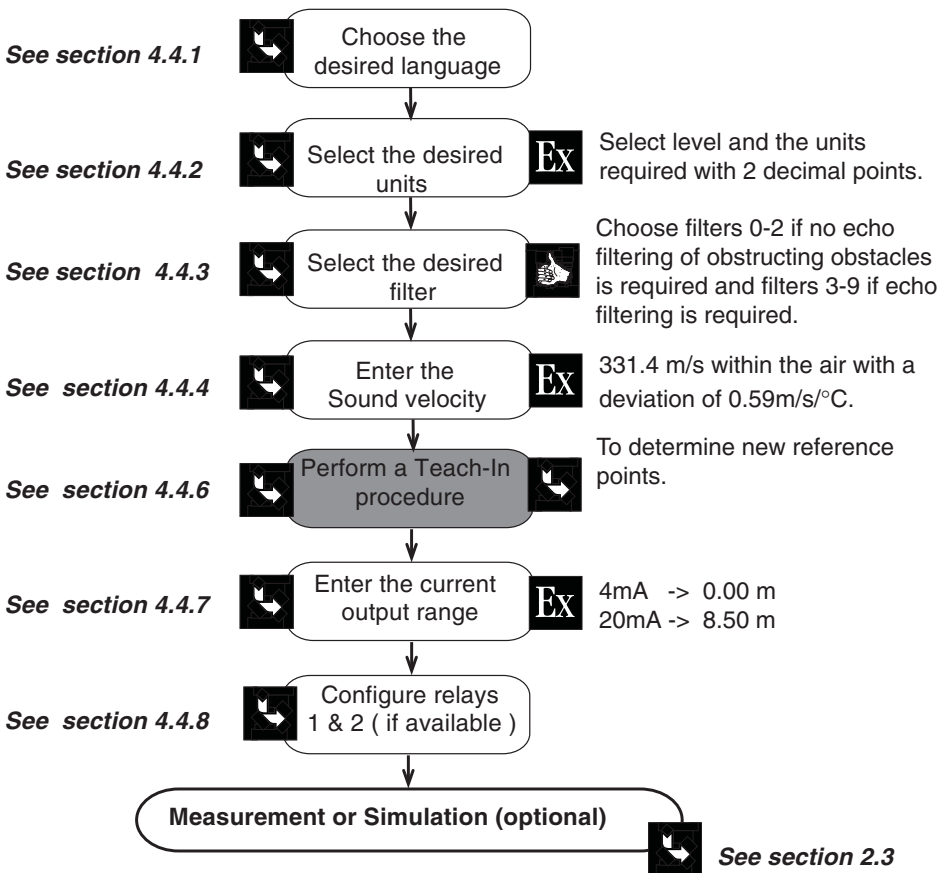
2.2.2 PROGRAMMING - LEVEL



 The actions which are highlighted in grey  must be fully completed for accurate measurement.

2.2.2 ENGLISH

To access the **CALIBRATION MENU** simultaneously press for 5 seconds.



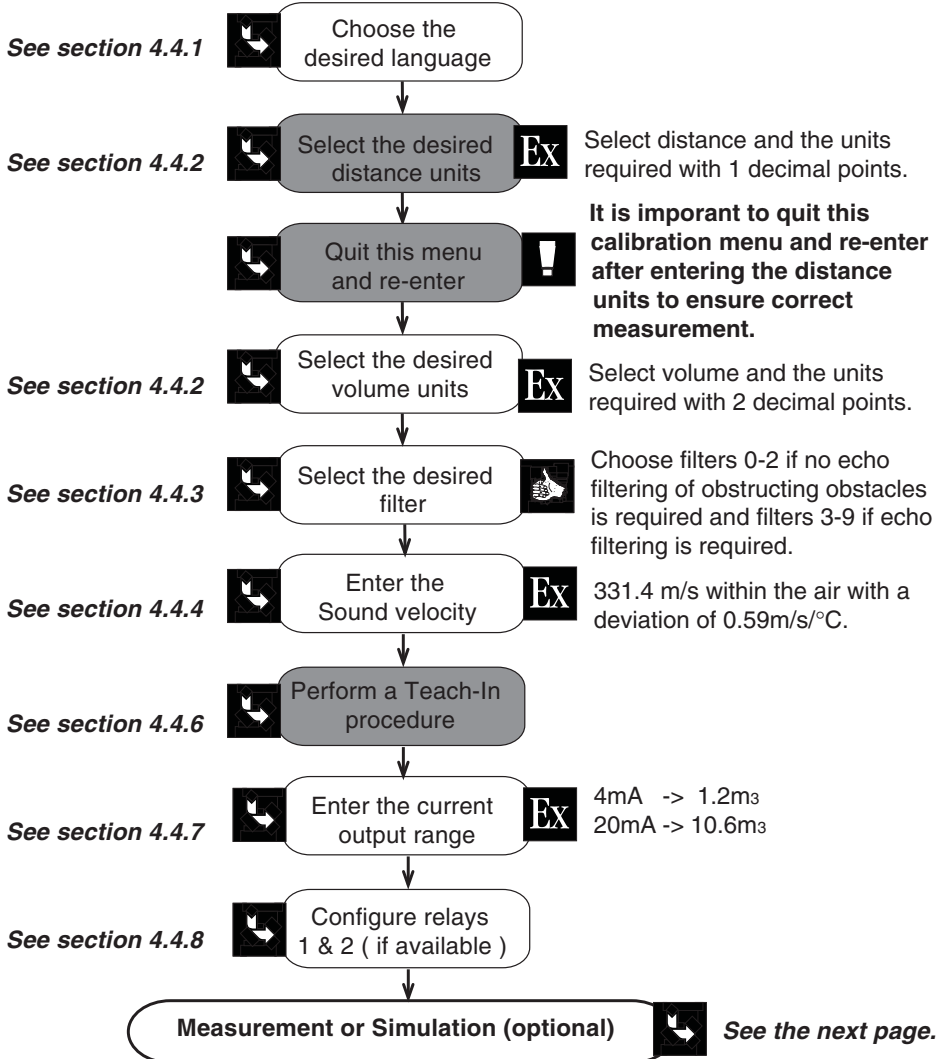

- The 'Enter' key can be locked to avoid accidental or unauthorised access - section 3.3.
- Reference can additionally be made to the menu guide - section 4.2.
- It is important to exit the menu calibration after entering the desired distance units and re-enter the menu to configure the volume units.

2.2.3 PROGRAMMING - VOLUME



The actions which are highlighted in grey must be fully completed for accurate measurement.

To access the **TEST MENU** simultaneously press    for 5 seconds.

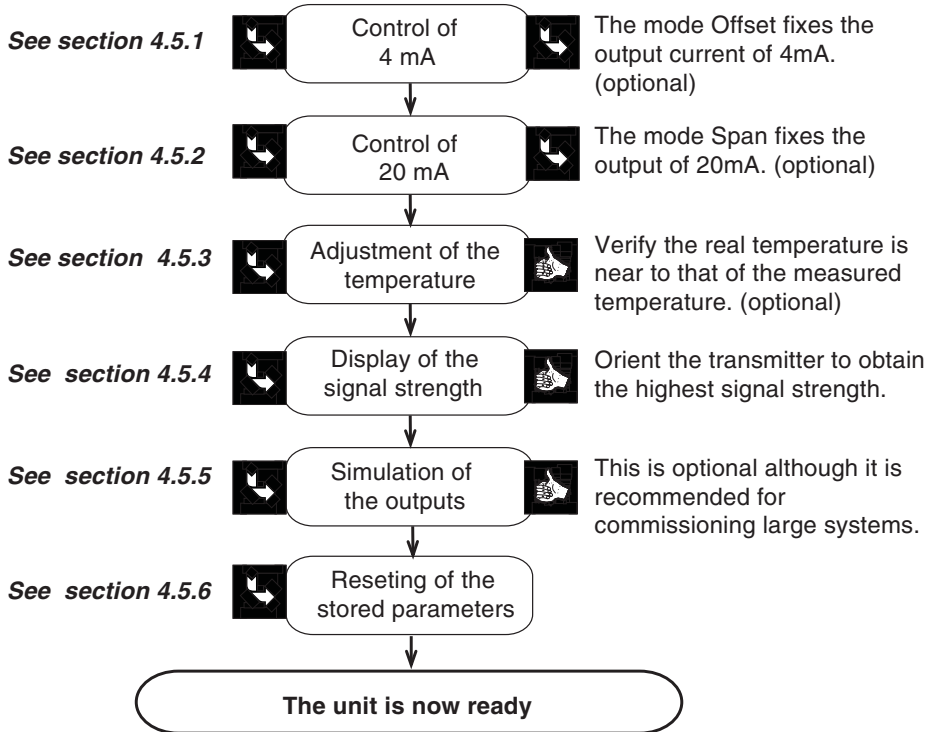
2.3**TESTING**



3.1 GENERAL INSTALLATION GUIDELINES

Prior to the installation of the 8175 ultrasonic level transmitter, a clear mounting location for the product must be determined.



- The level transmitter or sensor types 8175 / 8170 are designed for liquid level measurement. It is the user responsibility to test the functionality of the device for any other material such as powders, granuals etc.
- The 8175 ultrasonic level transmitter or sensor must be installed perpendicular to the process medium.
- Ensure a minimum distance of 30 cm between the level of the fluid and the sensor is respected.



The tank or vessel should be surveyed to locate potential obstructions which may interfere with the beam cone. Such obstructions may include: fill pipes and streams; mixers and agitators; tank side walls and rungs.

3.1.1 Beam cone diameter

The ultrasonic level transmitter type 8175 generates 8 pulses per second which is emitted from the base of the transducer. As the pulses leave the transmitter, they expand to an 8° beam angle until they are reflected back via the process medium. To determine the maximum diameter of the beam cone for the application select the maximum length (L) from the table below.

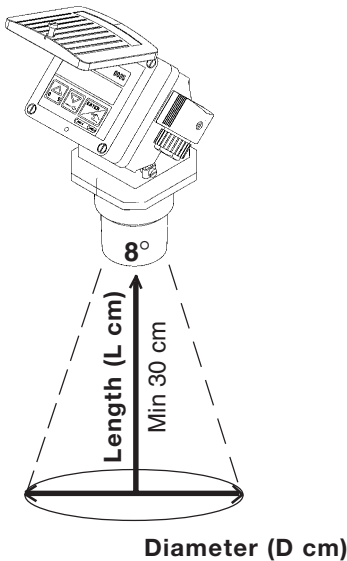

L	D	L	D	L	D
30	4	360	50	690	96
40	6	370	52	700	98
50	7	380	53	710	99
60	8	390	55	720	101
70	10	400	56	730	102
80	11	410	57	740	103
90	13	420	59	750	105
100	14	430	60	760	106
110	15	440	62	770	108
120	17	450	63	780	109
130	18	460	64	790	110
140	20	470	66	800	112
150	21	480	67	810	113
160	22	490	69	820	115
170	24	500	70	830	116
180	25	510	71	840	117
190	27	520	73	850	119
200	28	530	74	860	120
210	29	540	76	870	122
220	31	550	77	880	123
230	32	560	78	890	124
240	34	570	80	900	126
250	35	580	81	910	127
260	36	590	83	920	129
270	38	600	84	930	130
280	39	610	85	940	131
290	41	620	87	950	133
300	42	630	88	960	134
310	43	640	90	970	136
320	45	650	91	980	137
330	46	660	92	990	138
340	48	670	94	1000	140
350	49	680	95		

Fig. 3.1 Length and Diameter Relationship



INSTALLATION

3.2 INSTALLATION

The ultrasonic transmitter or sensor may be installed through the tank top via a standard G 2" (NPT) fitting or equivalent tapped flange according to the type of level transmitter.



Steps for successful installation:

- Before installation of the transmitter or sensor ensure that the fitting has been tested for leaks and the threads are not damaged or worn. If a damaged fitting is evident a new fitting should be installed.
- When installing the transmitter or sensor ensure that a proper seal is obtained between the fitting and transmitter via the use of an appropriate sealant or gasket.
- **When securing the transmitter or sensor to the fitting, only tighten by hand!**
- **Be careful not to overtighten the transmitter in the fitting.**



- **When securing the transmitter or sensor to the fitting, only tighten by hand!**
- **Be careful not to overtighten the transmitter in the fitting.**

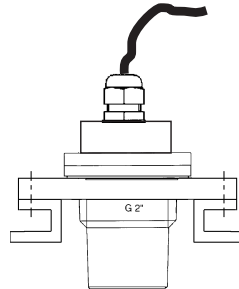
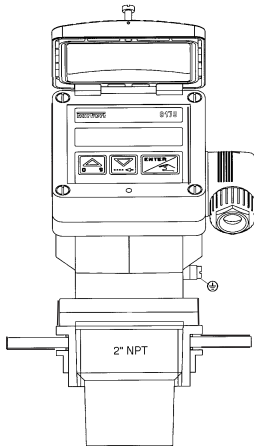

Shaft mounting

If the transmitter or sensor 8175 is installed on a shaft, it must not be higher than 400 mm for a diameter of 100 mm, or 250 mm for a diameter of 80 mm.

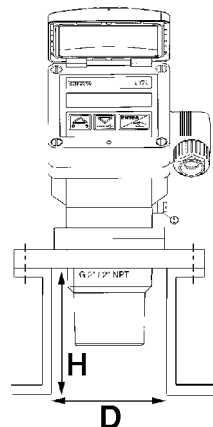

3.2 ENGLISH



3.2.1 PANEL VERSION INSTALLATION

For installation and insertion of the panel version follow the instructions on the enclosed delivery film and as follows:

1. Put gasket **2** on the cover **1** and place the complete unit in the cut-away panel.
2. Screw the spacer bolts **3** onto the panel fixing screws **4**.
3. Insert the cable clips **8**, to secure the various cables (power supply, outputs, sensor) of the transmitter, onto the plate **5**.
4. Fasten the plate **5** with the screws **7** onto the bolts **3**, tightening the locking washers **6**.

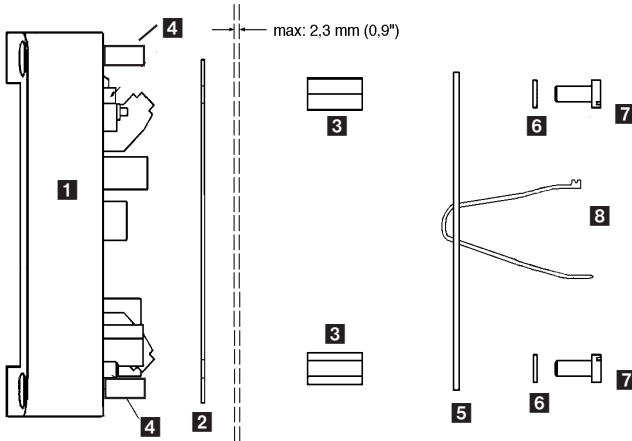

3.2.2 WALL-MOUNTED VERSION INSTALLATION

The level transmitter in a wall-mounted version has 4 fixing holes at the corners of the enclosure. Remove the white blanking strips and the cover to access to fixing holes **1**.

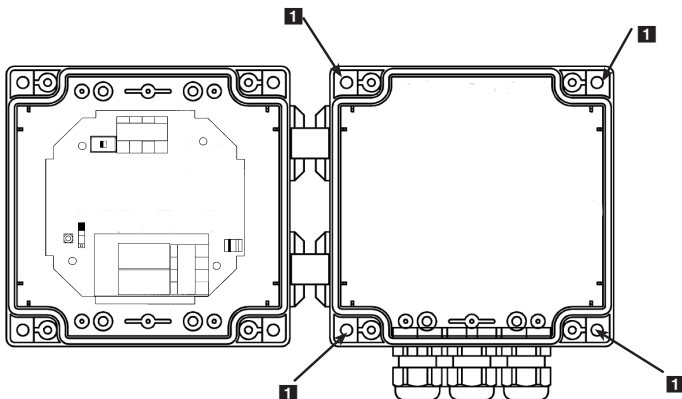



INSTALLATION

3.3 ELECTRONIC CARD IDENTIFICATION

This section allows easy identification of the features and electrical connections within the 8175 level transmitter depending on the version.

18-32VDC ELECTRONIC CARD

SW 2 - Sourcing or sinking configuration.

SW 1 - Locking of the 'Enter' key to avoid accidental or unauthorised access to the calibration and test menus.



Sensor Coax cable connection.

Terminal connections - Connection of power supply of 18-32VDC and 4-20mA output.

PT1000 connection.

Relay connections - Connection of relays 1 & 2 (optional).

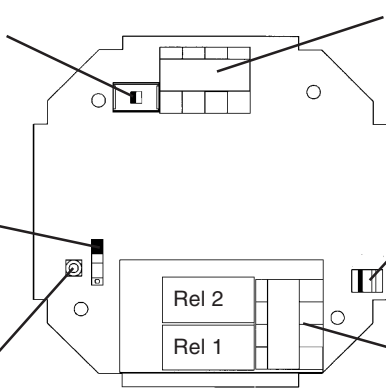



115 / 230VAC ELECTRONIC CARD (Compact version only)

Power supply switch - Changing the power supply from 115VAC to 230VAC.

Fuse - 315 mA T

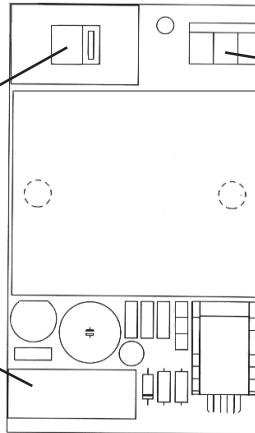
Terminal connections - Connection of power supply 115/230VAC.



- The Coax cable and PT1000 connections must be connected in all cases to ensure the device functions correctly.
- The  key can be locked to avoid accidental or unauthorised access by placing SW1 in the up position in the diagram above.



3.4 GENERAL ELECTRICAL CONNECTION

- Use cables with a temperature limit of 80°C minimum.
- For normal operating conditions the measuring signal can be transmitted by a simple cable of 0.75 mm² cross section.
- The line must not be installed in combination with carrying lines with a higher voltage or frequency.
- If a combined installation cannot be avoided, a minimum space of 30 cm (1 ft) or shielded cables should be adopted.
- When using shielded cables observe faultless grounding of the shield.
- For EMC purposes the earth must be connected via the earth lug on the side of the enclosure to a good local earthing point.
- The cable diameters for the PG versions must respect the following:
Compact: between 6-12mm and with a doubler 6mm
Wall mounted: between 4-8mm (PG's not used must be blanked off).



- In case of doubt, always use shielded cables.
- The power supply must be regulated - section 6.1.



- **Do not open and wire the transmitter with the power supply connected.**
- **It is obligatory to put security devices close to the transmitter, on :**
Power supply : 18-32VDC - 250mA fuse and interrupter
115/230VAC - 5A fuse and interrupter
Relay : 10A fuse max. and a circuit breaker (depending on the application).

ELECTRICAL WIRING 18-32 VDC

3.4.1 WIRING VIA A CABLE PLUG

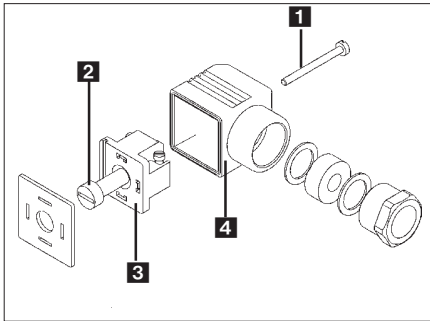

Fig. 3.3 Plug assembly

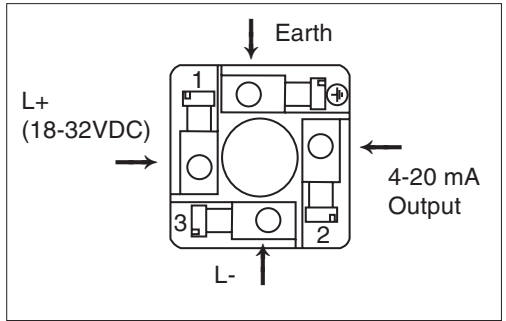

Fig. 3.4 Pin assignment

1. To open the connector remove screws **1** and **2** including the plastic ring (Fig. 3.3).
2. Remove the internal part **3** from the external casing **4** with a screwdriver blade.
3. Connect the transmitter according to the pin assignment in Fig. 3.4
4. When re-assembling, the internal part can be rotated in 90° steps to a desired position before inserting back into the casing **4**.



INSTALLATION

3.4.2 8175 COMPACT VERSION, 18-32 VDC, WITH PG 13.5

WIRING

Remove the cover via the screws on the front display and pull the cable through the PG 13.5 and wire according to one of the pin assignment diagrams below. The electronics within the 8175 allows a sourcing or sinking PLC to be connected. Position A (Fig 3.5) provides a sourcing configuration and Position B (Fig 3.6) a sinking configuration.

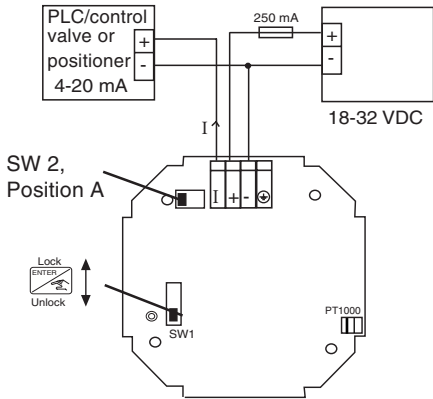

Fig. 3.5 Pin assignment, Position A

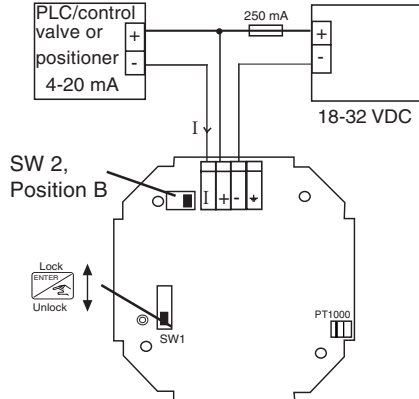

Fig. 3.6 Pin assignment, Position B

8175 COMPACT VERSION, RELAY CONNECTION

The electrical wiring of this model is possible via the use of 2 cable glands. Remove the cover via the screws on the front display and pull the cables through the PG 13.5 and wire according to pin assignment diagram below (Fig. 3.7).

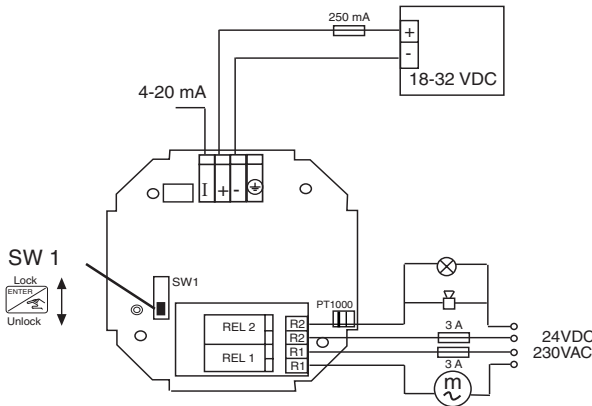

Fig. 3.7 Pin assignment for relays



- The device can be easily connected to a PLC independently of the respective version.
- The 'Enter' key can be locked by placing the SW 1 switch into the up position to avoid accidental or unauthorised access.



8175 COMPACT VERSION, 115/230 VAC

WIRING

Remove the cover via the screws on the front display and pull the cable through the PG 13.5 and wire according to one of the pin assignment diagrams below. The electronics within the 8175 allows a sourcing or sinking PLC to be connected. Position A (Fig 3.5) provides a sourcing configuration and Position B (Fig 3.6) a sinking configuration.



- **Do not open and wire the transmitter with the power supply connected.**
- **Ensure that the power supply switch is selected for the appropriate voltage 115VAC or 230 VAC.**



The connection for relays 1 and 2 are identical to that of the 18-32VDC on the previous page.

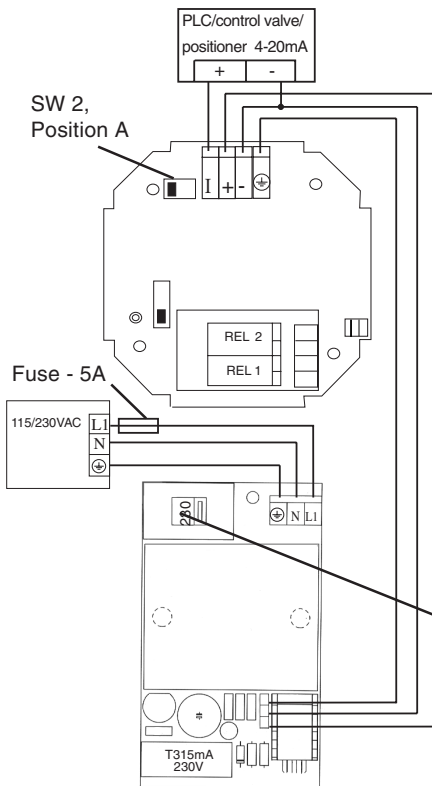

Fig. 3.8 Pin assignment, Position A

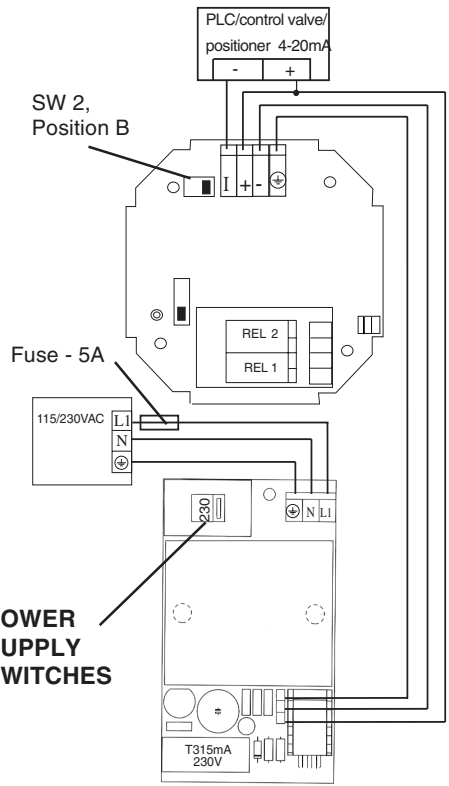

Fig. 3.9 Pin assignment, Position B



INSTALLATION

3.4.3 8175 PANEL VERSION 18-32VDC

CONNECTION OF THE 8170 SENSOR

- Pass the cable through the wall / panel and use the PG 9 to secure the cable.
- Connect the coax and PT1000 temperature cables shown in the diagram below.
- Secure all the cables onto the protection plate as indicated via the 2 plastic ties provided.

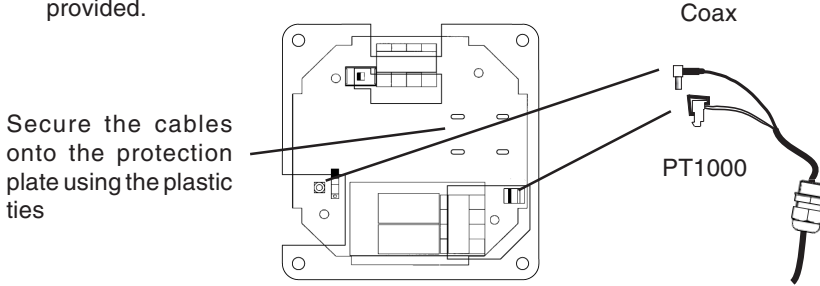

Fig. 3.10 Panel cable connections

8175 PANEL VERSION 18-32VDC, WIRING

Open the cabinet/cupboard and wire according to the pin assignment diagrams below. The electronics within the 8175 allows a sourcing or sinking PLC to be connected. Position A (Fig 3.11) provides a sourcing configuration and Position B (Fig 3.12) a sinking configuration.

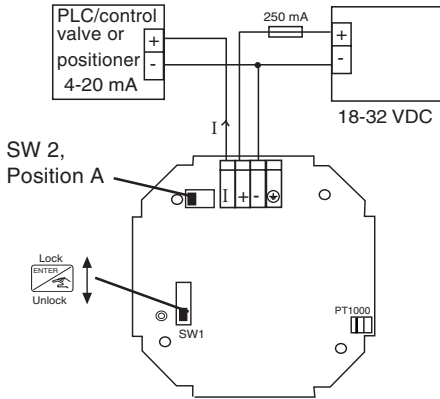

Fig. 3.11 Pin assignment, Position A

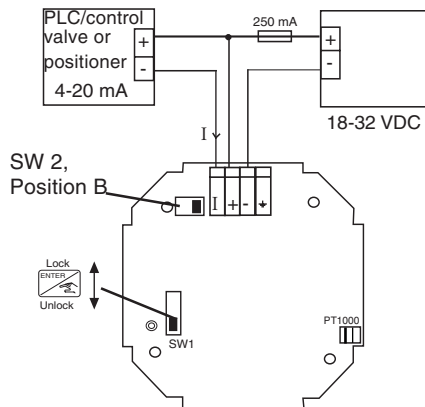

Fig. 3.12 Pin assignment, Position B



8175 PANEL VERSION, RELAY CONNECTION

The relay version is connected as follows :

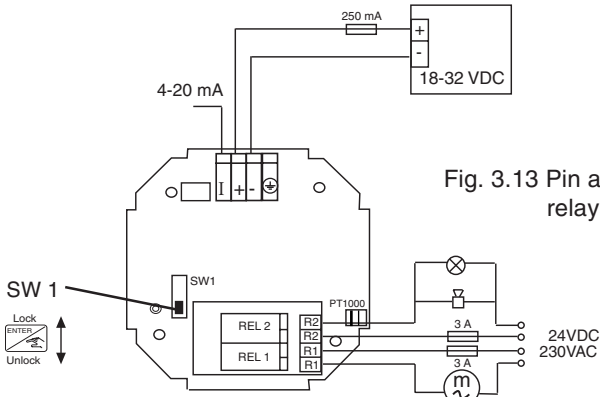

Fig. 3.13 Pin assignment for relays



- The device can be easily connected to a PLC independently of the respective version.
- The 'Enter' key can be locked by placing the SW 1 switch into the up position to avoid accidental or unauthorized access.

3.4.4 8175 WALL MOUNTED VERSION 18-32VDC

CONNECTION OF THE 8170 SENSOR

- Remove the cover via the screws on the front display and remove the PG 9 as indicated passing the cable through the hole.
- Secure the PG 9 supplied on the cable to the box using the plastic nut and secure the cable.
- Connect the coax and PT1000 temperature cables as shown in the diagram below.

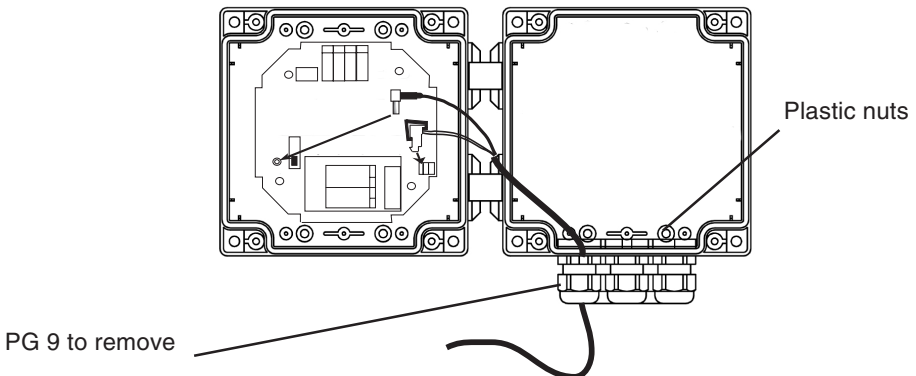

Fig. 3.14 Wall cable connections



INSTALLATION

8175 WALL MOUNTED VERSION, 18-32 VDC; WIRING

Remove the cover via the screws on the front display and pull the cable through the PG 9 and wire according to one of the pin assignment diagrams below.

The electronics within the 8175 allows a sourcing or sinking PLC to be connected. Position A (Fig 3.15) provides a sourcing configuration and Position B (Fig 3.16) a sinking configuration.

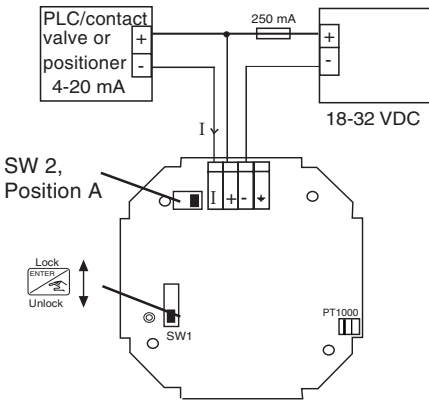

Fig. 3.15 Pin assignment, Position A

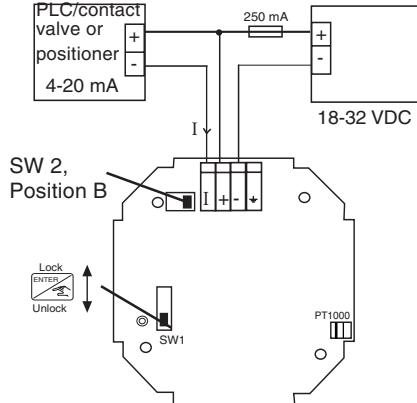

Fig. 3.16 Pin assignment, Position B

8175 WALL MOUNTED VERSION, RELAY CONNECTION

The electrical wiring of this model is possible via the use of 2 of the cable glands. Remove the cover via the screws on the front display and pull the cables through the PG 9 and wire according to pin assignment diagram below (Fig. 3.17).

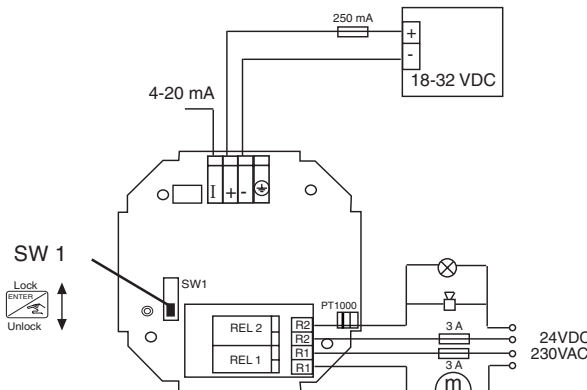

Fig. 3.17 Pin assignment for relays



- The device can be easily connected to a PLC independently of the respective version.
- The 'Enter' key can be locked by placing the SW 1 switch into the up position to avoid accidental or unauthorised access.



3.5 EASY LINK / NETWORKING CONNECTIONS

Easy CONTINUOUS PNEUMATIC LEVEL CONTROL

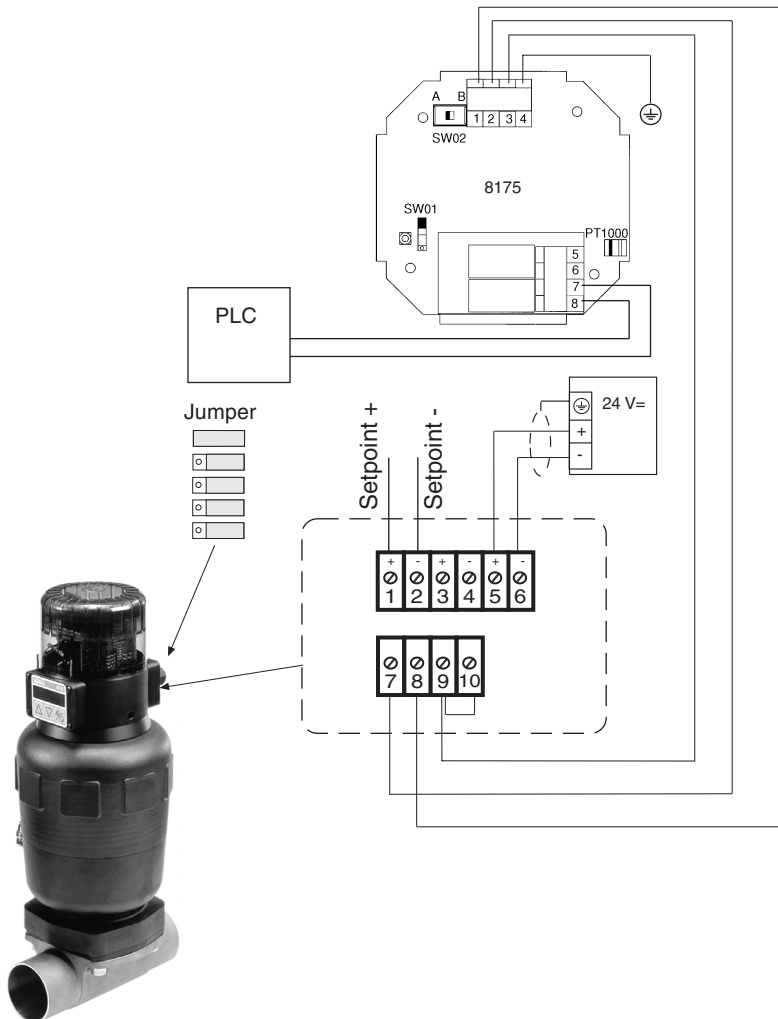

Example of *Easy* LINK between the 8175 level transmitter 18-32VDC and the 8630 Top Control mounted on a diaphragm valve type 2031.

Easy NETWORKING provided by the relay outputs



INSTALLATION

Easy CONTINUOUS PNEUMATIC LEVEL CONTROL

3.5 ENGLISH

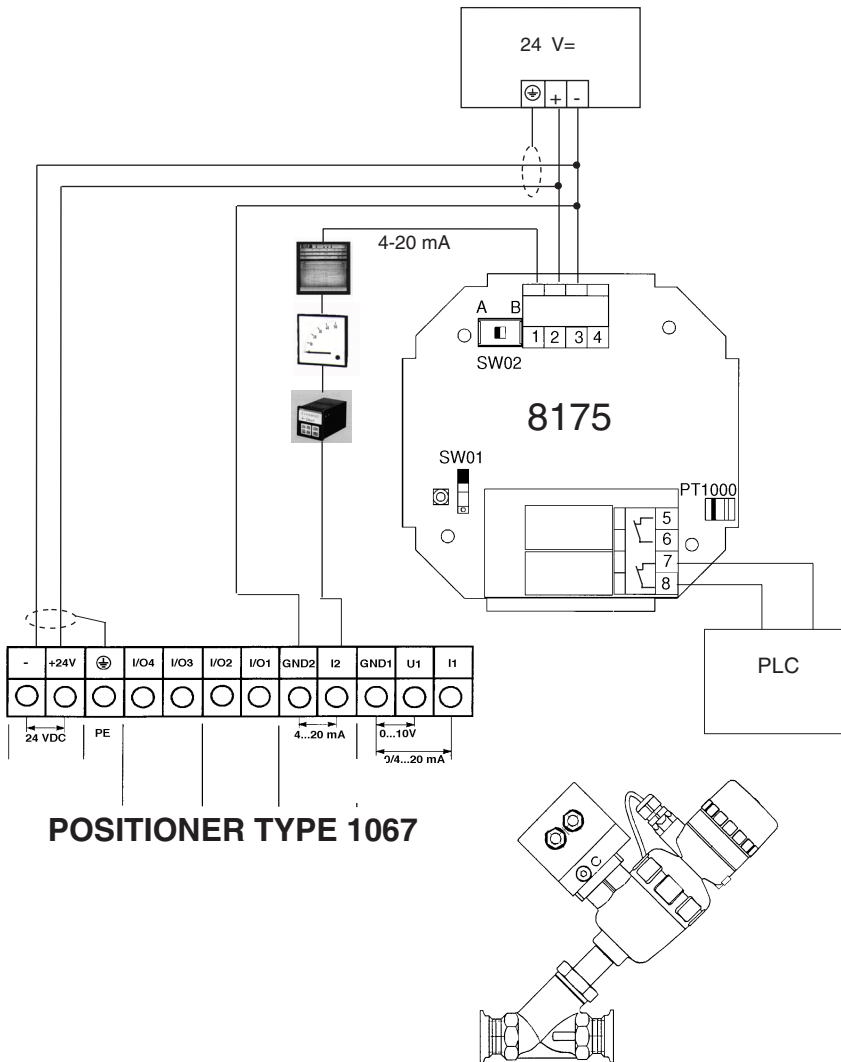

Example of *Easy* LINK between the 8175 level transmitter 18-32VDC and the 1067 positioner mounted on an angle seat valve type 2632.

Easy NETWORKING provided by the relay outputs.



Easy CONTINUOUS SOLENOID LEVEL CONTROL

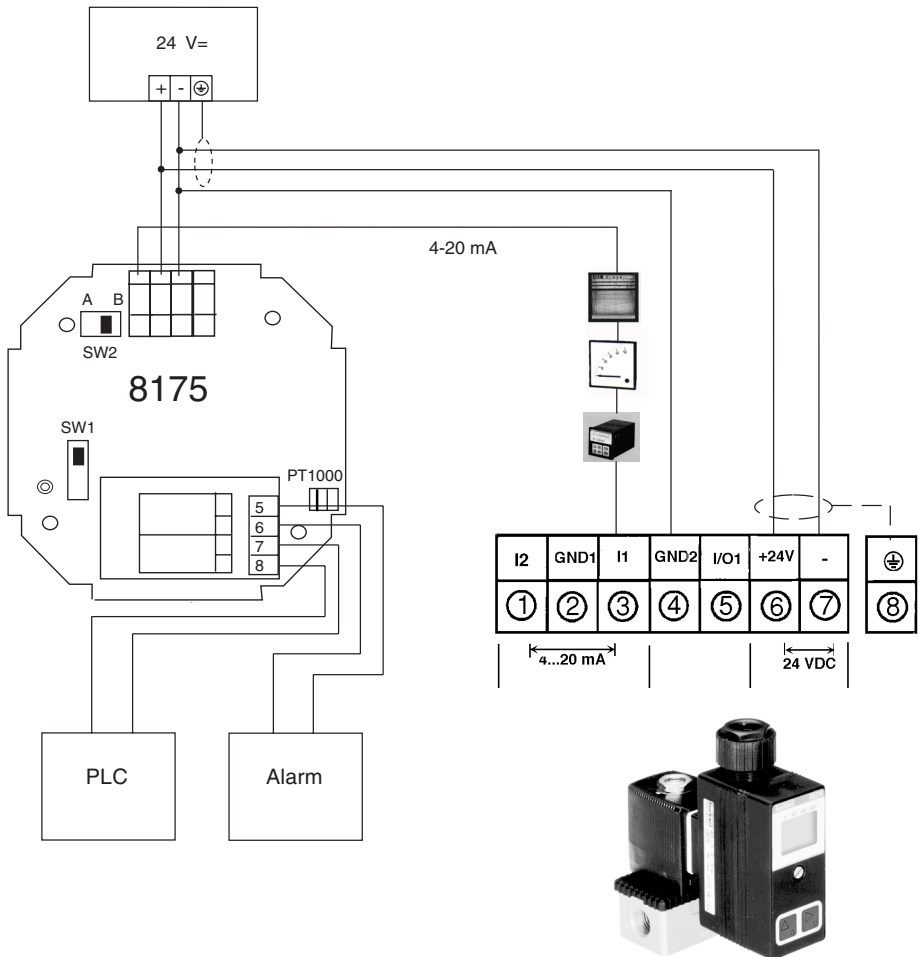

3.5 ENGLISH

Example of *Easy* LINK between the 8175 level transmitter 18-32VDC and the 8624 solenoid valve with PI controller.

Easy NETWORKING provided by the relay outputs.



INSTALLATION

Easy ON/OFF LEVEL CONTROL

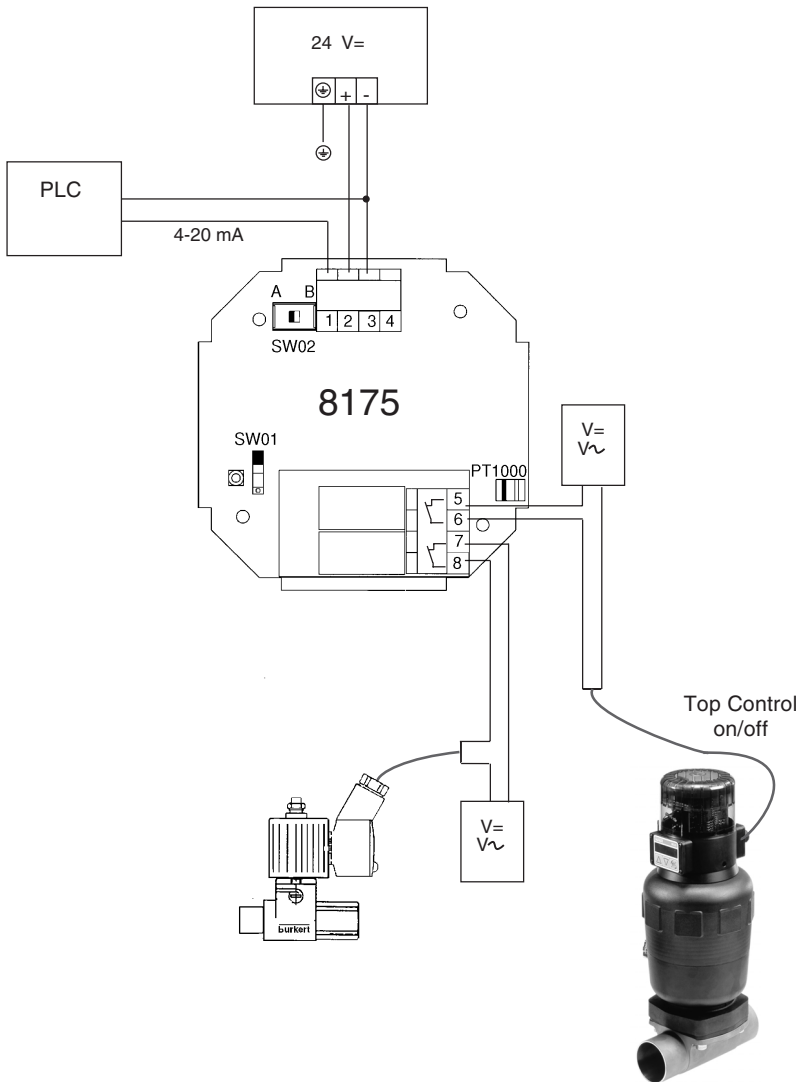

Example of *Easy* LINK between the 8175 level transmitter 18-32VDC and the 8631 Top Control on/off mounted on a diaphragm valve type 2031 and pilot valve type 6012.

Easy NETWORKING provided by the 4-20mA output



4.1 OPERATING AND CONTROL GUIDE

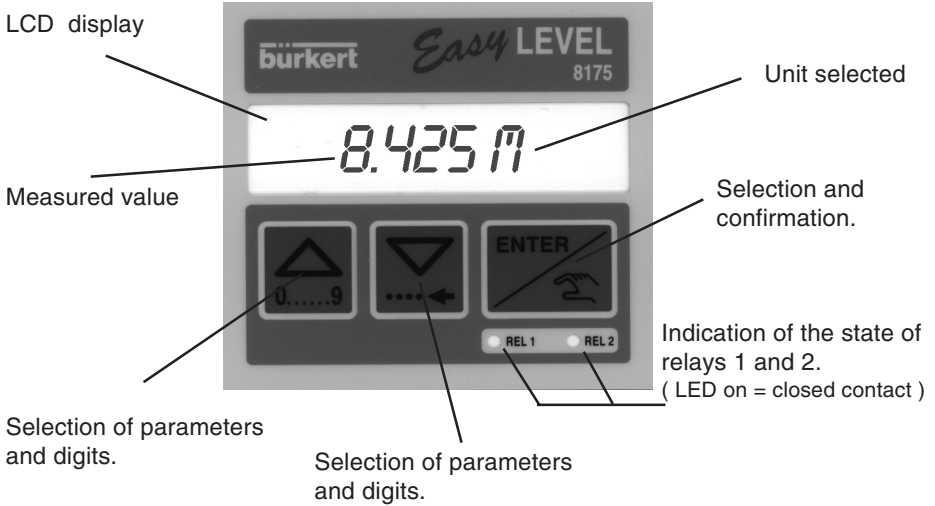

Keys	Mode Menu	Finding a value
	Previous Menu	Increase from the blinking digit
	Next Menu	Advance to the next digit
	Activate the menu display (If "END" is displayed, save the modified parameters and return to the main menu)	Validate the displayed value
 5 Seconds	Access to the CALIBRATION MENU*	
 5 Seconds	Access to the TEST MENU*	

* Only available within the main menu.



The Key can be locked to avoid accidental or unauthorised access.

For further information see section 3.3.



OPERATION

4.2 MENU GUIDE



The menu guide below will assist in quickly and easily finding a desired parameter and programming the 8175 ultrasonic level transmitter.

MAIN MENU

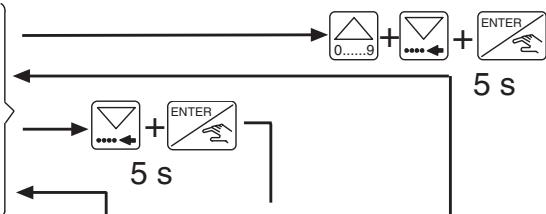

CALIBRATION MENU

- LANGUAGE
- UNIT
- FILTER
- GAS COMP
- ECHO
- TEACH-IN
- CURRENT
- RELAY
- END

TEST MENU

- OFFSET
- SPAN
- T° ADJUST
- SIGNAL
- SIMUL
- RESET
- END



4.2 ENGLISH



4.3 MAIN MENU

The following information is displayed within the Main Menu:

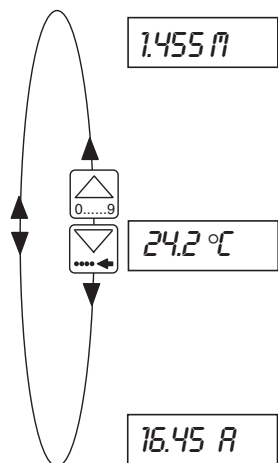

Measured Value: This is displayed as Level, distance or volume in the required engineering unit chosen within the calibration menu - see next section.

Gas Temperature: This is a display of the temperature of the gas in the engineering unit selected within the calibration menu.



If '--- °C' is displayed within this option the measured temperature is out of range.
(Range -40 to +95°C)

Output Signal: The standard output signal range is proportional to the selected measuring range.
(Range 4.00mA to 20.00mA with a 22mA error signal).



- The units will blink while the transmitter is performing an internal calculation.
- The whole display will blink when the signal has been lost or in cases of an electronic failure.



CALIBRATION MENU

4.4 CALIBRATION MENU









PRESS   SIMULTANEOUSLY FOR 5 SECONDS

The following parameters can be set within this menu:

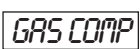
SECTIONS

4.4 ENGLISH



	Selection between English, German, French, Italian or Spanish.	4.4.1
	Selection of engineering units for level, distance or volume.	4.4.2
	Damping selection and delay time setting for signal failure alarm. There are ten different steps available. (<i>Range 0 to 9</i>).	4.4.3
	Gas characteristics (velocity of sound and temperature influence).	4.4.4
 	Selection of the target level and if there are any fixed echos to be filtered and eliminated by the transmitter.	4.4.5
	Manual or automatic determination of the specific application parameters.	4.4.6
	Setting of the 4-20mA output signal range.	4.4.7
	Parameter definition of relays 1 & 2 for level, distance or volume, T° and/or failure alarm.	4.4.8
	Back to the operation mode; store the new parameters set.	



The following sections explain how to change the parameter values within the calibration menu above.



4.4.1 LANGUAGE



The selection of an alternative language is confirmed by the Enter-key and becomes immediately active.

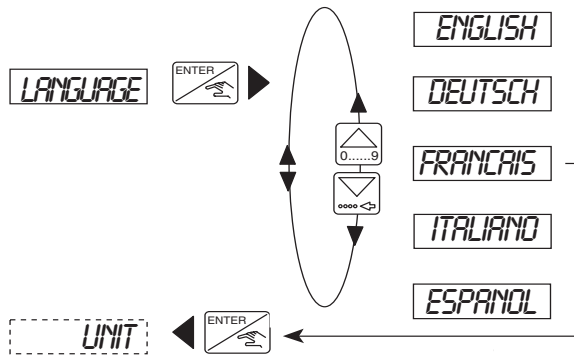

4.4.2 ENGINEERING UNITS

The selection of the units will depend on the application and the configuration of the transmitter via level, distance or volume for fluid measurement.



- If the transmitter is to be configured to measure Level or Distance, select the measuring units and decimal points as required.
- If volume is to be selected and configured it is important to note that the transmitter display within the 'VOLUME TEACH-IN' may not be the measuring units selected. The conversion of units by the transmitter only applies within the Volume Teach-In and the table below displays the measuring units selected and the displayed units which will be used within the Volume Teach-In.

SELECTED MEASURING UNITS		UNITS USED FOR TEACH-IN	
DISTANCE/LEVEL	VOLUME	DISTANCE	VOLUME
cm	l	m	l
m	l	m	l
cm	m ³	m	m ³
m	m ³	m	m ³
<i>cm</i>	<i>US/lmp gal</i>	<i>NOT VALID</i>	<i>NOT VALID</i>
<i>m</i>	<i>US/lmp gal</i>	<i>NOT VALID</i>	<i>NOT VALID</i>
<i>inch</i>	<i>l</i>	<i>NOT VALID</i>	<i>NOT VALID</i>
<i>foot</i>	<i>l</i>	<i>NOT VALID</i>	<i>NOT VALID</i>
inch	m ³	ft	m ³
foot	m ³	ft	m ³
inch	US/lmp gal	ft	US/lmp gal
foot	US/lmp gal	ft	US/lmp gal



CALIBRATION MENU

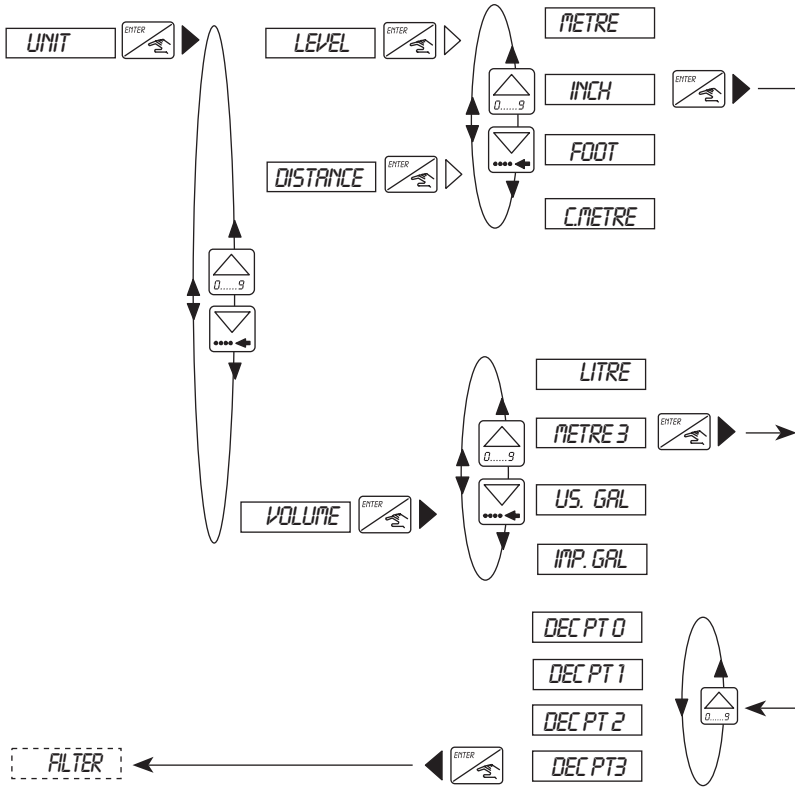

4.4.2 ENGLISH



The level, distance or volume can be displayed with 0, 1, 2 or 3 decimal places but 4 digits will always be displayed.



4.4.3 FILTER FUNCTION

The filter function provides a damping effect to prevent fluctuations within the output current and display. There are 10 levels of filtering available from 0 to 9 with 0 and 3 having no damping effect.



Echo Filtering:

The type of filter chosen will also affect the availability of the echo filtering function, as if filter 0,1 or 2 is chosen the option will not be available.

- If no echo filtering is chosen, it is advised to select filter 0 during the Teach-In calibration and after select the desired filter for the application.
- If echo filtering is necessary, set the transmitter to filter 3 during calibration in order to access this menu and after select the desired filter for the application.



Depending on the filter chosen there will be a maximum speed change for the recalculation of the level. This can be seen in the diagram below and the maximum speed change times are displayed in the following table. Choose the filter with a maximum speed change superior to that of your process.

The diagrams below display the relationship between the actual signal and the level of filtering.

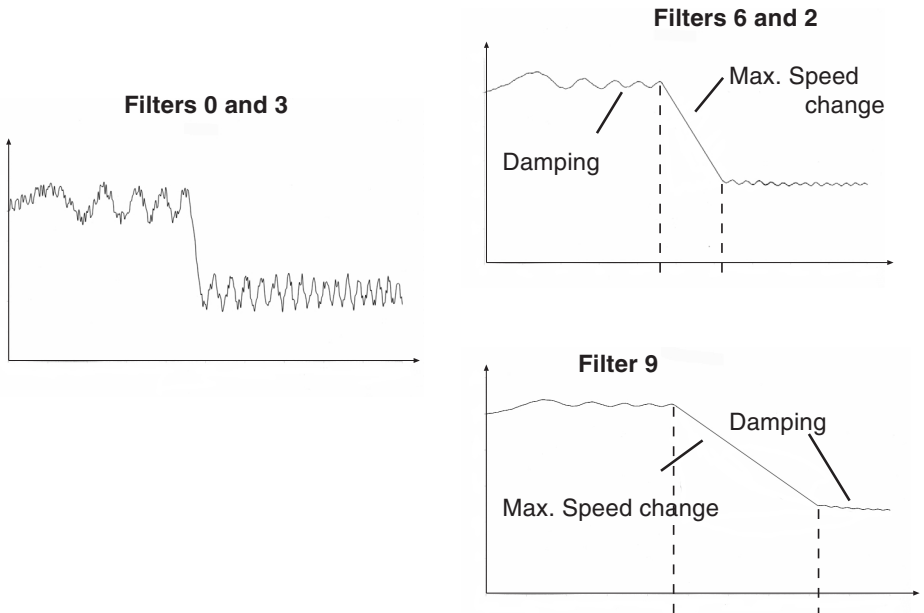



CALIBRATION MENU

Filter Level	Echo Menu available (see § 4.4.5)		Echo filtering		Maximum speed change
	Yes	No	Yes	No	
0		X		X	Immediate
1		X		X	10 m/min max
2		X		X	1 m/min max
3	X		X		Immediate
4	X		X		5 m/min max
5	X		X		2 m/min max
6	X		X		1 m/min max
7	X		X		0,5 m/min max
8	X		X		0,2 m/min max
9	X		X		0,1 m/min max

ENGLISH



- If relay 2 is to be configured as an alarm with a 22mA error signal **'DEFAULT'** the delay time must be set within this option.
- This delay time (DELA) will be activated at any time if the transmitter cannot find or measure the level. The delay time should be selected in respect to the process conditions eg: a short alarm time for a fast process control.

4.4.3

With the 8175 level transmitter it is additionally important to select the type of filter depending on the application. In some cases where a vessel is closed, echoes can be rebounded from the top of the vessel producing a 'doubling' effect. The **'CLOSED'** filter function ensures the filtering of this interference. If the filter is insufficient for the application the **'DOME'** filter can be used.



If the measurement is not 'doubled' or a precise detection and filtering of close objects is required select the **'OPEN TAN'** filter.

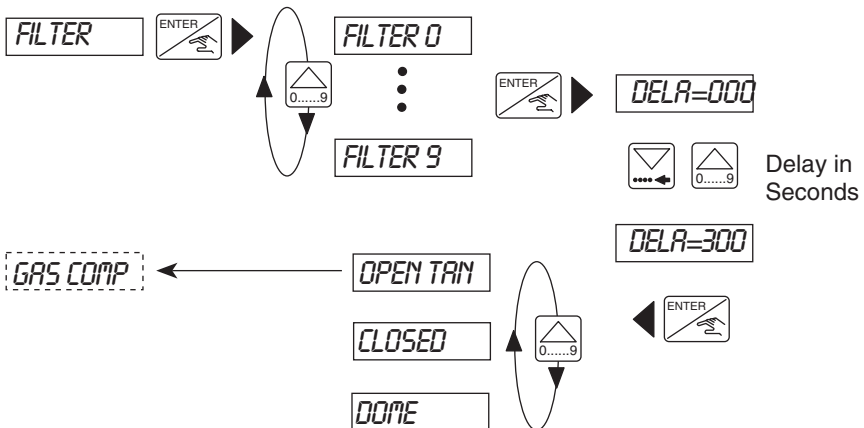



4.4.4 GAS CHARACTERISTICS

In order for the 8175 level transmitter to find a precise measure of the level, the characteristics of gas between the liquid and transmitter have to be defined.



- If this value is not known either a default value can be applied or the characteristics can be calculated by performing a 2 point Teach-In.
- Within this option the values must be entered in m/s or ft/s depending on the type of units selected (metric or imperial).

The default values for the gas characteristics are as follows:

Velocity of sound within the gas:



It is important that the velocity entered within this option is for the gas at a temperature of 0°C.

Default value: 331.4 m/s within air at 0°C (32°F)
1087.3 ft/s within air at 32°F (0°C)

Temperature variation of the velocity:

Default value: 0.59 m/s / °C
0.075 ft/s / °F

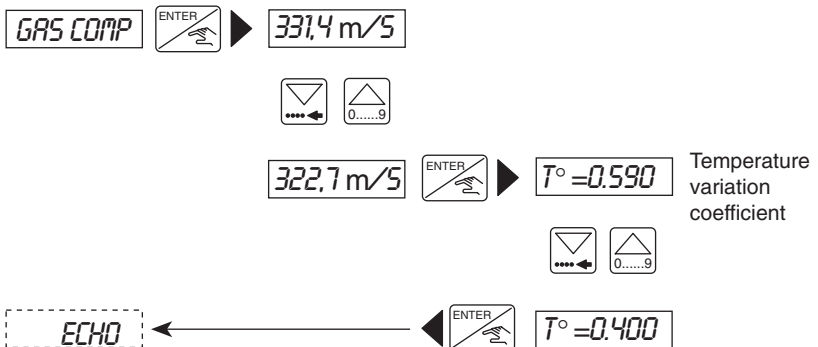

If no temperature dependency of the sound velocity is requested, calculate the sound velocity at ambient temperature with the following equation:

$$V = 331.4 \text{ m/s} + 0.59 \text{ m/s} \times T^{\circ}\text{C}$$

Enter this calculated value and enter 0.00 as the temperature variation coefficient.



CALIBRATION MENU

4.4.5 ECHO FILTERING

This function eliminates any fixed obstacles such as mounting elements, blades and inlet pipes which may interfere with the transmitter measurement giving an incorrect value and reading.



This function will only be available if a filter value between 3 and 9 has been selected within the filter function - section 4.4.3



This function should only be used if the echo returned and the displayed value is not the expected target.

Steps for successful echo filtering

- All obstacles to be identified must be between the transmitter and selected target.
- Enter the target distance **1** and press 'Enter' (fig.4.1) and the transmitter will process the information for approx. 10 seconds.
- The transmitter will search for the required target distance within +/- 0.5m.
- After processing the transmitter will display upto 10 echos identified in decreasing power order (the target level is generally the first value displayed) or the message 'ERROR' will be displayed.
- After select the echo for the target level and validate the procedure or exit.
- If the message 'ERROR' is displayed there has been no obstacles identified at the selected distance.

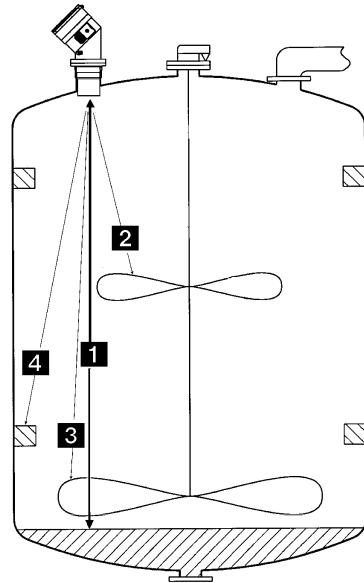
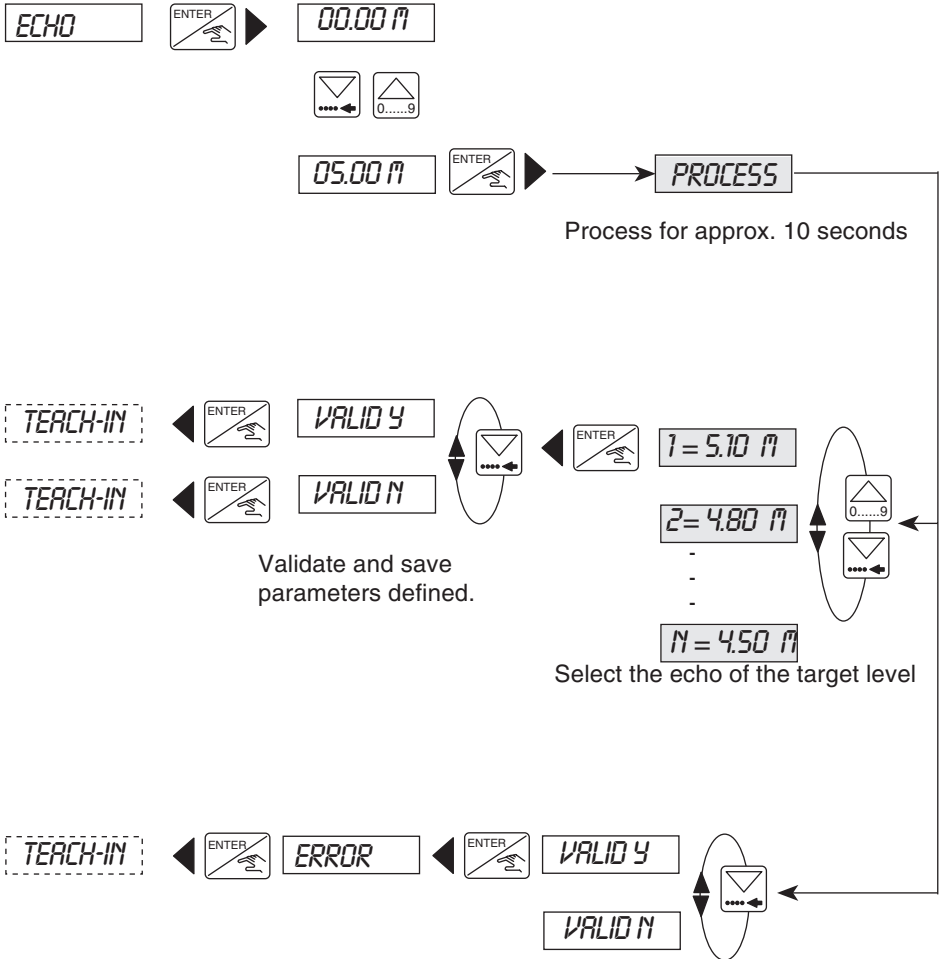

Fig. 4.1 Echo Filtering



- To assist with the completion of this function a schematical diagram is displayed in the next page.
- The echo identified and stored by this procedure can be erased by the reset function within the test menu (interference table) - section 4.5.6.



4.4.5 ENGLISH



CALIBRATION MENU

4.4.6 TEACH-IN PROCEDURES

The Teach-In function identifies and fixes the relationship between the transmitter display and the real distance, level or volume to ensure accurate measurement.



The transmitter automatically selects the appropriate Teach-In procedure (distance, level or volume) depending on the configuration and units selected within the engineering units function - section 4.4.2



- For the Teach-In procedures it is advisable to select either filter 0 or 3 (depending on echo filtering) during the Teach-In procedure for quick calculation of the measure and after select the desired filter.
- If volume has been selected for measurement and gas characteristics have to be defined, follow the procedures below:
 - Select distance or level with appropriate units within the engineering units.
 - Complete a 2 point Teach-In for identification of the gas characteristics and 'END' the menu to save the parameters.
 - Return to the engineering units and select volume and the appropriate units.
 - Complete a volume Teach-In to fix the transmitter display and the real distance, level or volume measurement.

ENGLISH
4.4.6

4.4.6.1 TEACH-IN FOR LEVEL AND DISTANCE

This function allows the relationship between the transmitter and fluid to be defined by distance or level.



- For distance measurement it is not necessary to complete a Teach-In procedure although for accurate measurement it is advised to complete at least a 1 point Teach-In.
- If the transmitter has been configured as level, it is necessary to complete at least a 1 point Teach-In.

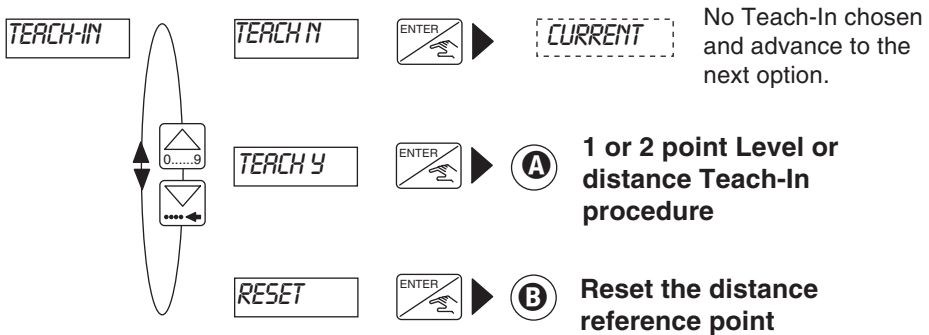

(Reset is not displayed if configured as level)



A - 1 OR 2 POINT LEVEL OR DISTANCE TEACH-IN PROCEDURE

This function identifies the relationship between the transmitter display and real measurements via entering 1 or 2 (point) distance measurements between the fluid and the base of the sensor.



- To obtain the best accuracy it is advised that a 2 point Teach-In is undertaken and the reference points are at the extremity of the application (level at minimum and maximum).
- The 2 point Teach-In will also define the sound velocity within the application if they have not been determined or defined.

STEPS FOR SUCESSFUL MEASUREMENT:

1 POINT LEVEL OR DISTANCE TEACH-IN:

- Adjust the level of fluid within the application so an accurate measurement can be taken between the base of the sensor and fluid level or to a known distance.
- Once the distance between the transmitter and fluid is known enter the Teach-In function and select *'TEACH Y'*.
- Enter the distance in the appropriate units and the transmitter will automatically calculate the difference between the distance entered and actual distance measured. (approx. 3 seconds).
- It is possible then to continue to complete a 2 point Teach-In for precise measurement or select *'END YES'* to validate the measurement or ignore the measurement and continue to the next function.

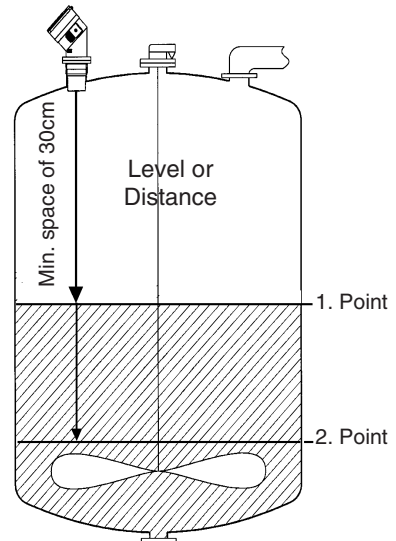

2 POINT LEVEL OR DISTANCE TEACH-IN:

- Complete the steps for the 1 point Teach-In although ensure that the reference points are at the extremity of the application (Min. and Max.).
- Select *'END NO'* after the first distance measurement has been entered and the transmitter has processed the information (difference).
- Fill or empty the tank/vessel to the new reference level and measure the distance.
- Enter the distance in the appropriate units and the transmitter will automatically calculate the difference between the distance entered and actual distance measured for a second time. (approx. 3 seconds).
- Select *'VALID Y'* to validate the option or ignore and advance to the next parameter.



CALIBRATION MENU

TEACH Y

1=0.000



Enter the first reference distance or level (1st Point).

1=0.065



PROCESS

CURRENT



VALID Y



END YES

CURRENT



VALID N

2=0.000



END NO



Enter the second reference distance or level (2nd Point).

2=0.130



PROCESS

CURRENT



VALID Y

CURRENT



VALID N

(B) - RESETTING OF THE DISTANCE REFERENCE POINT

This function is only available if the transmitter has been configured for distance measurement. Within this option it is possible to erase any user defined reference point and return to the 'default' reference point - the base of the sensor.



On receiving the transmitter the reference point will be configured as the base of the sensor.

RESET



VALID Y

0.....9

VALID N

CURRENT





4.4.6.2 TEACH-IN FOR VOLUME

This function allows the relationship between the transmitter display and real measurement to be defined by volume. This can be completed by entering:

- The dimensions of the tank or vessel (for regular shaped tanks and vessels only) - (C) or
- The input of up to 12 distances and associated volumes (for irregular tanks or vessels) - (D) or
- The input of up to 12 known volumes with distance measurement by the transmitter - (E)



Please pay attention to the units selected and the measured values entered within this option as the transmitter only uses meters and feet to calculate the volume.

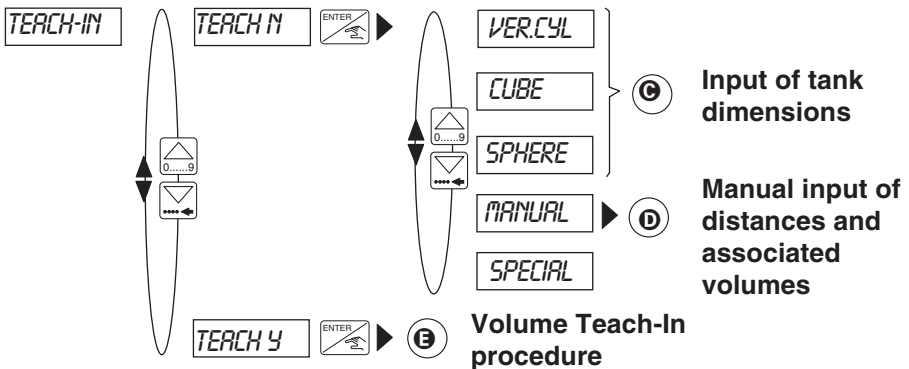

4.4.6 ENGLISH

(C) - INPUT OF TANK DIMENSIONS

This function identifies the relationship by entering the dimensions of the tank/vessel and the present volume.



- Within this function it is possible to select 1 of 5 options depending on the application and shape of the tank/vessel.
- Select one of the pre-determined shapes - 'VER.CYL', 'CUBE' or 'SPHERE' and enter the dimensions required.
- If 'MANUAL' is selected the transmitter automatically advances to the next option (D) to allow the user to manually input the distance measurements with associated volumes.
- The option 'SPECIAL' allows the user to select the previous volume Teach-In procedure completed.

This procedure allows the transmitter to compute the volume of the liquid contained in the tank/vessel according to the measured level of the fluid.



CALIBRATION MENU



- The diagram below displays the available options and the information required in the following format;
 - X = Radius
 - Y = Length
 - Z = Width.
- Enter the dimensions of the tank, then enter the actual present volume within the tank or vessel and the transmitter will automatically measure the distance and display the value.
- If an horizontal cylinder is to be used pre-calculate the values by using the table within section 6.2. After select and complete a manual input of distances and associated volumes procedure **D** by entering the values identified.

4.4.6 ENGLISH

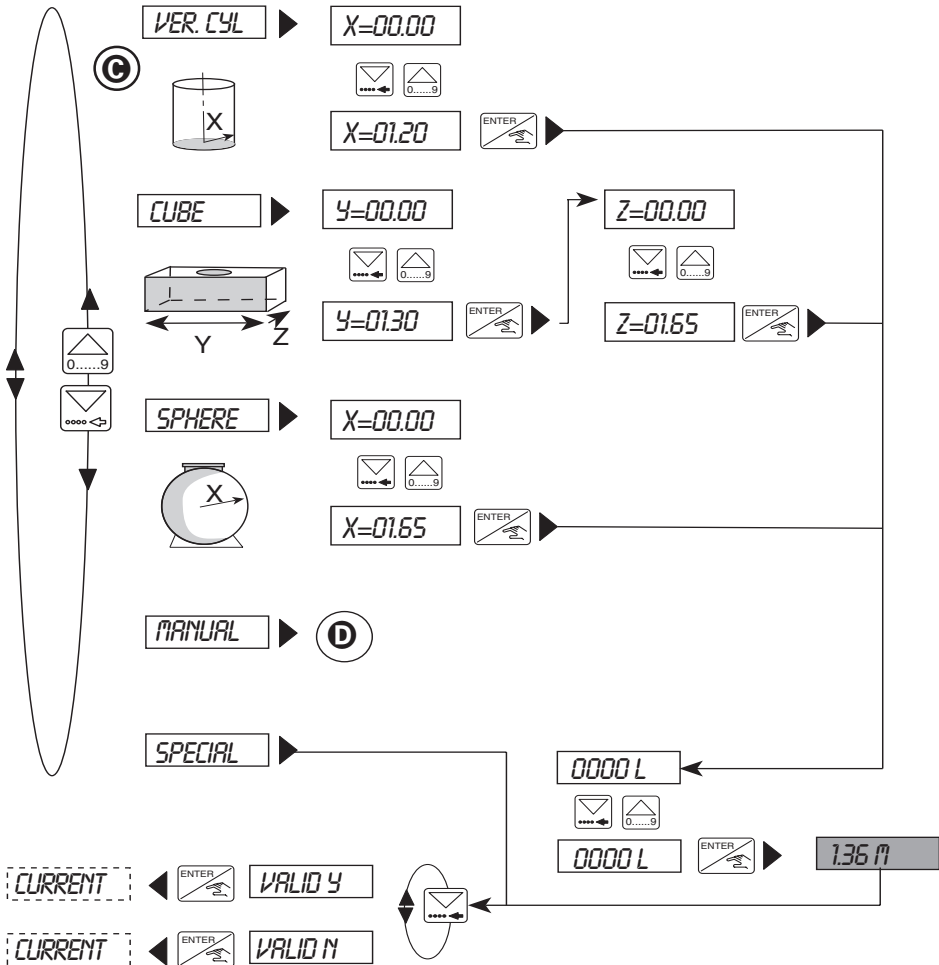



ⓓ - MANUAL INPUT OF DISTANCES AND ASSOCIATED VOLUMES

This function uses distances between the base of the sensor, fluid surface and associated volumes to fix the relationship between the transmitter display and real measurement.



- This function allows upto 12 individual distance and associated volume measurements to be entered.
- This option is generally used for irregular shaped tanks and vessels as it allows the input of individual distances and volumes.
- This function can be completed before the transmitter is installed onto the fitting.
- The accuracy of this function is highly dependent on the selected reference points according to the shape of the tank or vessel.

STEPS FOR SUCCESSFUL MEASUREMENT:

- Identify at least 2 reference points according to the shape of the tank or vessel for measuring the distances and entering the associated volumes.
- The values can be entered in either an increasing or decreasing order although the maximum volume which can be entered is 599.99m³ or 5999.9 litre/Gal.
- Select 'MANUAL' within the 'Input of Tank Dimensions' menu ⓓ and press enter.
- Enter the first distance measurement and press enter.
- Enter the associated volume which corresponds to the distance entered previously and press enter.
- Repeat the last 2 steps of entering the distance and associated volume.
- After entering the 2nd associated volume it is possible to quit the function by selecting 'END YES' and select to validate the option or ignore and advance to the next function. Alternatively it is possible to continue and enter a distance measurement and associated volume by selecting 'END NO' when the option appears. This can be repeated to enter a total of 12 measurements.

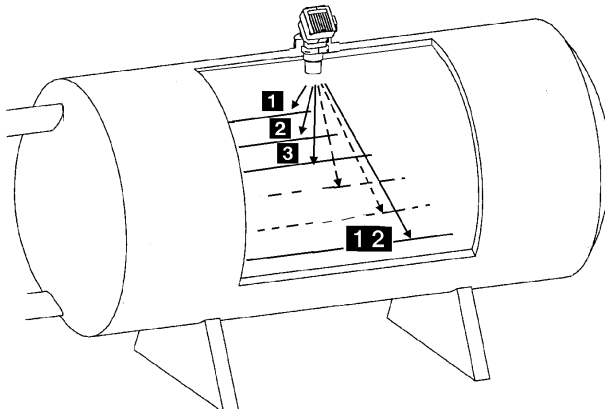



CALIBRATION MENU



If an incorrect value is entered, select 'END YES' and validate the measurements entered. Within the main menu (calibration) select 'END', then re-enter the menu and function and repeat the input of the measurements starting at the incorrect value.

MANUAL



00.00 M

D



Enter the first distance measurement

00.65 M



1-0000.0

Enter the first volume measurement



1-0013.0



00.00 M



Enter the second distance measurement

00.65 M



2-0000.0

Enter the second volume measurement



2-0035.2



CURRENT



VALID Y



END YES

CURRENT



VALID N



END YES



END NO

00.00 M

$N \leq 12$



Enter the nth distance measurement

02.05 M



N-0000.0

Enter the nth volume measurement



N-0041.1



- This option enables to display volume in a percentage for example or in alternative units. The units selected must then not be taken into account.
- In the same way, the 8175 can be used to display the flow rate within open channels.



ⓔ - VOLUME TEACH-IN PROCEDURE

This function identifies the distance between the base of the sensor and fluid surface and associated volumes are entered to fix the relationship between the transmitter display and real measurement.



- This function allows upto 12 individual associated volume measurements to be entered in relation to the distance measured by the transmitter.
- To perform this function the associated volumes must be known in relation to the measured distance.
- The accuracy of this function is highly dependent on the selected reference points according to the shape of the tank or vessel. (see diagram below)

STEPS FOR SUCCESSFUL MEASUREMENT:

- Identify at least 2 reference points according to the shape of the tank or vessel for entering the associated volume to the measured distance given by the transmitter.
- The tank or vessel can be filled or emptied for each reference point although the maximum volume which can be entered is 599.9m³ or 5999.9 litre/Gal.
- Select '*TEACH Y*' on entering the Teach-In function and press enter.
- The transmitter will automatically calculate the first distance measurement.
- If the distance measurement is correct, press 'enter' and insert the volume associated to the measured distance and press enter.
- The previous 2 steps will be repeated automatically as the transmitter requires at least 2 reference points.
- After entering the 2nd associated volume it is possible to quit the function by selecting '*END YES*' and select '*VALID Y*' to validate the option or ignore and advance to the next function. Alternatively it is possible to continue and enter associated volumes by selecting '*END NO*'. This can be repeated to enter a total of 12 measurements.

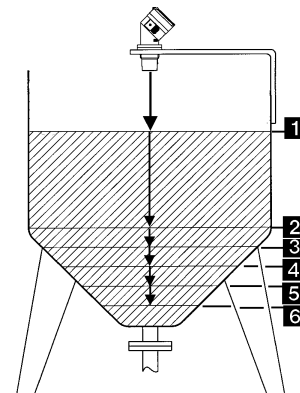



CALIBRATION MENU



If an incorrect value is entered the whole procedure will have to be repeated, starting at the first measuring point. The previous values entered will not be available for consultation, so it is recommended that the values are written down during this procedure.

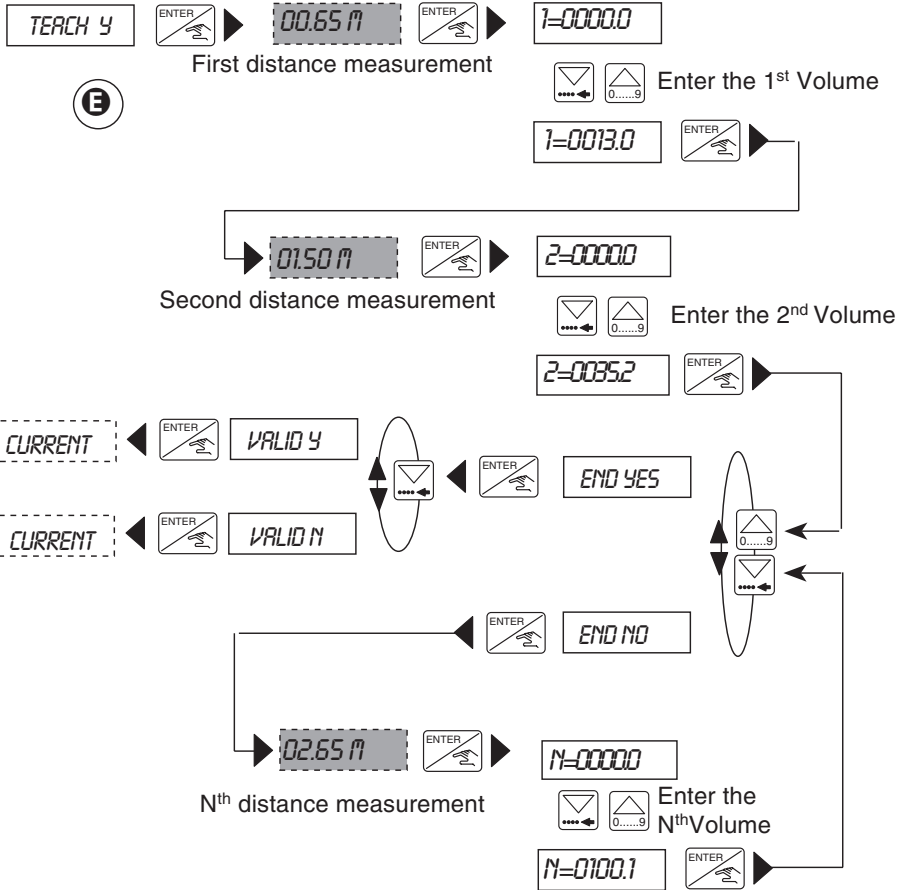

4.4.6 ENGLISH



4.4.7 OUTPUT CURRENT

Within this option the measuring range can be defined corresponding to the output current of 4-20 mA.



- The beginning of the measuring range might be larger than the end creating an inverted signal, e.g. 0.5 to 6m corresponds to 20-4 mA.
- The engineering units and decimal point selected will be valid within this option.
- The basic setting of the span and offset can be checked within the test menu.

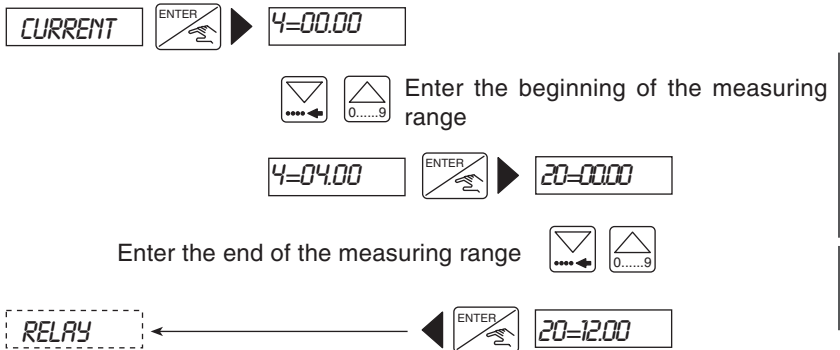

- In case of signal loss the device will emit an error signal of 22mA.
- The diagram below shows the type of relationship between the 4-20mA output and the associated measuring range.

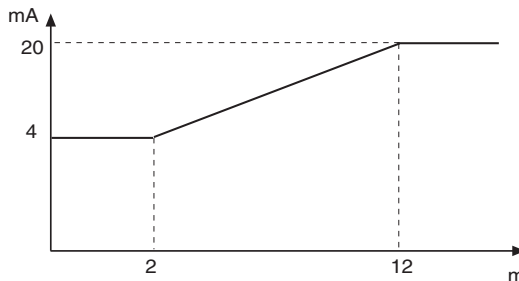



CALIBRATION MENU

4.4.8 RELAY (OPTION)

The parameter definition of the limit contacts is completed within this function. Two limit values are entered for each relay : 1 -, 1 + and 2 -, 2 +. The transmitter also has the option to invert the relays and to set a delay time between 0 and 180 seconds. This delay shall prevent the relays from being activated too quickly. If the measured value exceeds a limit value, the transmitter will wait for the designated delay time before activating the relay. If the value does not exceed the limit value after the delay time, the relay will not be activated.



The unit and decimal point for level, distance, volume or temperature are activated within this option as selected within the "LIMIT" menu (see section 4.4.2).



The following conditions must be observed: $1- \leq 1+$, $2- \leq 2+$.



- A** Relay 1 : Non inverted with thresholds of 2 and 4 m³ and no delay.
- B** Relay 2 : Inverted with thresholds of 6 and 8 m³ and delay of 2 Sec.

1- and 2- = the low settings for both relays
 1+ and 2+ = the high settings for both relays

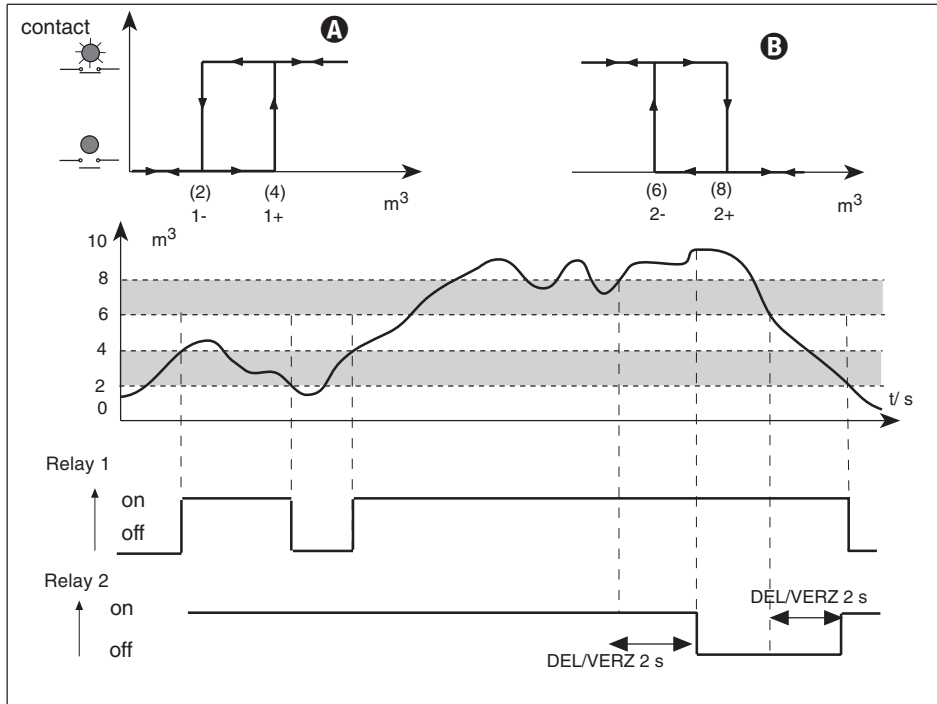



4.4.8.1 RELAY 1

Relay 1 is configured as distance, level or volume switch/alarm depending on the units selected within section 4.4.2.

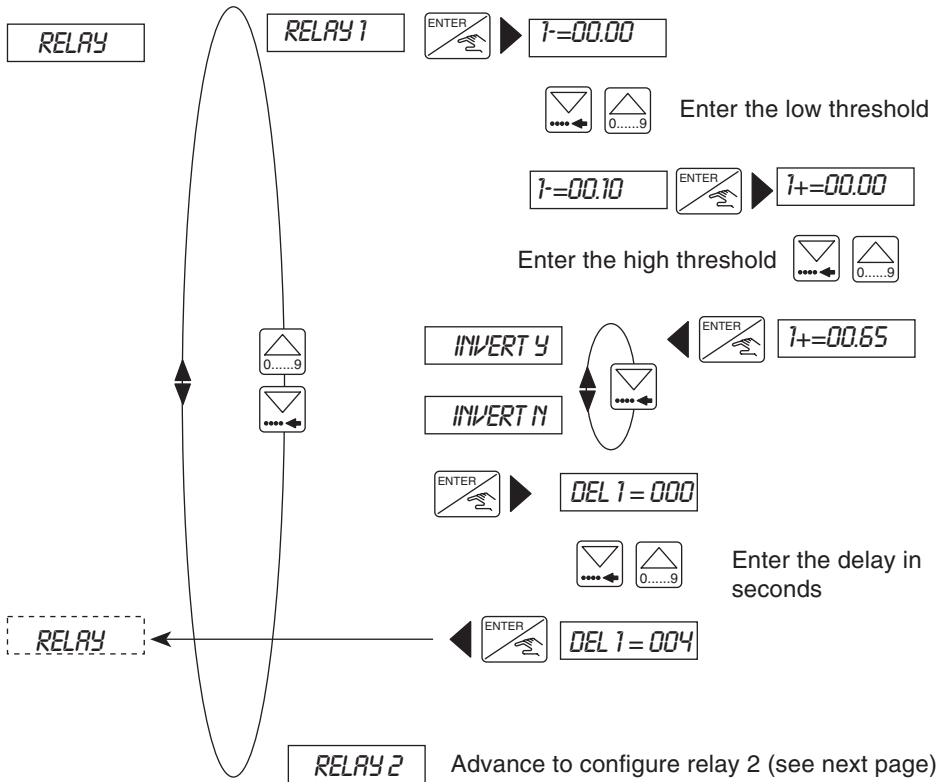

4.4.8 ENGLISH



CALIBRATION MENU

4.4.8.2 RELAY 2

Relay 2 maybe configured as a distance, level, volume switch/alarm or temperature general alarm signalling a signal loss or power supply failure.



- If relay 2 is configured as a signal loss alarm (default), ensure that the final state of the relay is in the safe state. For example: In case of a power failure alarm invert the relay and set a delay time greater than 10 seconds in order to avoid faulse alarms.
- The delay of the alarm if in 'default' is set within the filter function - section 4.4.3.

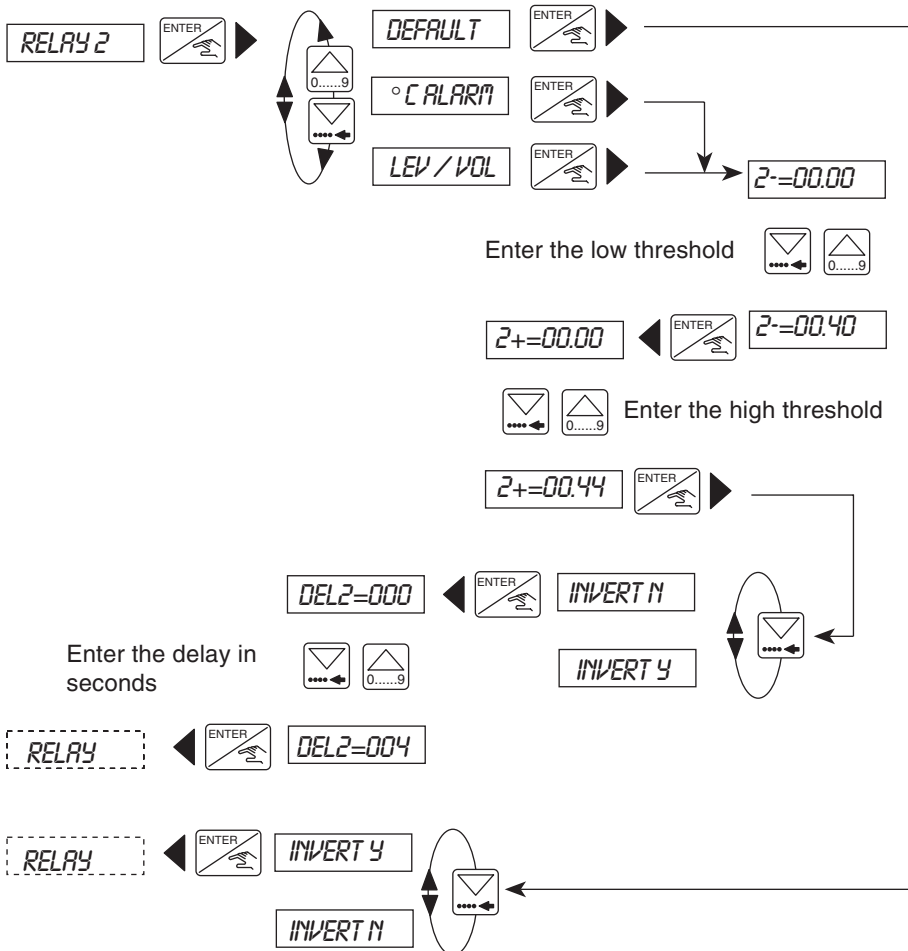



ENGLISH
4.4.8



4.5 TEST MENU

PRESS    **SIMULTANEOUSLY FOR 5 SECONDS**

The following parameters are selected and set within this menu;

		SECTIONS	
	OFFSET	Zero point compensation (4 mA).	4.5.1
	SPAN	Span compensation (20 mA).	4.5.2
	T° ADJUST	Temperature correction +/- 15°C .	4.5.3
	 SIGNAL	Display of the returned signal strength.	4.5.4
	 SIMUL	Input of the level, volume or temperature to be simulated. The current and relay outputs will react according to this value.	4.5.5
	RESET	Reset of the device to the factory settings and resetting of the interference table.	4.5.6
	END	Return to the main menu and store the new parameters. If one of the two values for OFFSET and SPAN is inappropriate, the device will automatically return to the "OFFSET" parameter and new values must be entered.	



The following sections explain how to change and investigate the parameter values within the test menu above.



TEST MENU

4.5.1 OFFSET COMPENSATION

Within this option the user has the possibility of correcting the basic setting of 4 mA generated by the transmitter. The transmitter generates a value of 4mA by pressing  when "OFFSET" is displayed within the main test menu.



Measure the generated current with an ammeter. If the displayed value is incorrect it can be corrected by entering the measured value on the ammeter.



Enter the measured value



ENGLISH

4.5.1

4.5.2 SPAN COMPENSATION

Span compensation provides the option of changing the basic setting of 20 mA. The procedure is identical to that of the offset compensation above. The transmitter generates 20mA if the  key is pressed when "SPAN" is displayed within the main test menu.



Measure the generated current with an ammeter. If the displayed value is incorrect it can be corrected by entering the measured value on the ammeter.



Enter the measured value





4.5.3 TEMPERATURE ADJUSTMENT

The 8175 level transmitter possesses a temperature probe within the sensor. The value from this sensor can be influenced by an offset entered within this option. To enter a desired offset press  when "T ° ADJUST" is displayed within the test menu and enter the value.



- The offset range is + or - 15°C.
- The temperature adjustment remains active until another temperature value is entered.



Enter the temperature offset in (°C or °F)

   

4.5.4 STRENGTH OF RETURN SIGNAL

This function allows the power of the ultrasonic echo received by the sensor to be viewed. When the optimum signal strength is 90 dB the transmitter has a measuring range of 7m for the remote version and 10m for compact version. The strength of this signal is maximum if the temperature of the gas and liquid are equal or the surface of the fluid is calm.



This measure is useful to determine the best orientation of the transmitter during installation. The best orientation is reached when the signal strength is at the highest value possible.

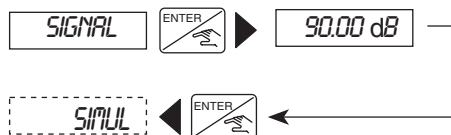



TEST MENU

4.5.5 SIMULATION OF THE LEVEL OR TEMPERATURE

A level or temperature can be simulated within this function which allows the control system to be tested whatever the conditions of the tank or vessel. The simulated value influences the current output including the relays.



The units and decimal points selected within the engineering units are valid within this function.

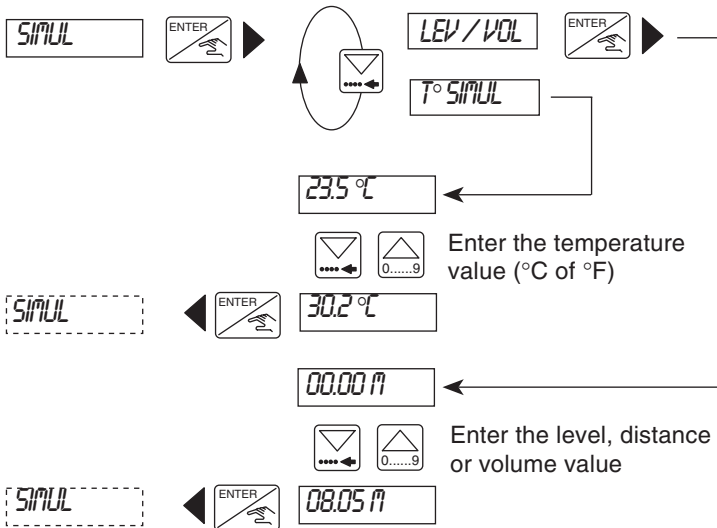

Press or to quit the simulation sub-menu and let the output be automatically determined by the transmitter according to the application.

ENGLISH
4.5.5



4.5.6 RESETTING OF THE TRANSMITTER

Within this function it is possible to erase the interference signals identified within the echo filtering function or return to the factory settings displayed on the next page.



If a filter value of 0 to 2 is selected within the option 'ECHO RES' will not be displayed.



If the resetting of the transmitter to the factory settings is selected it is important to note that the procedure is irreversible.

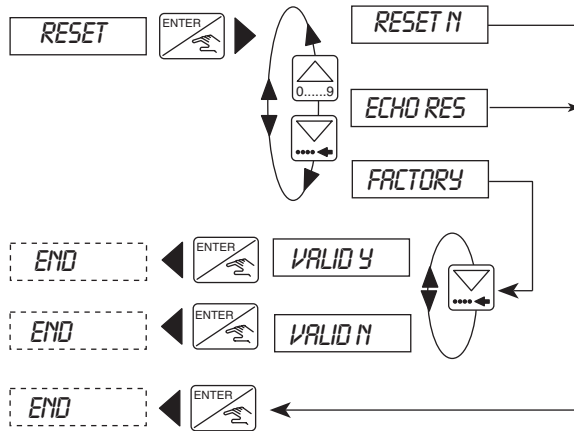

4.6 8175 SETTINGS

The 8175 ultrasonic level transmitter is calibrated within the factory before delivery to the settings shown in the table below.

4.6.1 FACTORY SETTINGS OF THE ULTRASONIC LEVEL TRANSMITTER TYPE 8175 AT DELIVERY

Language:	English	Relay:	1-:	00.00
Measure / Unit	Distance M		1+:	00.00
	Temperature °C		Del1:	0 s
Decimal points:	2		Invert:	NO
			2-:	00.00
Current:	4 mA: 00.00		2+:	00.00
	20 mA: 00.00		Del2:	0 s
Gas Comp.:	V=331,4 m/s		Invert:	NO
(air at 0°C)	T°=0,59 m/s/°C			
Filter:	0			
Dela:	10 s			

4.6.2 USER SETTINGS OF THE ULTRASONIC LEVEL TRANSMITTER TYPE 8175**IDENT. NO :****SERIAL NO :**

Language:	Relay:	1-:
Measure / Unit		1+:
		Del1:S
Decimal points:		Invert:
			2-:
Current:	4 mA:		2+:
	20 mA:		Del2:S
Gas Comp.:	V=		Invert:
(air at 0°C)	T°=			
Filter:			
Dela:			



5.1 STORING AND CLEANING OF THE SENSOR

Ultrasonic level sensors do not require any special maintenance, however, the bottom of the sensor must not be covered by sediments. If necessary the sensor can be easily cleaned using a soft bristled brush and detergent compatible with PVDF. Do not use harsh abrasive brushes or solutions which may damage the PVDF sensor enclosure.



Ensure that the tank / pipe does not contain any fluid or pressure before dismantling.

5.2 TROUBLE SHOOTING GUIDE



If any problems persist, please contact your local Bürkert subsidiary or return the product with a full explanation of the problem.

This section is designed to assist with problems which may occur during installation or operation. If in doubt, please do not hesitate to contact your local Bürkert subsidiary.

Faults	Status	Actions	
The transmitter does not work			
Transmitter connected ?	No	Connect the device	3.3
Fuses OK (if any) ?	No	Change the fuses	----
Switch ON (if any) ?	No	Set the switch ON	----
Power supply on terminal IN+ and IN- OK ?	No	Check the connection	3.3
Transmitter programming unavailable			
Switch SW01 down (ENTER key locked) ?	No	Set SW01 switch down	3.3
Is configuration impossible	Yes	Reset to factory settings	4.5.6
Display 'ERROR'			
Display at the start-up (EEPROM failure) ?	Yes	Restart the device	----
Error at each start-up?	Yes	Return the device	----
Display after validation of the menu (EEPROM failure)	Yes	Configure the device again	4.4
Failure at each validation of the menu?	Yes	Return the device	----
Display within the Teach-In mode ?	Yes	Perform the Teach-In again	4.4.6
Display ' ---- °C' or ' ---- °F'			
Temperature fluid between -40-80°C/-40-+176°F ?	No	Device out of range	----
Black connector for Pt1000 connected ? (Open the transmitter)	No	Connect the Pt1000 connector	----
Blinking display of the transmitter			
Blinking unit ? (m, cm, inch, foot, m3, l, US Gal, IMP Gal)	Yes	Perform an echo reset	4.5.6
Blinking of the whole display ?	Yes	Check the connection of connectors	3.3

ENGLISH

5.1



MAINTENANCE

Faults	Status	Actions	
Current output of 22 mA			
Fluid temperature between -40-80°C/-40--+176°F ?	No	Device out of range	----
Display blinking ?	Yes	See previous page	4.5.6
Display message 'ERROR' ?	Yes	Re-calibrate the unit	4.4
Current output value zero or different from the display			
SW2 correctly set (sinking or sourcing) ?	No	Modify SW2	3.3
Connection of the current output OK ?	No	Connect current output	3.3
Failure < 1 mA ?	Yes	Set the offset and span	4.5
Fixed current output value (4 or 20 mA)			
Parameters for current output OK ?	No	Program the current output	4.4.7
The devices connected to the relays do not work			
Parameter relays OK ? (threshold, inversion and delays)	No	Program the relay output again	4.4.8
Relays correctly connected ?	No	Connect relays	4.4.8
Connection of relays 1 and 2 inverted ?	Yes	Connect relays accordingly	4.4.8
Protection fuses for the relays OK (if any) ?	No	Change the fuses	----

ENGLISH

5.2

6.1 SPECIFICATIONS

Specifications in relation to the process

Measurement

Measurement type	Level, distance or volume measurement
Measurement range	0.30 to 10 meters compact version and 0.30 to 7 meters wall and panel versions
Measurement range in the following conditions:	Measure of the fluid without foam, $T_{\text{ambient}} = 20^{\circ}\text{C}$; $T_{\text{fluid}} = 20^{\circ}\text{C}$ Ambient pressure value : atmospheric pressure
Accuracy	+/- 0.25% of the full scale +/- 0.15% after calibration with Teach-In
Resolution	+/- 3mm
Full beam width	8 degrees conical
Pulse rate	8 pulses per second
Blocking distance	30 cm from the base of the sensor

Installation

Pressure rating	2 bar at 25°C maximum
Mounting threads	2" G or 2" NPT
Fluid temperature	-40 to +80°C / -40 to +176°F
Gasket material	FPM or EPDM (option)

Specifications in relation to the control outputs

Electrical connection

Power supply	18-32VDC 115/230 VAC 50-60Hz (+/- 10% VAC only)
Consumption	200mA maximum

Proportional output

Output type	Current output of 4-20mA (22mA error signal)
Accuracy	+ / - 2%
Wiring	Sinking or sourcing
Maximum load	1300 Ohms at 32V 1000 Ohms at 24V 550 Ohms at 18V
Output calibration	4-20mA or inverted to 20-4mA adjustable

Relay output

Output type	2 relays (3A), normally open
Load	DC : 250V, 3A AC : 250V, 3A
Life expectancy	100 000 cycles (minimum)
Thresholds	Hysteresis and delay programmable according to the level, distance, volume or temperature.



SPECIFICATIONS

Specifications in relation to the user

User's interface

Display	8 digits alphanumeric LCD 9mm high
Display :	
Current output	Generated current indication : xx.xx mA
Relay state	Red LED's on when contact is closed
Programming	Menus with 3 programming keys
Protection	Lockable switch for the 'Enter' key

Processing

Assistance for commissioning	Simulation of the level or volume to check correct running of the installation
Filtering of the measure	10 levels of filtering (filter 0...9)
Temperature adjustment	Programmable depending on the gas medium

Specifications in relation to the environment

Ambient conditions

Storing temperature	-20 to +60°C / -4 to +140°F -40 to +80°C / -40 to +176°F (for the remote sensor)
Humidity	Maximum of 80%
Operating temperature	-20 to +60°C / -4 to +140°F -40 to +80°C / -40 to +176°F (for the remote sensor)
Humidity	Maximum of 80%
Enclosure rating	IP65 (Compact, Wall & Panel front) IP20 (Interior of panel version)
Enclosure sensor rating	IP67

Construction

Dimensions maximum	See section 6.3
Weight	1kg maximum

Materials in contact with the environment

Electronic housing	PC (20% glass reinforced fiber) ABS (Wall version)
Transducer material	PVDF /POM
Front plate	Polyester

Conformity to standards

Emission	According to generic norm EN 50081.1
Immunity	According to generic norm EN 50082.2 It is important to note that in case of disturbance of the 40-80MHz provided by the cables, the output current may deviate and drop by 10%.
Safety	According to safety regulations for measuring instruments for regulation and laboratory NF EN 61010-1

6.1 ENGLISH

6.2 HORIZONTAL CYLINDRICAL TANK VALUE CONVERSIONS

For the calculation and input of the measured values for a horizontal cylindrical tank, both the level % and Volume % relationships have to be calculated and then entered within the manual input of distances and associated volumes procedure.



To calculate the values a table below has been provided to assist with the calculations.

Level in %	Level (chosen unit)	Volume in %	Volume (chosen unit)
0		0,00	
10		5,20	
20		14,24	
30		25,23	
40		37,35	
50		50,00	
60		61,64	
70		74,77	
80		85,76	
90		94,79	
100		100,00	

Steps for value calculation

- Identify the maximum level and volume for the application.
- Enter the maximum volume and level within the table (100%).
- Calculate the level values at the respective level percentages for the application (90% - 0%).
- Calculate the volume values for the respective volume percentages by multiplying the maximum volume of the application by the volume % within the table and dividing by 100.



After calculating the values perform a volume Teach-In - **D**.

6.3 DIMENSIONS

Cable plug version:

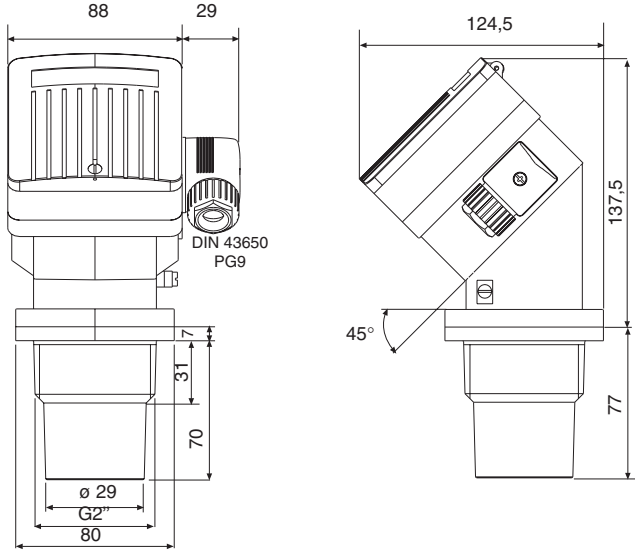

PG 13.5 & G 1/2" versions:

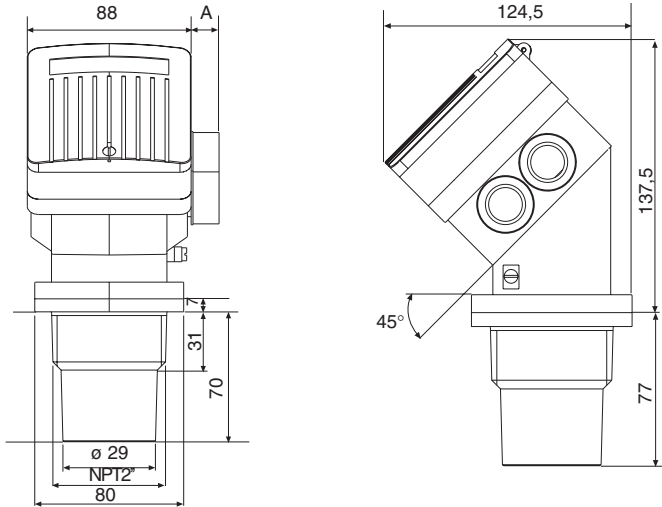

The dimension 'A' will vary depending on the type of connection selected - PG 13.5 = 28mm and G 1/2" = 15mm.

Panel mounted version:

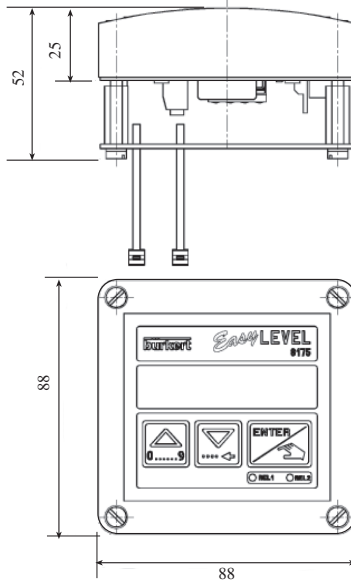

Wall mounted version:

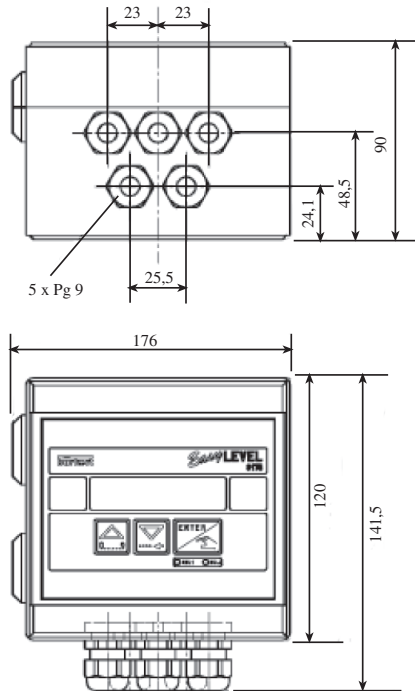

8170 Sensor:

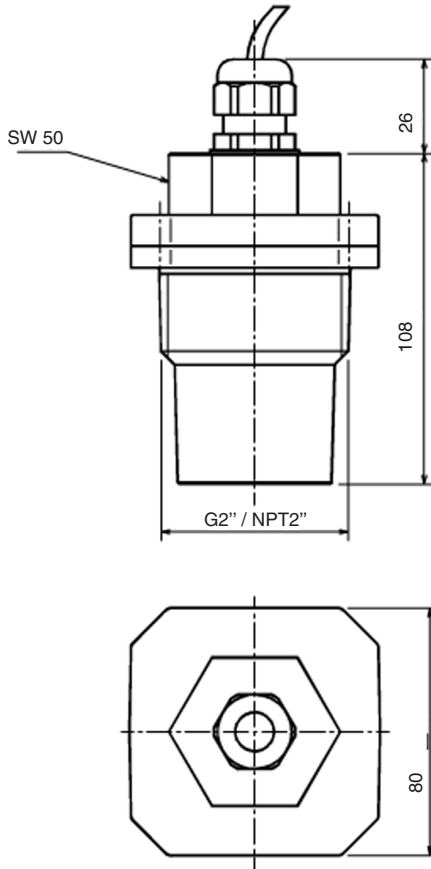

6.4 DESIGN AND MEASURING PRINCIPLE

6.4.1 Design

The ultrasonic level transmitter type 8175 compact combines an ultrasonic sensor and a transducer with display in a splash-proof plastic IP65 enclosure.

Alternatively the 8175 wall and panel versions integrate the ultrasonic sensor type 8170 to provide a remote version.

The output signals are provided via a connector or PG 13.5 / PG 9 (without relay) or via two PG 13.5 / PG 9 (transmitter with relays).

Option: 2 additional relays, which limit values are freely adjustable. The relay 2 may be used for signal loss control.

6.4.2 Ultrasonic Technology

Ultrasonic sound waves are generated 8 times per second. Sound waves can move with low attenuation in the air, but are reflected by any liquid or solid state surface. Between two consecutive emissions, advanced signal processing techniques, including air temperature adjustment and noise rejection ensures the return of the echo signals. Time of flight between emitted and received signal is measured with high accuracy and converted in distance (or volume) by the internal microprocessor.



The level transmitter or sensor types 8175 / 8170 are designed for liquid level measurement. It is the user responsibility to test the functionality of the device for any other material such as powders, granuals etc.

6.4.3 Signal Output

The Type 8175 ultrasonic transmitter is powered with 18-32VDC or 115/230VAC and features a 3-wire, 4-20 mA output. In addition the 3 A relay output can be configured as an alarm or for automatic fill or empty operations.

6.5 STANDARD DELIVERY

From a standard delivery you should have received the following:

COMPACT VERSION:

- 1 8175 level transmitter
- 1 Instruction Manual (3 languages)

SEPARATE VERSION:

- 1 8175 level transmitter (wall or panel version)
- 1 8170 sensor
- 1 Instruction Manual (3 languages)

(If the transmitter has 1 or 2 PG13.5 connections you should additionally receive 1 or 2 multiway seals depending on the version).



6.6 TYPE SPECIFICATION

Ultrasonic Level Transmitter Compact Type 8175

Worldwide types

4-20 mA output - 3 wires

Power supply	Relays	Mounting threads	Connector	Ident N°
18-32 VDC	No	G 2"	DIN 43650 PG 9	430822M
18-32 VDC	No	G 2"	PG 13.5	430823N
18-32 VDC	2	G 2"	2 x PG 13.5	430824P
115/230 VAC	No	G 2"	2 x PG 13.5	430825Q
115/230 VAC	2	G 2"	2 x PG 13.5	430826R

North America types

4-20 mA output- 3 wires

Power supply	Relays	Mounting threads	Connector	Ident N°
18-32 VDC	No	2" NPT	DIN 43650 G 2"	430827J
18-32 VDC	No	2" NPT	G 1/2 "	430828T
18-32 VDC	2	2" NPT	2 x G 1/2 "	430829U
115/230 VAC	No	2" NPT	2 x G 1/2 "	430830Z
115/230 VAC	2	2" NPT	2 x G 1/2 "	430831N

Ultrasonic Level Transmitter Pannel version Type 8175

Worldwide types and North America

4-20 mA output - 3 wires

Power supply	Relays	Connector	Ident N°
18-32 VDC	No	Terminal	436567P
18-32 VDC	2	Terminal	436568Y

Ultrasonic Level Transmitter Wall mounted version Type 8175

Worldwide types and North America

4-20 mA output - 3 wires

Power supply	Relays	Connector	Ident N°
18-32 VDC	No	5 x PG 9	436569Z
18-32 VDC	2	5 x PG 9	436570W
115/230 VAC	No	5 x PG 9	437339T
115/230 VAC	2	5 x PG 9	437340G

Ultrasonic Level Sensor Type 8170

Worldwide types and North America

Mounting Threads	Cable Length	Ident N°
G2"	10m	436563K
G2"	20m	436564L
NPT 2"	10m	436565M
NPT 2"	20m	436566N



6.7 LABEL TYPE 8175

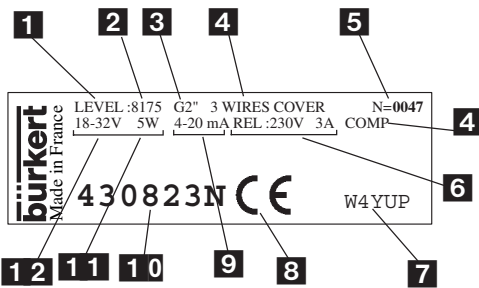

- | | |
|----|--|
| 1 | Level |
| 2 | Type |
| 3 | Process connection |
| 4 | Type specification |
| 5 | Serial number |
| 6 | Relay characteristics
(Factory internal N°) |
| 7 | CE mark |
| 8 | Output current |
| 9 | Ident. No. |
| 10 | Power/current consumption |
| 11 | Power supply |
| 12 | |

6.8 SPARE PARTS LIST

Level Transmitter Type 8175

Position	Specification	Ident N°
1	Cover with screws, sheetings and printed circuit board for transmitter without relay	430834R
	Cover with screws, sheetings and printed circuit board for transmitter with relays	430835J
2	Transmitter housing for DIN 43650 cable plug	427050X
	Transmitter housing for cable gland PG 13.5	430832P
	Transmitter housing for two cable glands PG 13.5	430833G
3	FPM seal kit	430749K
	EPDM seal kit	430750Q
4	Transmitter transducer for fitting G2"	427053N
	Transmitter transducer for fitting NPT 2"	427054P
5	Cable plug DIN 43650	424205Z
6	Cable plug DIN 43650 North American version	424206S
7	Cable gland PG 13.5 Worldwide version	418339Q
8	Cable gland PG 13.5 North American version (G 1/2 ")	418340M
	Power supply card 115/230 VAC	427435A
	Operating instruction manual Transmitter Type 8175	427998P

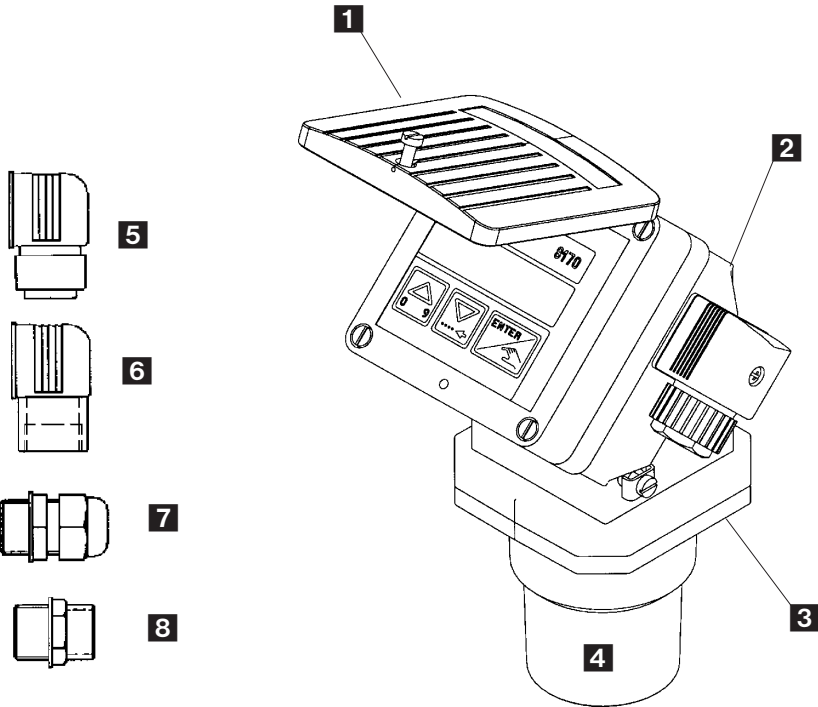

Fig. 6.1 Spare parts diagram of the 8175 ultrasonic level transmitter

SERVICE

Australia

Bürkert Fluid Control Systems
Unit 1 No.2, Welder Road
Seven Hills NSW 2147
Tel +61 (0) 2 967 461 66
Fax +61 (0) 2 967 461 67

Austria

Bürkert Contromatic GmbH
Central and Eastern Europe
Diefenbachgasse 1-3
A-1150 Wien
Tel +43 (0) 1 894 13 33
Fax +43 (0) 1 894 13 00

Belgium

Bürkert Contromatic N.V./S.A.
Middelmolenlaan 100
B-2100 Deurne
Tel +32 (0) 3 325 89 00,
Fax +32 (0) 3 325 61 61

Canada

Bürkert Contromatic Inc.
760 Pacific Road, Unit 3
Oakville, Ontario, L6L 6M5
Tel +1 905 847 55 66,
Fax +1 905 847 90 06

China

Bürkert Contromatic
(Suzhou) Co. Ltd.
2/F, 71 Zhu Yuan Road
215011 Suzhou
Tel +86 512 808 19 16
Fax +86 512 824 51 06

Bürkert Contromatic

China/HK Ltd.
Rm. 1313
No. 103, Cao Bao Road
200233 Shanghai P.R.C.
Tel +86 21 6427 1946
Fax +86 21 6427 1945

Bürkert Contromatic
China/HK Ltd.
Beijing Office
Rm. 808, Jing Tai Building
No. 24, Jianguomen
Waidajie
100022 Beijing P.R.C.
Tel +86 10 65 15 65 08
Fax +86 10 65 15 65 07

Bürkert Contromatic China/HK Ltd.

Cheng Du Representative Office
Rm. 502, Fuji Building
No. 26 Shududadao
Dongfeng Street
Chengdu P.R.C.
Tel +86 28 443 1895
Fax +86 28 445 1341

Bürkert Contromatic
China/HK Ltd.
Guangzhou Representative Office
Rm. 1305, Tower 2
Dong-Jun Plaza
Dongfeng, Road East
Guangzhou P.R.C.
Tel +86 28 443 1895
Fax +86 28 445 1341

Denmark

Bürkert-Contromatic A/S
Hørkær 24
DK-2730 Herlev
Tel +45 44 50 75 00
Fax +45 44 50 75 75

Finland

Bürkert Oy
Atomitie 5
SF-00370 Helsinki
Tel +358 (0) 9 549 706 00
Fax +358 (0) 9 503 12 75

France

Bürkert Contromatic
B.P. 21
Triembach au Val
F-67220 Villé
Tel +33 (0) 388 58 91 11
Fax +33 (0) 388 57 09 61

Germany / Deutschland

Bürkert Steuer- und Regeltechnik
Christian-Bürkert-Straße 13-17
D-74653 Ingelfingen
Tel +49 7940 10-0
Fax +49 7940 10 361

Niederlassung NRW
Holzener Straße 70
D-58708 Menden
Tel +49 2373 96 81-0
Fax +49 2373 96 81-52

Niederlassung Frankfurt
Am Flugplatz 27
D-63329 Egelsbach
Tel +49 6103 94 14-0
Fax +49 6103 94 14-66

Niederlassung München
Paul-Gerhardt-Allee 24
D-81245 München
Tel +49 89 82 92 28-0
Fax +49 89 82 92 28-50

Niederlassung Berlin
Bruno-Taut-Straße 4
D-12524 Berlin
Tel +49 30 67 97 17-0
Fax +49 30 67 97 17-66

Niederlassung Dresden
Christian Bürkert Straße 2
D-01900 Großbröschen
Tel +49 35952 3 63 00
Fax +49 35952 3 65 51

Niederlassung Hannover
Rendsburger Straße 12
D-30569 Hannover
Tel +49 511 9 02 76-0
Fax +49 511 9 02 76-66

Niederlassung Stuttgart
Karl-Benz-Straße 19
D-70794 Filderstadt (Bernh.)
Tel +49 711 4 51 10-0
Fax +49 711 4 51 10-66

Great Britain

Bürkert Contromatic Ltd.
Brimscombe Port Business Park
Brimscombe, Stroud, Glos.
GL5 2QF
Tel. +44 (0) 1453 73 13 53
Fax +44 (0) 1453 73 13 43

Hong Kong

Bürkert Contromatic
(China/HK) Ltd.
Unit 708, Prosperity Centre
77-81 Container Port Road
Kwai Chung N.T.
Hong Kong
Tel +852 248 012 02
Fax +852 241 819 45

Italy

Bürkert Contromatic Italiana S.p.A.
Centro Direzionale 'Colombiolo'
Via Roma 74
I-20060 Cassina De' Pecchi (MI)
Tel +39 02 959 071
Fax +39 02 959 07 251

Japan

Bürkert Contromatic Ltd.
3-39-8 Shoan
Suginami-ku
Tokyo 167-0054
Tel +81 (0) 3 3247 3411
Fax +81 (0) 3 3247 3472

Korea

Bürkert Contromatic Korea Co. Ltd.
4-10 Yangjae-Dong
Seocho-Ku
Seoul 137-130
Tel. +82 (0) 2 346 255 92
Fax +82 (0) 2 346 255 94

SERVICE

Malaysia

Bürkert Malaysia Sdn. Bhd.
N° 22 Lorong Helang 2
11700, Sungai Dua
Penang
Tel. +60 (0) 4 657 64 49
Fax +60 (0) 4 657 21 06

Netherlands

Bürkert Contromatic BV
Computerweg 9
NL-3606 AV Maarssen
Tel. +31 (0) 346 58 10 10
Fax +31 (0) 346 56 37 17

New Zealand

Burkert Contromatic Ltd.
Unit 5, 23 Hannigan drive
Mt Wellington
Auckland
Tel +64 (0) 9 570 25 39
Fax +64 (0) 9 570 25 73

Norway

Bürkert Contromatic A/S
Hvamstubben 17
Box 243
N-2026 Skjetten
Tel +47 63 84 44 10
Fax +47 63 84 44 55

Poland

Bürkert Contromatic Sp.z.o.o.
1 Szpitalna Street
PL-00-684
Warszawa
Tel +48 (0) 22 827 29 00
Fax +48 (0) 22 627 47 20

Singapore

Burkert Contromatic Singapore Pte.Ltd.
No.11 Playfair Road
Singapore 367986
Tel +65 383 26 12
Fax +65 383 26 11

Spain

Bürkert Contromatic Española S.A.
San Gabriel 40-44
E-08950 Esplugues de Llobregat
Tel +34 93 371 08 58
Fax +34 93 371 77 44

South Africa

Burkert Contromatic Pty.Ltd.
P.O.Box 26260, East Rand 1462
Republic of South Africa
Tel +27 (0) 11 397 2900
Fax +27 (0) 11 397 4428

Sweden

Bürkert Contromatic AB
Skeppsbron 13 B
S-21120 Malmö
Tel +46 (0) 40 664 51 00
Fax +46 (0) 40 664 51 01

Bürkert Contromatic AB

Havsörnstorget 21
Box 1002
S-12349 Farsta
Tel +46 (0) 40 664 51 00
Fax +46 (0) 8 724 60 22

Switzerland

Bürkert-Contromatic AG Schweiz
Bösch 65
CH-6331 Hünenberg / ZG
Tel +41 (0) 41 785 66 66
Fax +41 (0) 41 785 66 33

Taiwan

Bürkert Contromatic Taiwan Ltd.
3F No. 475 Kuang-Fu South Road
R.O.C - Taipei City
Tel +886 (0) 2 275 831 99
Fax +886 (0) 2 275 824 99

Turkey

Bürkert Contromatik
Akiskan Kontrol Sistemleri Ticaret
A.S
1203/8 Sok. No. 2-E
Yenisehir
Izmir
Tel +90 (0) 232 459 53 95
Fax +90 (0) 232 459 76 94

Tzechia

Bürkert Contromatic Spol.s.r.o
Prosenice c. 180
CZ - 751 21 Prosenice
Tel +42 0641 226 180
Fax +42 0641 226 181

USA/West/Main office

Burkert Contromatic Corp.
2602 McGaw Avenue
Irvine, CA 92614, USA
Tel. +1 949 223 31 00
Fax +1 949 223 31 98

USA/South

Burkert Contromatic Corp.
6724 Alexander Road
Charlotte, North Carolina, 28270
Tel. +1 704 367 11 73
Fax +1 704 367 11 74

USA/North-East

Burkert Contromatic Corp.
7173 Thermal Road
Charlotte, North Carolina, 28211
Tel. +1 704 366 21 41
Fax +1 704 366 24 28

USA/West

Burkert Contromatic Corp.
4449 East Bradford
Orange, CA 92867
Tel. +1 714 637 26 39
Fax +1 714 637 21 62

USA/Mid-West

Burkert Contromatic Corp.
6245 Kincora Court
Cincinnati, OH 45233
Tel. +1 513 941 34 78
Fax +1 513 941 29 05

