

<b>1.</b>	<b>INTRODUCTION</b> .....	<b>E-2</b>
1.1.	Check on delivery contents .....	E-2
1.2.	General Recommendations .....	E-2
1.3.	Safety Instructions .....	E-2
1.4.	Electromagnetic Compatibility .....	E-2
<b>2.</b>	<b>DESCRIPTION</b> .....	<b>E-3</b>
2.1	Type Designation .....	E-3
2.2	Construction and measurement philosophy .....	E-4
2.3	Dimensions .....	E-5
2.4	Technical Specifications .....	E-7
<b>3.</b>	<b>INSTALLATION</b> .....	<b>E-8</b>
3.1	Fitting instructions .....	E-8
3.2.	Installation .....	E-9
3.3.	General Instructions for Electrical Connection .....	E-11
3.4.	Electrical Connections for the compact version .....	E-11
3.5.	Electrical Connections for the compact version with 230/115 VAC supply voltage .....	E-12
3.6.	Electrical Connections for the panel version .....	E-13
3.7.	Electrical Connections for the wall-mounted version .....	E-15
<b>4.</b>	<b>CONFIGURATION</b> .....	<b>E-17</b>
4.1	Description of Dosage Options .....	E-17
4.1.1.	«LOC.MANU» Option .....	E-17
4.1.2.	«LOC.MEM» Option .....	E-17
4.1.3.	«MEM+MANU» Option .....	E-17
4.1.4.	«EXT.MEM» Option .....	E-18
4.1.5.	«EXT.[T]» Option .....	E-19
4.2.	Programming Keys on the Batch Controller .....	E-20
4.3	Main menu .....	E-21
4.3.1.	Dosage in manual mode .....	E-21
4.3.2.	Dosage in automatic mode .....	E-22
4.3.3.	Dosage proportional to a pulse duration .....	E-23
4.3.4.	Display of flow rate and the initial preset quantity during the dosage .....	E-23
4.3.5.	Pause / reset function .....	E-24
4.4.	Menu Calibration .....	E-25
4.4.1.	Language .....	E-25
4.4.2.	Measurement units .....	E-26
4.4.3.	K-Factor .....	E-26
4.4.4.	Dosage Options .....	E-27
4.4.5.	Overflow correction .....	E-29
4.4.6.	Alarms .....	E-29
4.4.7.	Relays .....	E-30
4.4.8.	Totalizer .....	E-32
4.5.	Test Menu .....	E-32
4.5.1.	EXT.ACT. .....	E-32
4.5.2.	Check on operation of relays .....	E-33
4.5.3.	Transducer frequency readout .....	E-33
<b>5.</b>	<b>MAINTENANCE</b> .....	<b>E-34</b>
5.1	Fault prompts .....	E-34
5.2.	Transducer maintenance .....	E-35
5.3.	Default configuration of 8025 Batch Controller on delivery .....	E-35
5.4	List of spare parts .....	E-36
	<b>APPENDIX</b> .....	<b>E-40</b>
	Flow chart: flow rate / speed / diameter (l/min, size in mm and m/sec) .....	E-40
	Flow chart: flow rate / speed / diameter (US gallon / min, size in inches and feet/sec) .....	E-41

Dear Customer,

Congratulations on having purchasing of our type 8025 batch controller.

**BEFORE INSTALLING OR USING THIS PRODUCT, PLEASE TAKE OUR ADVICE AND READ THE ENTIRE MANUAL THOROUGHLY.**

This will enable you to fully profit from all of the advantages offered by this product.

## 1.1 Unpacking and Control

Please verify that the product is complete and free from any damage. The standard delivery must include:

- 1 8025 digital batch controller, either in compact version, or in panel version with mounting accessories (1 gasket, 4 spacer bolts, 1 protective plate, 4 screws, 4 lockwashers, 2 cable clips and 1 cut-away film), or in IP65 wall-mounted version.
- 1 Manual 8025 batch controller
- 1 Manual Fitting S020/1500/1501

Compare the Type specifications on the label to the adjacent list to ensure that you have received the proper unit. If there is any loss or damage, please contact your local Bürkert subsidiary.

## 1.2 About this Manual

This manual does not contain any warranty statement. Please refer to our general terms of sale and delivery.

Only properly-trained staff should install and/or repair this product. If difficulties should occur at the time of installation, please contact your nearest Bürkert sales office for assistance.

## 1.3 User's Responsibility for Safety

Bürkert manufactures a broad range of batch controllers. While each of these products is designed to operate in a wide variety of applications, it is the user's responsibility to select a transmitter model that is appropriate for the application, install it properly, and maintain all components. Special attention must be paid to the chemical resistance of the transmitter against the fluids which are directly contacting the product.



This symbol appears in the manual to call special attention to instructions that affect the safe installation, function and use of the product.

## 1.4 Electromagnetic compatibility

This device conforms to the EMC-Directive of the European Union 89/336/EEC. In order to comply with this directive, the wiring instructions must be followed.

## 2.1 Type designation

Product designation	Power supply	Gasket	Sensor	Connection	Order N°
<b>BATCH CONTROLLER TYPE 8025 COMPACT STANDARD TYPES</b>					
8025 Batch Controller, 2 Relays, 2 Totalizers	12-30 VDC	FPM	Hall short	2xPG 13,5	419520T
8025 Batch Controller, 2 Relays, 2 Totalizers	230 VAC	FPM	Hall short	2xPG 13,5	419521Q
<b>OTHER TYPES</b>					
8025 Batch Controller, 2 Relays, 2 Totalizers	12-30 VDC	FPM	Hall long	2xPG 13,5	419522R
8025 Batch Controller, 2 Relays, 2 Totalizers	12-30 VDC	FPM	Coil short	2xPG 13,5	419523J
8025 Batch Controller, 2 Relays, 2 Totalizers	12-30 VDC	FPM	Coil long	2xPG 13,5	419524K
8025 Batch Controller, 2 Relays, 2 Totalizers	12-30 VDC	EPDM	Hall short	2xPG 13,5	419525L
8025 Batch Controller, 2 Relays, 2 Totalizers	12-30 VDC	EPDM	Hall long	2xPG 13,5	419526M
8025 Batch Controller, 2 Relays, 2 Totalizers	12-30 VDC	EPDM	Coil short	2xPG 13,5	419527N
8025 Batch Controller, 2 Relays, 2 Totalizers	12-30 VDC	EPDM	Coil long	2xPG 13,5	419528X
8025 Batch Controller, 2 Relays, 2 Totalizers	230 VAC	FPM	Hall long	2xPG 13,5	419529Y
8025 Batch Controller, 2 Relays, 2 Totalizers	230 VAC	FPM	Coil short	2xPG 13,5	419530 V
8025 Batch Controller, 2 Relays, 2 Totalizers	230 VAC	FPM	Coil long	2xPG 13,5	419531J
8025 Batch Controller, 2 Relays, 2 Totalizers	230 VAC	EPDM	Hall short	2xPG 13,5	419532K
8025 Batch Controller, 2 Relays, 2 Totalizers	230 VAC	EPDM	Hall long	2xPG 13,5	419533L
8025 Batch Controller, 2 Relays, 2 Totalizers	230 VAC	EPDM	Coil short	2xPG 13,5	419534M
8025 Batch Controller, 2 Relays, 2 Totalizers	230 VAC	EPDM	Coil long	2xPG 13,5	419535N
<b>BATCH CONTROLLER TYPE 8025 COMPACT NORTH AMERICA STANDARD TYPES NORTH AMERICA</b>					
8025 Batch Controller, 2 Relays, 2 Totalizers	12-30 VDC	FPM	Hall short	2xG 1/2"	419545Y
8025 Batch Controller, 2 Relays, 2 Totalizers	115 VAC	FPM	Hall short	2xG 1/2"	419546Z
<b>OTHER TYPES NORTH AMERICA</b>					
8025 Batch Controller, 2 Relays, 2 Totalizers	12-30 VDC	FPM	Hall long	2xG 1/2"	419547S
8025 Batch Controller, 2 Relays, 2 Totalizers	12-30 VDC	FPM	Coil short	2xG 1/2"	419548B
8025 Batch Controller, 2 Relays, 2 Totalizers	12-30 VDC	FPM	Coil long	2xG 1/2"	419549C
8025 Batch Controller, 2 Relays, 2 Totalizers	12-30 VDC	EPDM	Hall short	2xG 1/2"	419550H
8025 Batch Controller, 2 Relays, 2 Totalizers	12-30 VDC	EPDM	Hall long	2xG 1/2"	419551W
8025 Batch Controller, 2 Relays, 2 Totalizers	12-30 VDC	EPDM	Coil short	2xG 1/2"	419552X
8025 Batch Controller, 2 Relays, 2 Totalizers	12-30 VDC	EPDM	Coil long	2xG 1/2"	419553Y
8025 Batch Controller, 2 Relays, 2 Totalizers	115 VAC	FPM	Hall long	2xG 1/2"	419554Z
8025 Batch Controller, 2 Relays, 2 Totalizers	115 VAC	FPM	Coil short	2xG 1/2"	419555S
8025 Batch Controller, 2 Relays, 2 Totalizers	115 VAC	FPM	Coil long	2xG 1/2"	419556T
8025 Batch Controller, 2 Relays, 2 Totalizers	115 VAC	EPDM	Hall short	2xG 1/2"	419557U
8025 Batch Controller, 2 Relays, 2 Totalizers	115 VAC	EPDM	Hall long	2xG 1/2"	419558D
8025 Batch Controller, 2 Relays, 2 Totalizers	115 VAC	EPDM	Coil short	2xG 1/2"	419559E
8025 Batch Controller, 2 Relays, 2 Totalizers	115 VAC	EPDM	Coil long	2xG 1/2"	419560B
<b>BATCH CONTROLLER TYPE 8025 COMPACT IN PANEL VERSION</b>					
8025 Batch Controller, 2 Relays, 2 Totalizers	12-30 VDC		8020/8030	Terminals	419536P
<b>BATCH CONTROLLER TYPE 8025 COMPACT IN WALL-MOUNTED VERSION</b>					
8025 Batch Controller, 2 Relays, 2 Totalizers	12-30 VDC		8020/8030	5xPG 9	433740D
8025 Batch Controller, 2 Relays, 2 Totalizers	230/115 VAC		8020/8030	5xPG 9	433741S

### 2.2 Construction and measuring principle

#### Construction

The compact version of the Batch Controller consists of a transducer and electronic circuitry with display facilities in a polycarbonate IP 65 module. The flow rate transducer consists of a vane positioned between ceramic bearings. The measurement signal data are fed from the connecting terminals of the electronic card via 2 PG 13.5's.

The panel version of Batch Controller consists of an electronics card mounted on a front panel. The associated flow rate transducer is an 8020/8030/8031 either in the coil version or a low power Hall effect transducer. The output signals appear on the connecting terminals of the electronic card.

The wall-mounted version of Batch Controller consists of 2 electronic cards mounted in an ABS IP 65 enclosure. The associated flow rate transducer is an 8020/8030/8031 in the coil version or a low power Hall effect transducer. The output signals appear on the connecting terminals of the electronic card via 5 PG 9 cable glands.

#### Measuring principle

The unit is positioned in a pipe in series with the valve; the unit controls the opening of the valve and measures the quantity of the fluid which flows; it also closes the valve when the pre-programmed quantity has been delivered.

The electronics circuit needs a voltage supply of 12...30 V DC. Two output relays are used to activate the valves and to initiate alarms. The following dosing and filling operations are possible:

- Local Dosing; the user enters the quantity to be metered and initiates the dosage from the keypad.
- Local Dosing with pre-set quantities. The user selects a quantity which has been pre-set and initiates the dosage from the keypad.
- Remote Control Dosing using a rotary knob (selecting a pre-set quantity) or binary data inputs.
- Dosing controlled by a PLC unit using binary data inputs.
- Automatic Dosing controlled by variation of pulse duration. The quantity of the dose is directly proportional to the duration of a pulse.

The compact and wall-mounted versions of batch controllers can be fitted with a power supply of 115/230 VAC as an option.

To ensure maximum dosage and filling accuracy, the fluid velocity must be higher than 0.3 m/s (1 ft./sec.) for a preselection counter fitted with a Hall effect flow rate Burkert sensor and higher than 0.5 m/s (1.6 ft/sec) for a coil type flow rate Burkert sensor.

If other flow sensor type are used, refer to the specific sensor measuring range.

## 2.3 Dimensions

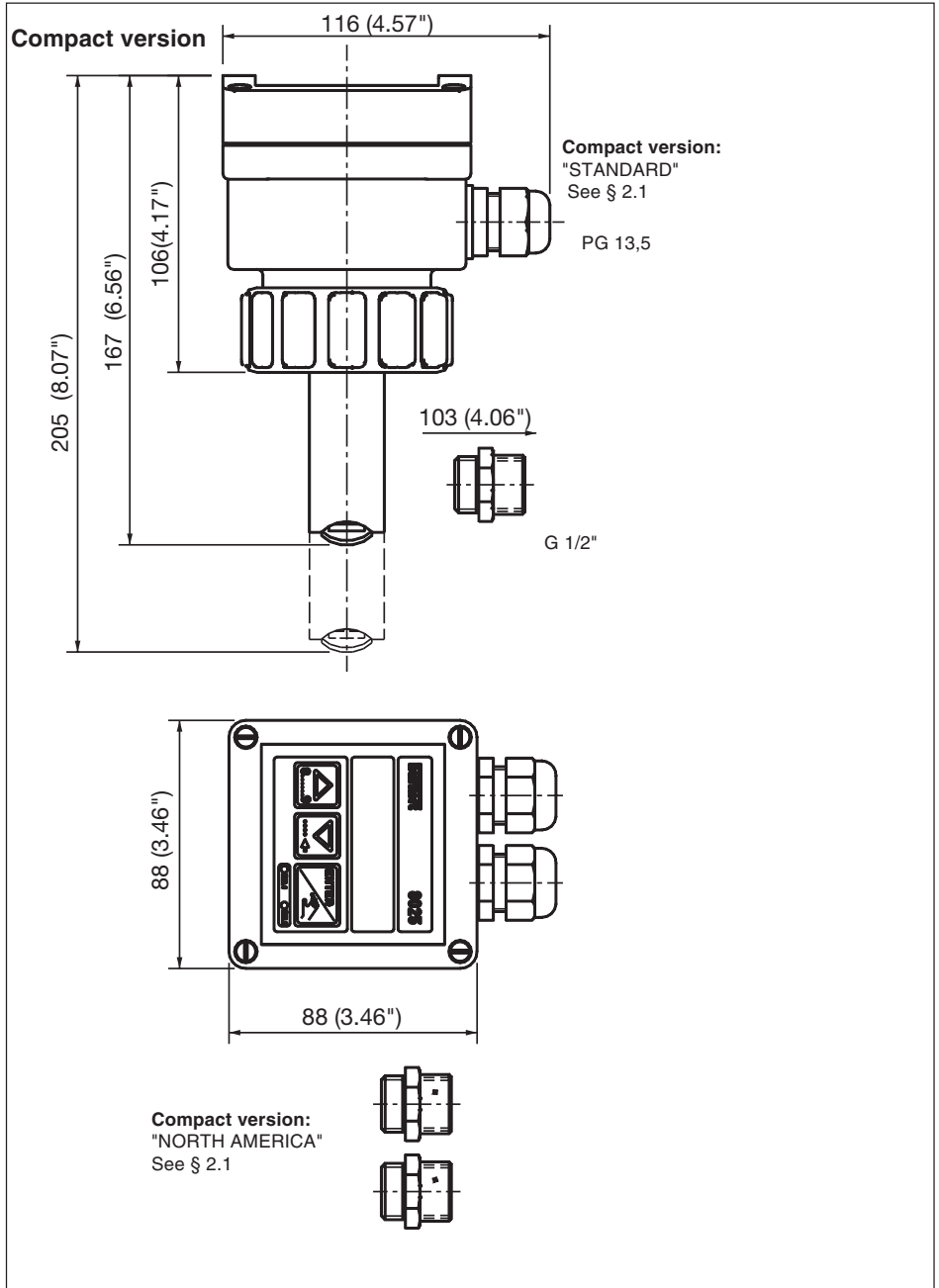

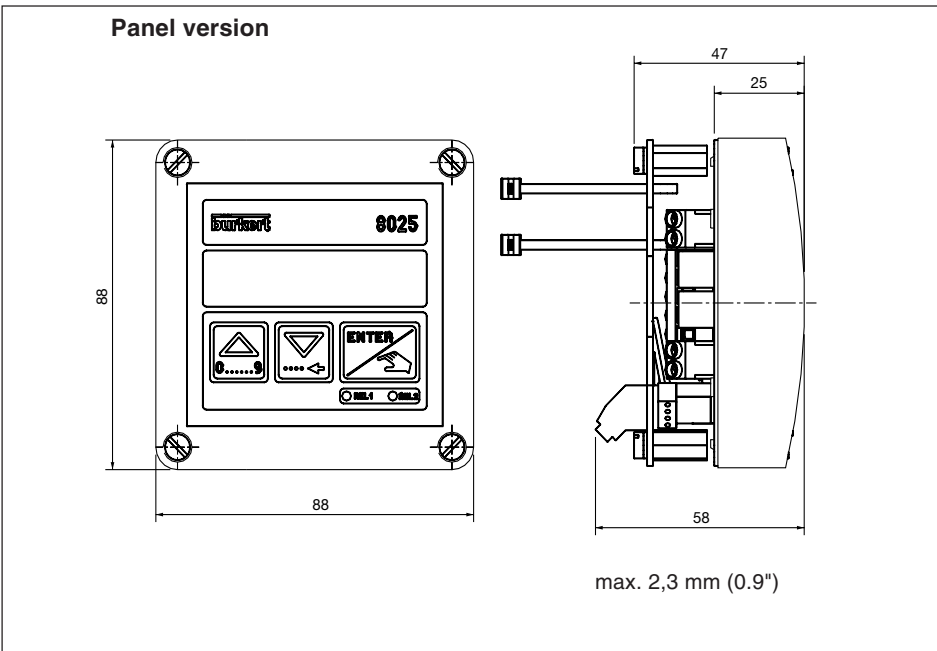
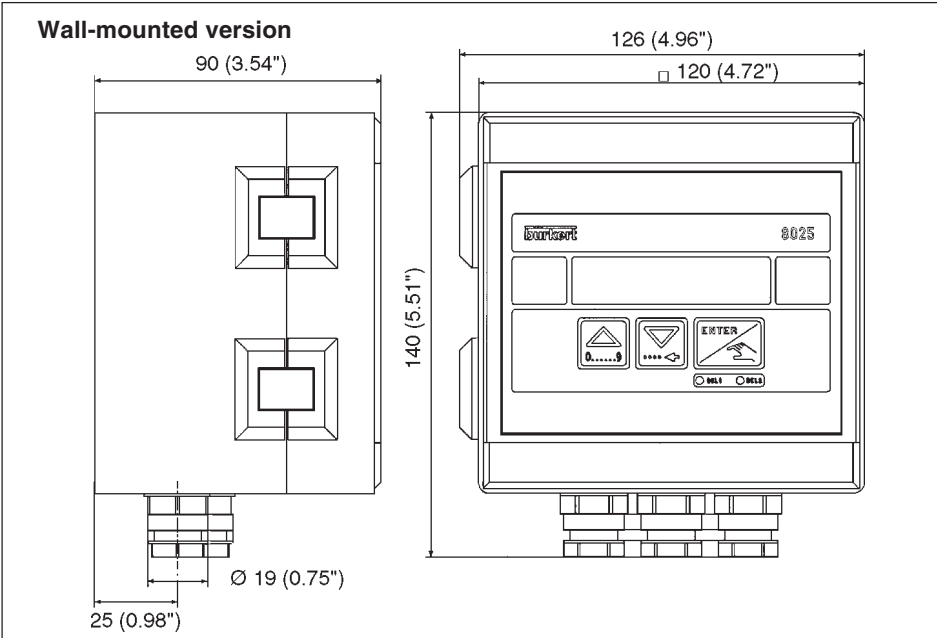

## 2.4 Technical Data

Pressure class	PN 6
Fluid T°C max. (Compact Coil version)	PVC: 50°C (122°F); PP: 80°C (176°F); PVDF: 100°C (212°F); Stainless steel and brass: 100°C (212°F)
Fluid T°C max. (Compact Hall version)	PVC: 50°C (122°F); PP: 80°C (176°F); PVDF: 80°C (176°F); Stainless steel and brass: 80°C (176°F)
Ambient temperature	0 to 60 °C (32 to 140 °F)
Storing temperature	0 to 60 °C (32 to 140 °F)
Relative humidity	80 %
Enclosure	IP65 compact, panel (outside) and wall-mounted version, IP20 panel (inside) version
Measuring range	with Hall sensor: 0.3 to 10 m/s (1.0 fps to 32.8 fps) from 3 l/min (0.8 gpm) in DN15 (1/2") pipe with Coil sensor: 0.5 to 10 m/s (1.6 to 32.8 fps) from 5 l/min (1.3 gpm) in DN15 (1/2") pipe
Measuring error	1. With In-line calibration (Teach-In): $\leq \pm 0.5\%$ o.F.S. (at 10 m/s) * 2. With standard mean K-Factor: $\leq \pm(0.5\%$ o.F.S. +2.5% o.R.) *
Linearity	$\leq \pm 0.5\%$ o.F.S. (at 10 m/s) *
Repeatability	0.4% o.R. *
Voltage supply	12...30 VDC (230 VAC power supply as option for compact and wall-mounted version)
Binary inputs	4 inputs, 5...30 VDC
Indicator lamp output	Open collector NPN and PNP, 0...30 V, 100 mA, protected
Relay output	2 relays, 3 A, 220 V, freely adjustable
Display	15 x 60 mm LCD 8 digits, alphanumeric, 15 segments, 9 mm high
Sensor housing	PVDF
Paddle-wheel	PVDF
Axis and bearing	ceramic
O-rings	FPM/EPDM
Electronics housing	PC (compact and panel version), ABS (wall-mounted version)
Front plate	polyester

\*) Under reference conditions i.e. measuring fluid water, ambient and water temperatures of 20 °C, applying the minimum inlet and outlet pipe straights, matched pipe dimensions.  
o.F.S = of Full Scale (10 m/s); o.R = of Reading

**Note:** The above characteristics are valid for compact or separate versions connected to Burkert flow sensor. If other flow sensors are used, refer to the specifications of these sensors.

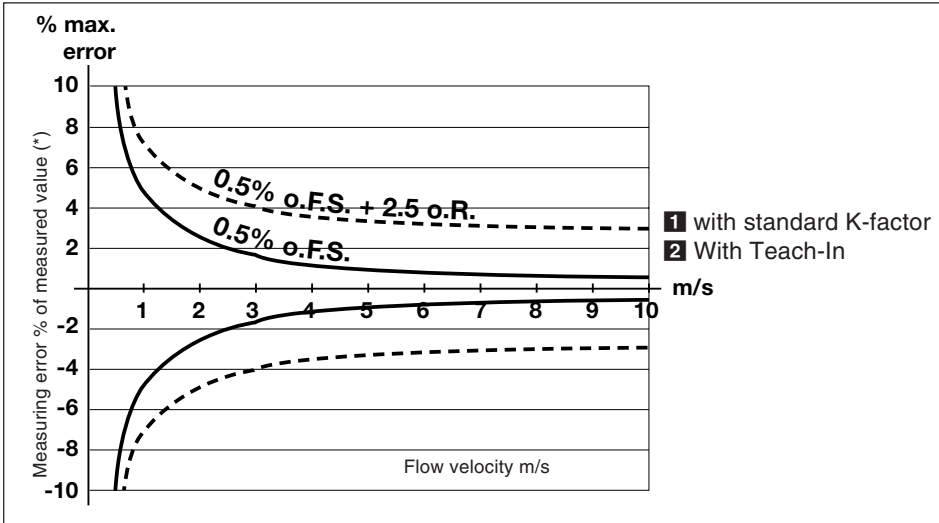

Measuring error with/without Teach-In (cf. 2.4)

3.1 Installation Guidelines

 The batch controller 8025 compact can only be used to measure pure, liquid and water resembling fluids (solids content  $\leq 1\%$ , viscosity max. 300 cSt with on-line calibration).

Installation Guidelines

The pipe must be completely filled with the fluid, i.e. air bubbles must not be present. The device must be protected against constant heat radiation and other environmental influences, such as direct exposure to sunlight or magnetic fields.

Pressure-Temperature-Diagram

Mind pressure-temperature dependence according to the respective fitting material.

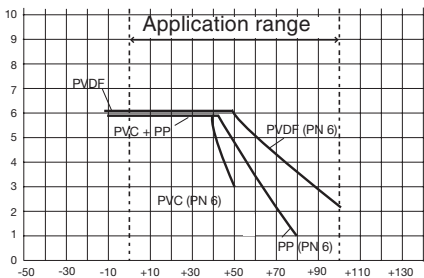

Fig. 3.1 Pressure/temperature diagram

Do not mount behind turbulence generating fittings (elbows, valves, T-pieces, etc.). The minimum upstream (10xD) and downstream distances (3xD) according to DIN must be observed.

The accuracy of the measure can be improved by increasing these values or using a flow tranquilizer.

For further information, please refer to EN ISO 5167-1.

If any other flow sensor is used, refer to the specific documentation of the sensor.



## 3.2 Installation

## Compact version (cf. fig. 3.2)

The compact batch controller type 8025 can be easily installed into pipes using our specially designed fitting system.

1. The fitting **4** must be installed into the pipe according to the installation specifications in section 3.1.
2. Insert plastic nut **3** into fitting and let plastic ring **2** snap into guide bush **5**.
3. Carefully insert batch controller 8025 **1** into fitting. If installed properly, the transmitter cannot be rotated.
4. Tighten transmitter housing to fitting with plastic nut **3**.



**Caution:** Plastic nut must only be tightened by hand!

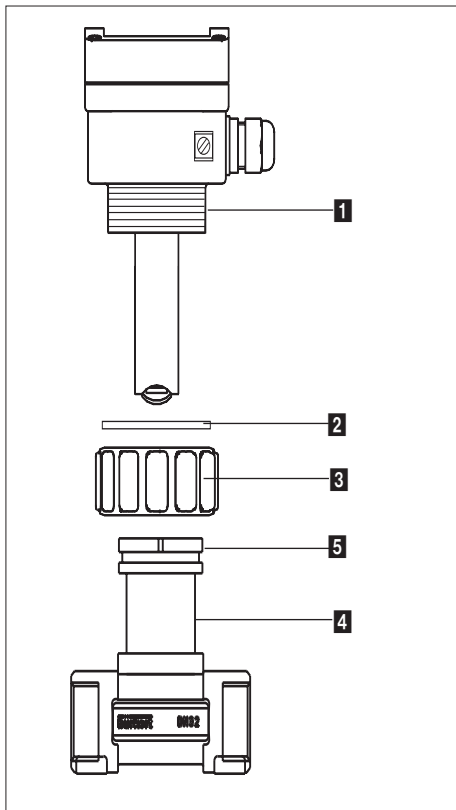
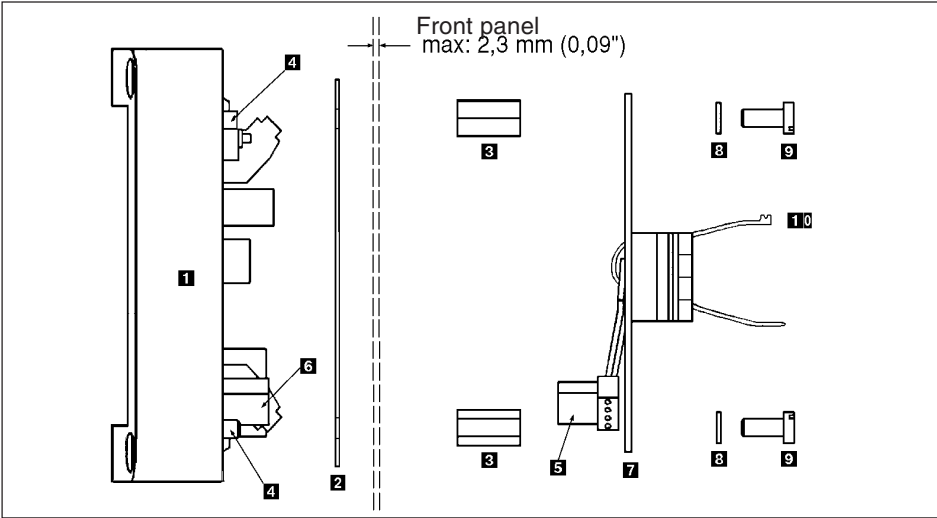

Fig. 3.2 Installation of batch controller

## Panel version (cf. fig. 3.3)

For the cut-away of the front panel, follow the instructions on the delivery enclosed film. For sensor installation, please consult 8020/8030 instruction manual. Install device as follows:

1. Put gasket **2** on the cover **1** and place the complete unit in the panel cut-away.
2. Screw the spacer bolts **3** on the panel crossing screws **4**.
3. Insert the cable clips **10**, to hold the different cables (power supply, outputs, sensor) of the batch controller, into plate **7**.
4. Plug connector **5** on socket **6** and fasten plate **7** with screws **9** on bolts **3**. Do not forget the lockwashers **8**.



**Fig. 3.3 Installation panel version**  
**Wall-mounted version (cf. fig. 3.4)**

The batch controller in wall-mounted version is equipped with 4 fixing holes in the bottom enclosure. Remove the white blanking stripes and the cover to access to fixing holes **1**. For sensor installation, please consult 8020/8030 instruction manual.

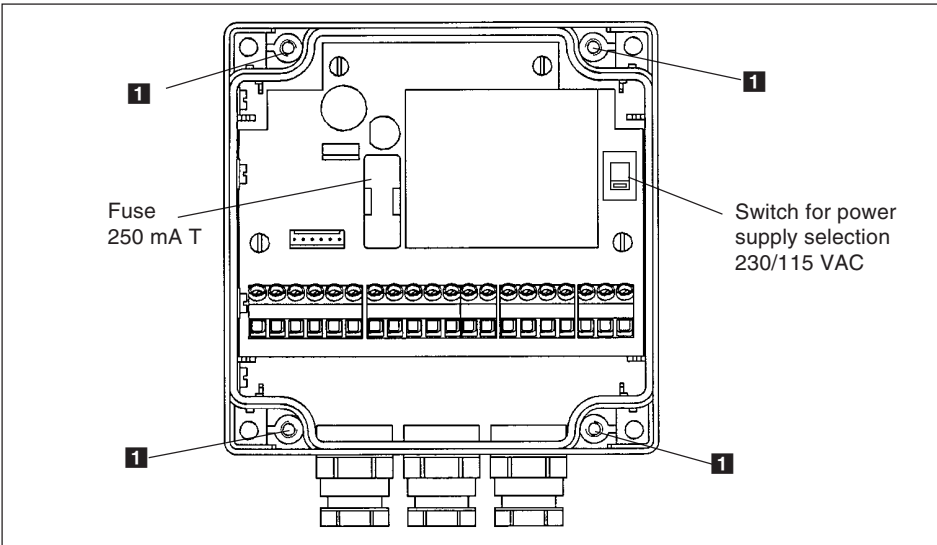

**Fig. 3.4 Installation wall-mounted  
version**

### 3.3 General Electrical Connection

The connecting line conducts the measuring signal and must not be installed in combination with high voltage or high frequency carrying lines. If a combined installation cannot be avoided, either keep a min. space of 30 cm (approx. 1 ft) or use coax cables. When using coax cables observe faultless grounding of the shield. For normal operating conditions, the measuring signal can be transmitted by a simple cable of 0.75 mm<sup>2</sup> cross section. Always use a coax cable in case of doubt.

The power supply must be of good quality (filtrated and regulated).



**Note:** For EMC purposes, the earth must be connected via the earth lug on the side of the enclosure (cf. fig. 3.2). This point must be connected locally to a good earth.

### 3.4 Electrical connection compact version

The connections are made via the two 13,5 cable glands.

Remove cover, pull cable through PG 13.5 and wire according to following pin assignment and fig. 3.5:

- 1: Binary input 1
- 2: Binary input 2
- 3: Binary input 3
- 4: Binary input 4
- 5: Indicator lamp output (Transistor Open Collector)
- 6: Common (binary inputs and outputs)
- 7: L+ (12...30 VDC)
- 8: L-
- 9: Earth
- 10: Relais 2
- 11: Relais 2
- 12: Relais 1
- 13: Relais 1

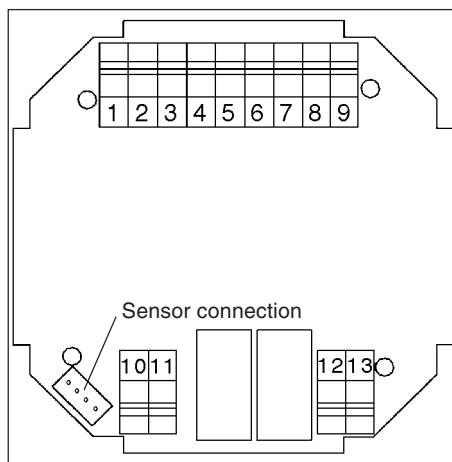
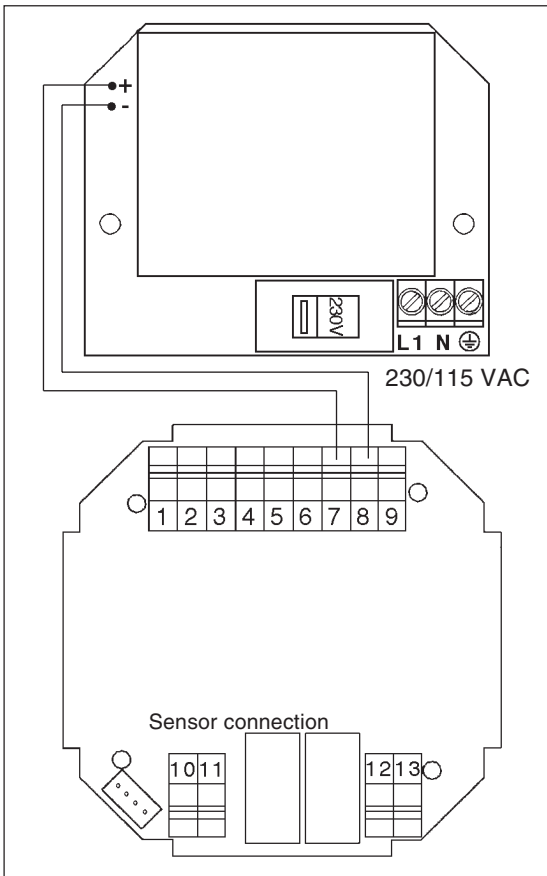

Fig. 3.5 Pin assignment

**Note:** The driver unit supply voltage can be used for the binary inputs and the indicator lamp output (open collector). In this case the common terminal (6) and the L- terminal (8) should be connected together.

## 3.5. Electrical Connections for a Supply Voltage of 230/115 VAC (option)

Remove the cover from the unit. The power supply card is in the bottom of the housing. Pull the cable through a PG 13.5 gland and make connections according to fig. 3.6. The other connections will be the same as on the standard version.



**Fig. 3.6 Connection Diagram for 230 V /115 V AC Supply voltage**



**Important:** In this version it is not possible to use the driver unit power supply for the binary data inputs and the indicator lamp output (open collector).

## 3.6 Electrical connection for panel version

Refer to § 3.4 for power supply and output connections of the 8025 in panel version.

**Note:** The driver unit supply voltage can be used for the binary data inputs and the indicator lamp output (open collector). In this case the common terminal (6) and the L- terminal (8) should be connected together.

### 3.6.1 Connection of flow sensors type 8020/8030

The 8020/8030 transducer is connected as shown in the fig. 3.7.

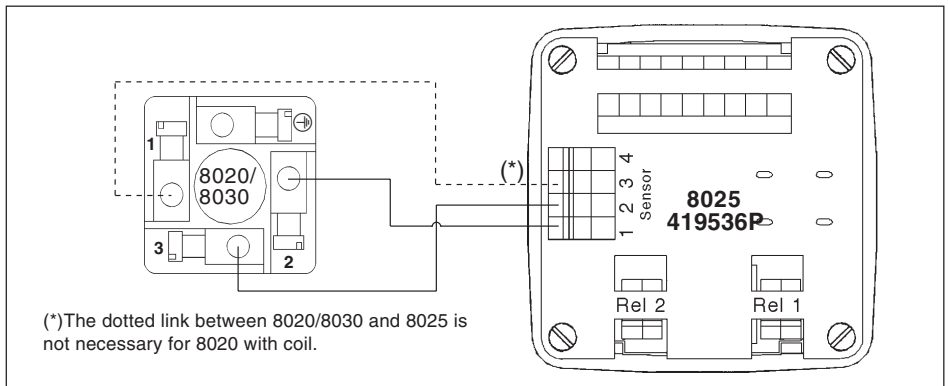

**Fig. 3.7 Connection of the flow sensor type 8020/8030 to the 8025 panel version**

### 3.6.2 Connection of flow sensor type 8031 "Low Flow"

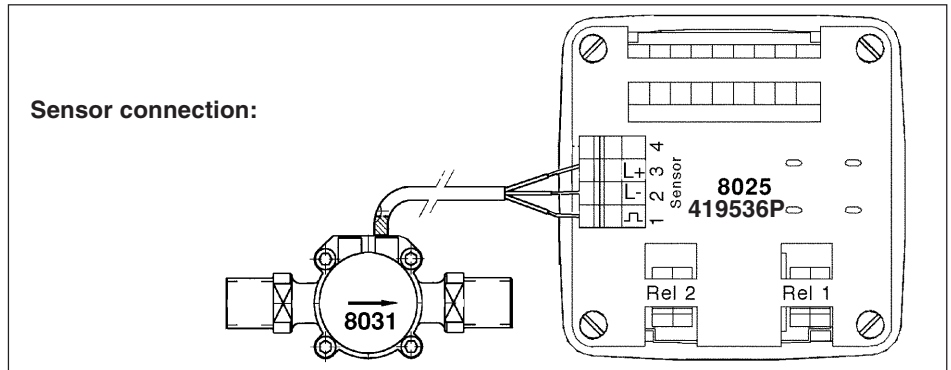

**Fig. 3.8 Connection of the flow sensor type 8031 to the 8025 panel version**

Refer to the flow sensor documentation in order to select the required voltage supply. The terminal 3 is L+ of the controller (12 to 30 V); the terminal 4 is (L+)-12 V of the controller (0 to 18 V). Connect the terminals 2 (L-) and 4 (L+) for a 5...18 VDC voltage supply of the sensor, or, connect the terminals 2 (L-) and 3 (L+) of the flow controller for a 12...30 VDC voltage supply of the flow sensor.

## 3.6.3 Connection of specific flow sensors (other than 8020/8030)

Refer to the flow sensor documentation in order to select the required voltage supply. The terminal 3 is L+ of the controller (12 to 30 V); the terminal 4 is (L+)-12 V of the controller (0 to 18 V). Connect the terminals 2 (L-) and 4 (L+) for a 5...18 VDC voltage supply of the sensor, or, connect the terminals 2 (L-) and 3 (L+) of the flow controller for a 12...30 VDC voltage supply of the flow sensor.

For power supply and output signal connection see fig. 3.7 § 3.6.1.

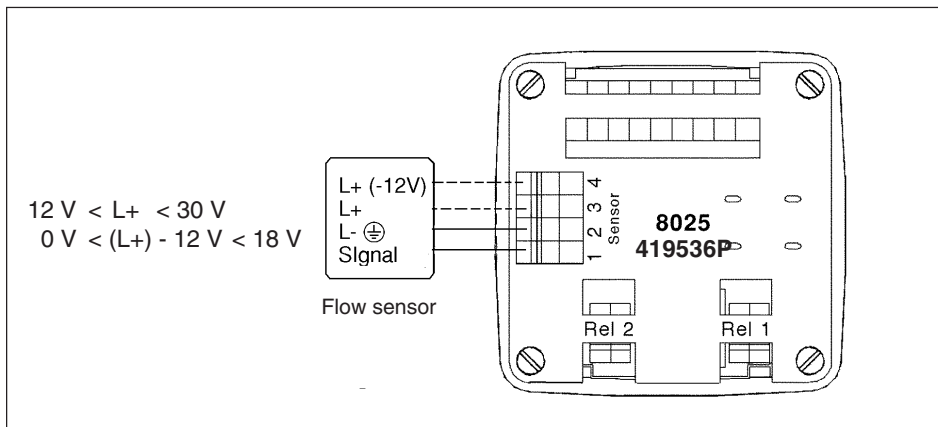

**Fig. 3.9 Electrical connection of specific flow sensors for panel version**

### 3.7. Electrical connection 8025 batch controller wall-mounted version

To obtain access to the terminals, open the cover. Make connections in accordance with the following sketches.

**Note:** The driver unit supply voltage can be used for the binary data inputs and the indicator lamp output (open collector). In this case the common terminal (10) and the L-terminal (12) should be connected together.

#### 3.7.1 Connection of flow sensors type 8020/8030

The 8020/8030 transducer is connected as shown in the fig. 3.10

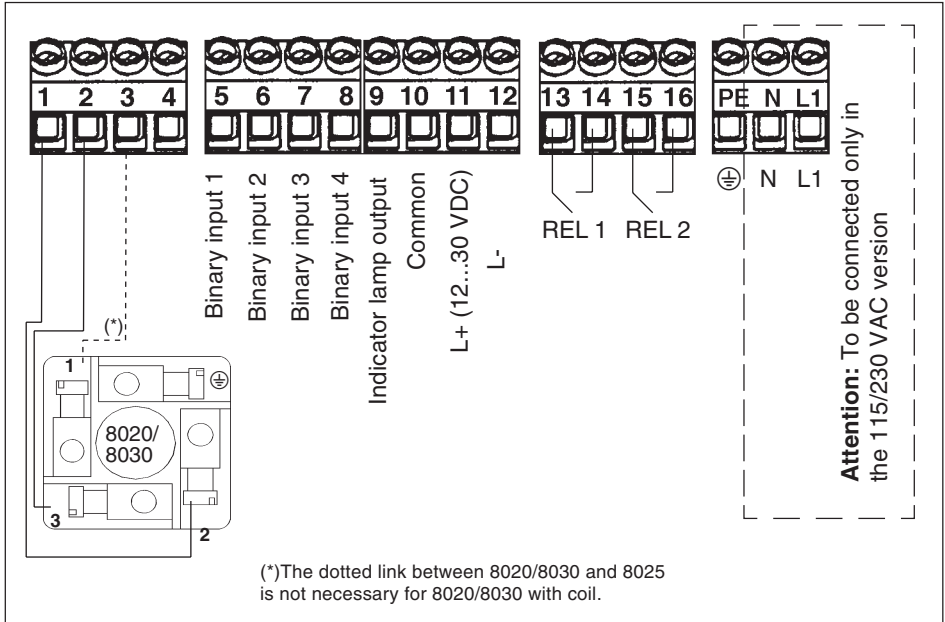

Fig. 3.10 Electrical connection for wall-mounted version

#### 3.7.2 Connection of flow sensor type 8031 "Low Flow" (cf. fig. 3.11)

Refer to the flow sensor documentation in order to select the required voltage supply. For power supply and output signal connection cf. fig. 3.10 § 3.7.1

##### with 12...30 VDC power supply of the controller

The flow sensor may be powered with 5...18 VDC, connect terminals 2 (L-) and 4 (L+) or with 12...30 VDC, connect terminals 2 (L-) and 3 (L+).

##### with 230/115 VAC power supply of the controller

The flow sensor may be powered with 16 VDC, connect terminals 2 (L-) and 4 (L+) or with 28 VDC, connect terminals 2 (L-) and 3 (L+).

If the power supply of the sensor is less than 16 VDC, the direct connection of a flow controller with 115/230 VAC power supply is not possible.

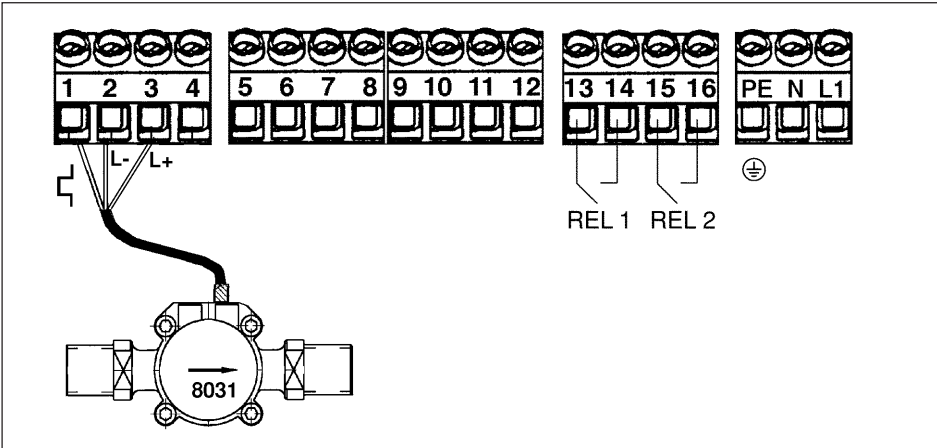

Fig. 3.11 Connection of the flow sensor type 8031 to the 8025 panel version

3.7.3 Connection of specific flow sensors (other than 8020/8030)

Refer to the flow sensor documentation in order to select the required voltage supply.

For power supply and output signal connection cf. fig. 3.10 § 3.7.1

**with 12...30 VDC power supply of the controller**

The flow sensor may be powered with 5...18 VDC, connect terminals 2 (L-) and 4 (L+)

or with 12...30 VDC, connect terminals 2 (L-) and 3 (L+).

**with 230/115 VAC power supply of the controller**

The flow sensor may be powered with 16 VDC, connect terminals 2 (L-) and 4 (L+)

or with 28 VDC, connect terminals 2 (L-) and 3 (L+).

If the power supply of the sensor is less than 16 VDC, the direct connection of a flow controller with 115/230 VAC power supply is not possible.

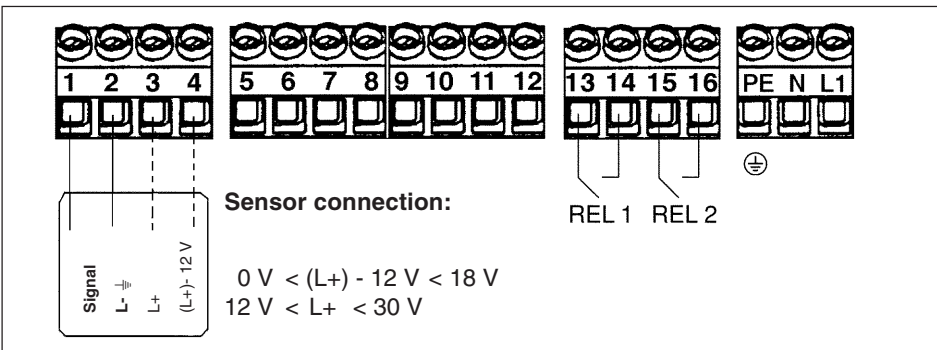

Fig. 3.12 Connection of the specific flow sensor to the 8025 panel version



Programming is carried out using three menus and is the same for all versions of the equipment (compact, panel and wall mount).

## Main menu

Using this menu the user can control the dosing using the keypad (start, pause, reset, stop); using a readout, he can monitor the flow rate and the initial preset quantity throughout the dosage operation. The readings of the main counter and the daily counter are displayed in this menu. The daily counter can be set to zero.

## Calibration Menu

This menu enables the setting of the dosage parameters (language, measurement units, equipment, K factor, dosage option, overflow correction, alarm and relay thresholds). Simultaneous resetting of the two counters is carried out in this menu.

## Test Menu

This menu enables the user to check the binary inputs (remote control) and to simulate the operation of the relays.

It also caters for measuring the rotation frequency of the paddle wheel (Hall effect or coil)

## 4.1 Description of Dosage Options

Dosage options are selected in the «*OPTION*» sub-menu of the Calibration Menu. (see § 4.4.4.)

### 4.1.1. «*LOC.MANU*» Option»

When this option is selected, the prompt «*BATCH M*» is displayed in the main menu. It enables the generation of a dose quantity which can be defined using the keypad. (see § 4.3.1.)

### 4.1.2. «*LOC.MEM*» Option

When this option is selected, the prompt «*BATCH A*» is displayed in the main menu. This option enables the generation of a dose quantity which has already been entered into the memory (7 in total) from the keypad (see § 4.3.2.).

### 4.1.3.»*MEM+MANU*» Option

When this option is selected, the prompts «*BATCH M*» and «*BATCH A*» are displayed in the main menu. This option enables the generation of a dose quantity either manually or automatically. (see § 4.3.1. and § 4.3.2.).

## 4.1.4. «EXT.MEM» Option

This option enables the generation of a dose quantity which has already been entered into the memory (7 in total) from a remote position by using the binary data inputs (See § 4.2.2.). The following example describes the various methods of connection.

Example: Connection to a PLC (compact version)

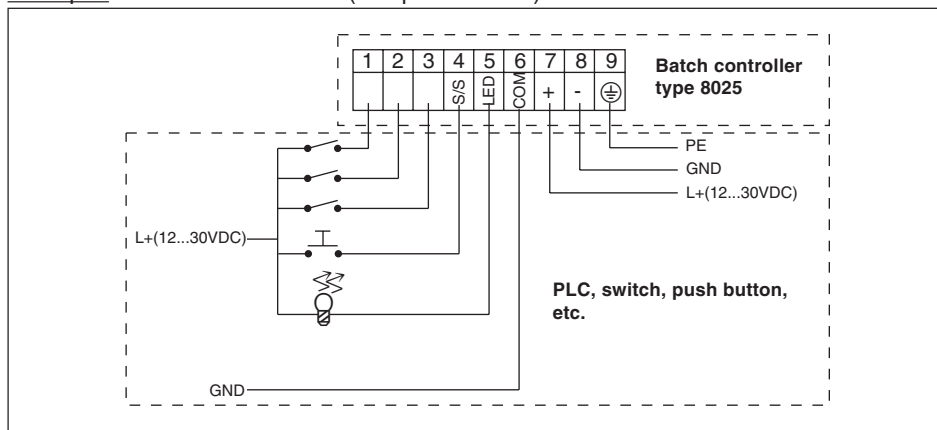

The selection of a dose quantity from the memory (V1 to V7) is carried out by encoding the binary data at inputs 1, 2 and 3. The following table shows the logic value at each input to provide each of the desired seven quantities:

Volume	V1	V2	V3	V4	V5	V6	V7
Input 1	1	0	1	0	1	0	1
Input 2	0	1	1	0	0	1	1
Input 3	0	0	0	1	1	1	1

1: Input enabled (switch closed)

0: Input disabled (switch open)

Binary Data Input 4 provides the start / pause function (from a push button, for example).

Output 5 is a transistor output (open collector) which provides Batch Controller status information. For example, it can be used to feed an indicator lamp. The following status conditions can be indicated:

Lamp OFF

Lamp lit

Slow flashing (1 Hz)

Rapid flashing (3.5 Hz)

N° dosing in progress

Dosing in progress

Pause in dosing operation

Alarm (problem during dosing operation)

**4.1.5. «EXT. [T]» Option**

This option enables the generation of a dose quantity which is proportional to the time duration during which binary data input 1 is enabled (see § 4.3.3.). The proportional relationship is as follows:

**Dose Quantity (Volume) = (A x t) +B** where A is the coefficient of proportionality  
 B is the offset  
 t is the input 1 activation time

Coefficients A and B have to be entered by the user.

**Pulse specification**

T <sub>min</sub> :	100 msec
T <sub>max</sub> :	300 sec
Definition:	5msec
Minimum time between 2 contiguous pulses:	100 msec

Practical examples:

- Filling of cans of 5, 10 and 50 litres respectively. The following values can be entered:

A = 5 l/s  
 B = 0 l

The activation times for binary data input 1 for the three volumes are as follows:

Volume (l)	5	10	50
Duration (s)	1	2	10

- Doses of chemical products as a function of required concentration. Volumes of 110, 120, 130, and 150 litres. The following values can be entered:

A = 5 l/s  
 B = 100 l

The activation times for binary data input 1 for the three volumes are as follows:

Volume (l)	110	120	130	150
Duration (s)	2	4	6	10

**Notes:**

- The activation time for the binary data input must always be lower than the actual filling time. A margin of safety should be allowed when choosing the coefficients A and B.
- The coefficients A and B should be chosen such that the activation times for the binary data input should be realistic. In the second example, one could have chosen A = 100 l/s and B = 0 l. The resulting activation times would be 1.1, 1.2, 1.3 and 1.5 seconds. In this instance the doses would be less accurate.

4.2 Set-up keys for the batch controller

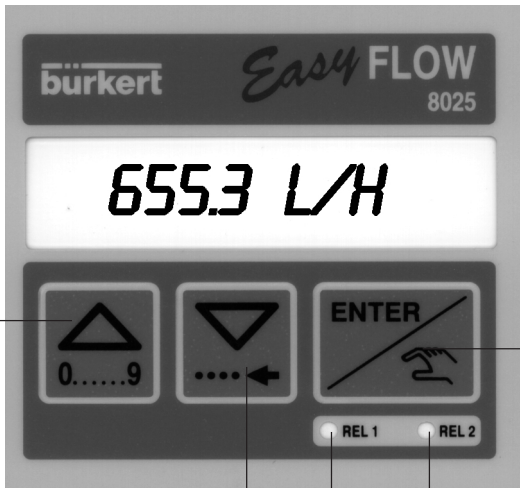

Selection key  
(menu option)  
Incrementing key  
(for numeric values)

Enabling Key  
(parameters and menu  
options).  
Dosage Start  
Dosage Pause

Selection key  
(Change digit,  
menu option).  
Readout of flow rate and  
initial preset quantity during  
dosage.

Relay 2: contact closed

Relay 1: contact closed

## 4.3 Main menu

In the main menu, following readouts are available:

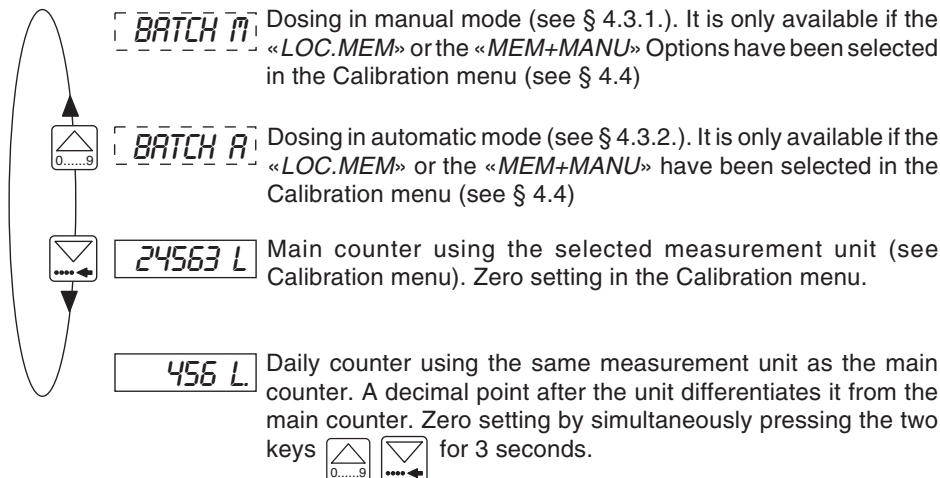

The following sub-routines describe the various dosage options together with the prompts displayed in the main menu. The characters in grey flash when displayed.

### 4.3.1. Dosage in manual mode «*LOC.MEM*» or «*MEM+MANU*» Options

This mode enables the generation of a dose quantity which has already been entered from the keypad.

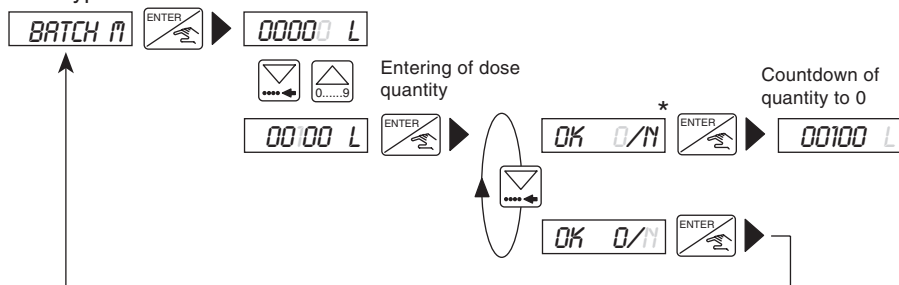

\* You can also start the dosage using the 'Start/Pause' Binary Data Input (see 4.1.4).

The dose quantity must be greater than 0.2 times the K factor (in litres). The entry of a zero quantity forces a return to the «*BATCH M*» option.

The «*ALARM*» prompt during a dosing operation signifies a dosing problem (see § 5.1). During the generation of the quantity which has been entered it is possible to display the flow rate, to pause, to reset or to stop the dosage operation. (see § 4.3.4. and § 4.3.5.).

## 4.3.2. Dosage in automatic mode («*LOC.MEM*», «*MEM+MANU*», or «*EXT.MEM*» Options)

The automatic mode enables the generation of a dose quantity from one of the 7 values already entered into the memory. The dose quantity can be initiated either from the keypad or by using the binary data inputs.

### Initiating the dosage from the keypad («*LOC.MEM*», «*MEM+MANU*» Options)

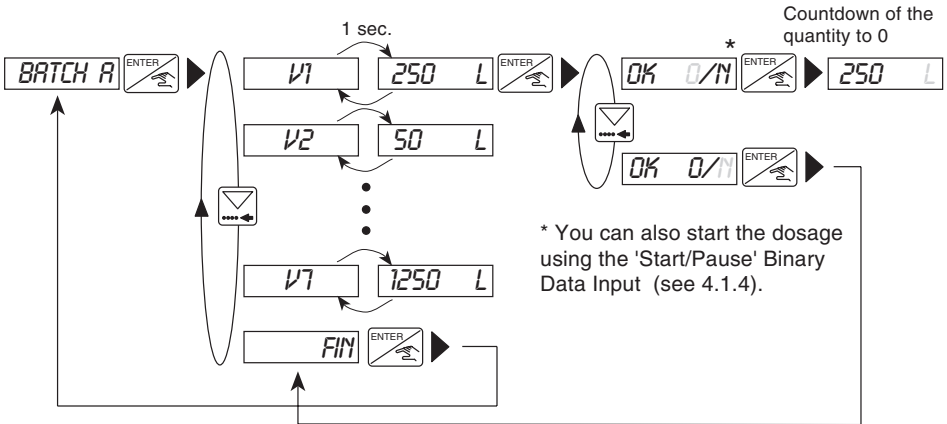

Zero quantities (from V1 to V7) will not be displayed.

### Initiating the dosage from the binary data inputs («*EXT.MEM*» Option)

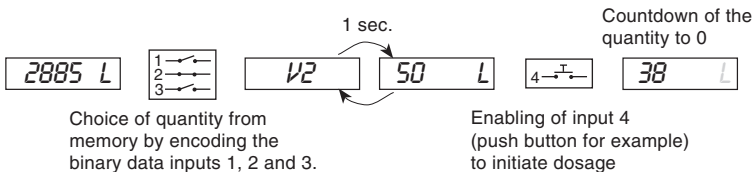

«*ALARM*» prompt during dosage operation: dosage problem (see § 5.1.)

During dosage of the selected quantity, it is possible to display the flow rate, to pause, to reset or to stop the operation (see § 4.3.4. and § 4.3.5)

### 4.3.3. Dosage proportional to a pulse duration («EXT.[T]» Option)

This option enables the initiation of a dosage quantity which is proportional to the time during which binary data input 1 is enabled. The following prompts are displayed in the principal menu during the dosage operation.

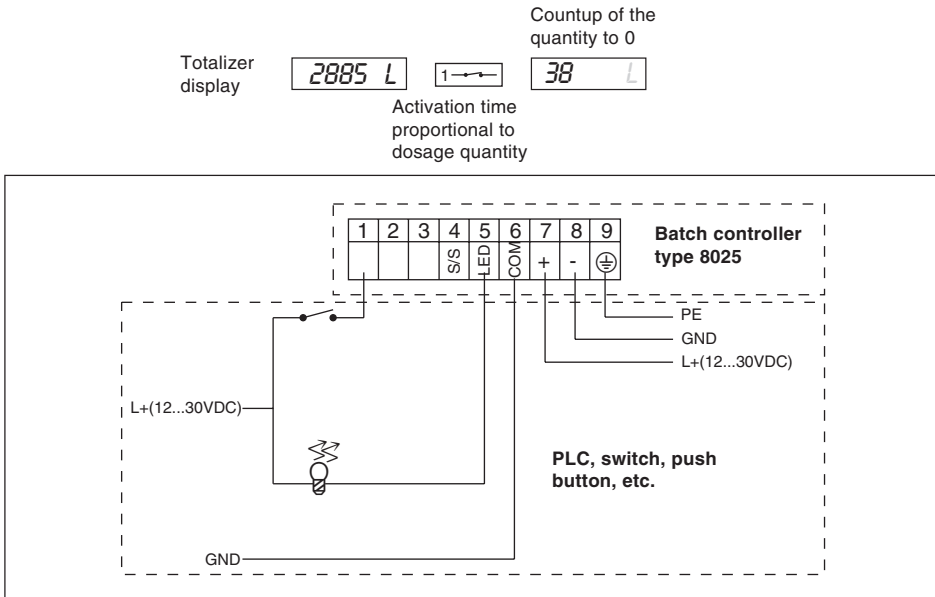

**Fig. 4.1 Example of electrical connection**

«ALARM» prompt during dosage operation: dosage problem (see § 5.1.).

During dosage of the selected quantity, it is possible to display the flow rate, to pause, to reset or to stop the operation; however, these facilities are only possible by using the keypad. (see § 4.3.4. and § 4.3.5)

### 4.3.4. Display of flow rate and the initial preset quantity during the dosage.

To display the values of the flow rate and of the initial preset quantity during the dosage operation it is only necessary to press the  key briefly. This is a useful facility irrespective of the dosage option chosen.

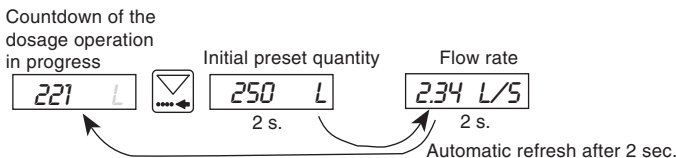

## 4.3.5. Pause / reset function

Pause and reset facilities are available during a dosage operation. It is only necessary to press the  key briefly.

Countdown of the dosage operation in progress

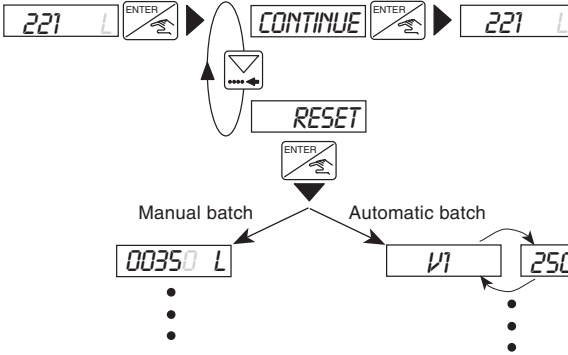

When in the «EXT.MEM.» option, it is also possible to carry out the above operations by using the binary data inputs.

Countdown of the dosage operation in progress

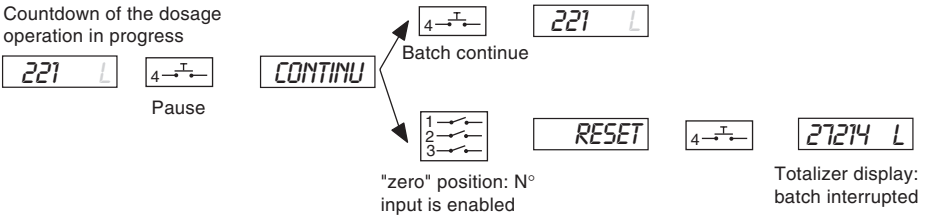



## 4.4. Calibration Menu: Simultaneous pressing for 5 seconds

In this menu, the following parameters may be set:

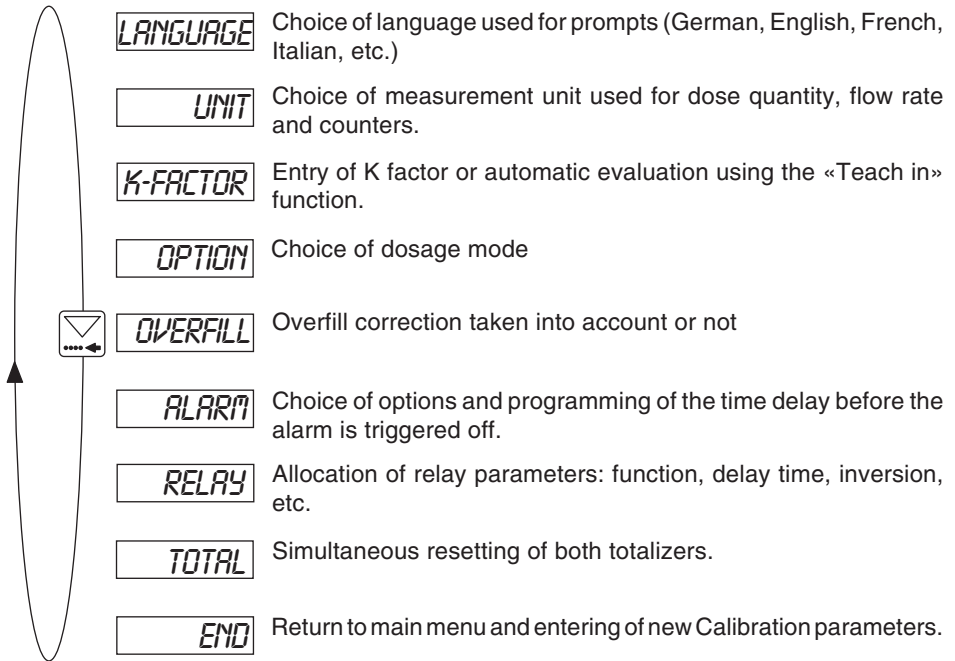

### 4.4.1 Language

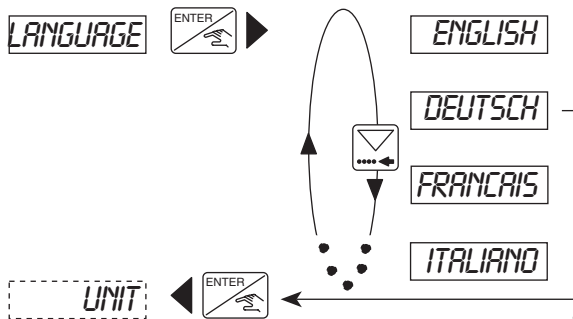

The required language becomes operational when the Enter key is pressed.

## 4.4.2 Unit

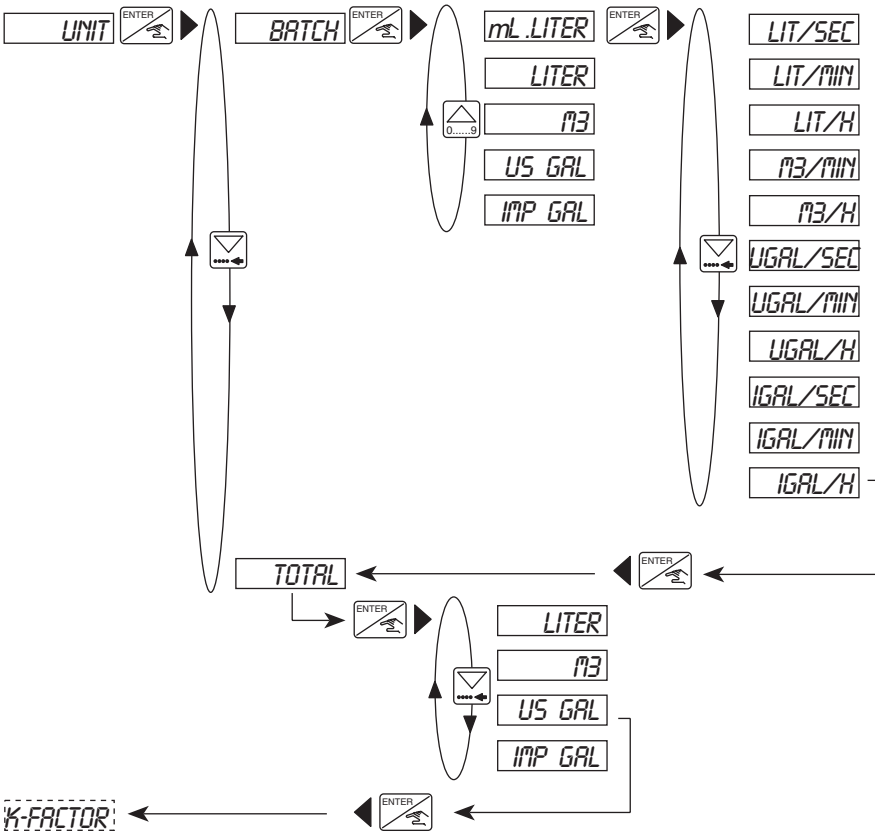

**Note:** Return to the main menu is only available from the «TOTAL» Sub-Menu.

## 4.4.3 K-factor

The K-factor of the fitting is entered in this menu (see Instruction manual fitting type S020/S0301500/1501 if a Burkert sensor is used, else, refer to the specific instruction manual of the sensor). The "Teach in" function allows to practically determine the application specific K-factor. The user only needs to run a known quantity through his system.

**Example:** In order to determine a quantity the most accurately possible, the user shall fill a tank of 100 liters. When the message "TEACH YES" appears, he presses the Enter key to start the measuring procedure. The message "FILL END" (end of filling) will appear. He then switches on a pump or opens a valve. As soon as his tank is full, he switches off the pump or closes the valve. Pressing Enter stops the measurement. The user will then be asked to enter the quantity (100 liters). The calculated K-factor is displayed after confirmation.

**Note:** The operative value of the K factor is the last one to be calculated or entered.

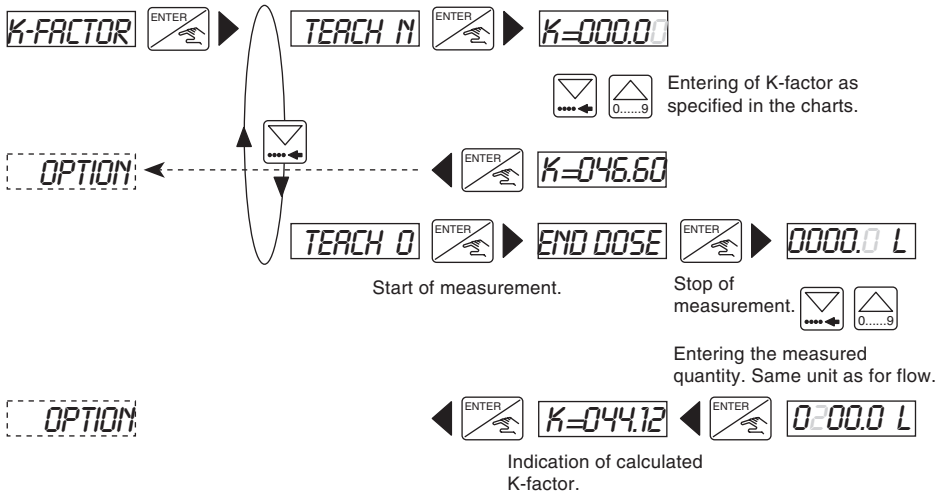

**Note:** A decimal point can be entered by simultaneously pressing keys . It will always be positioned to the right of the flashing digit. Three positions are possible, «0000.0», «0000.0» or «000.00».

*Adjustment range for the K-factor : 0.01 to 99999.*

### 4.4.4. Dosage Options

In this sub-menu, the user selects the desired dosage option from: LOC.MEM, LOC.MANU, MEM+MANU, EXT.MEM, and EXT.[T]. For more information on these options, see § 4.1.

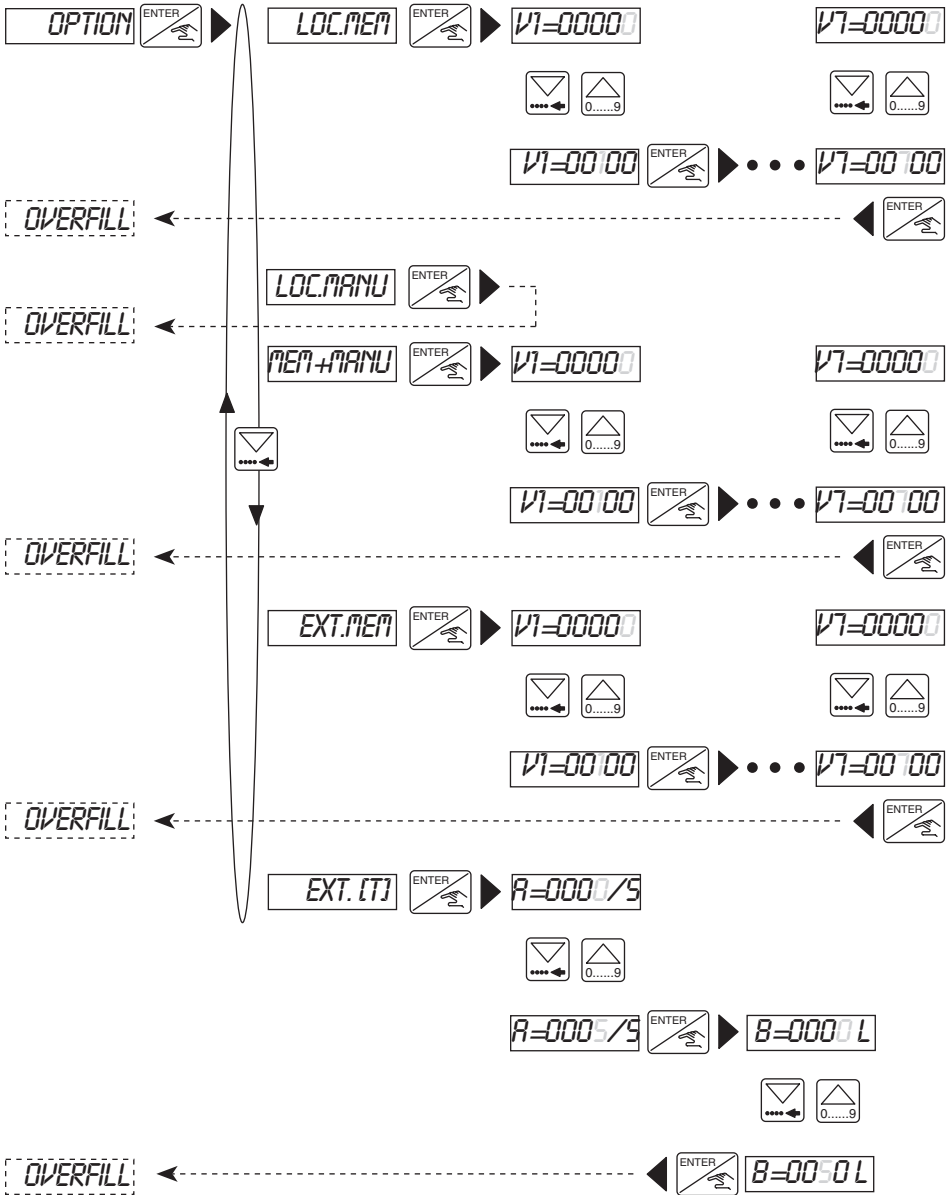

When entering volumes (quantities) V1 to V7, the measurement unit which applies is that which was selected for the dosage quantity (see Calibration Menu).

**Note:** A decimal point can be entered by simultaneously pressing keys . It will always be positioned to the right of the flashing digit.

## 4.4.5. Overfill correction

The 8025 Batch Controller has a jet correction facility. It memorises the fluid quantity which continues to flow after the closure of the valve so that it can be deducted from the following dosage. In this sub-menu the user enables or disables the jet correction facility.

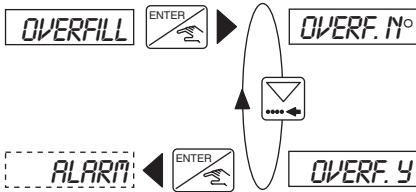

## 4.4.6 Alarm

The menu makes it possible to enable or disable the trigger-off of the alarm during a dosage (DURING option) and/or after a dosage (AFTER option). It also makes it possible to program the time delay before the alarm is triggered off, for either option. The alarm display prompt is «ALARM». This alarm data prompt is also available on tag strip terminal N°. 5 (transistor output, open collector) and on Relay N° 2 if this relay has been configured as an alarm relay (see next paragraph).

For the conditions required to trigger off the alarm, see Section 5.

*Range of adjustment: between 0 and 999 seconds.*

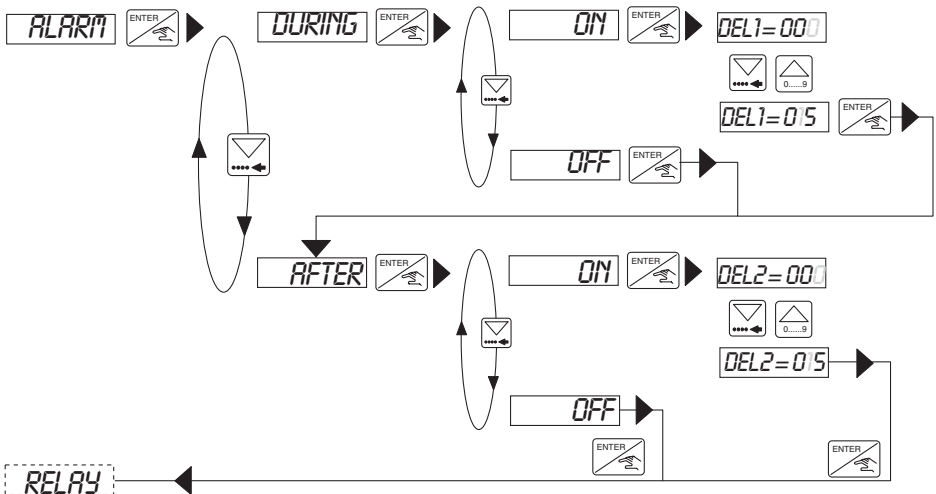

NOTE : The time delay before the alarm is triggered off must take into account the overfill correction if enabled.

### 4.4.7. Relays

There are two relays in the unit:

- Relay 1 only controls the opening of the main valve (high flow rate). A time delay before activation may be fixed and the operating polarity may be inverted; the user also has the facility of setting the percentage of the dosage quantity to be delivered through the main valve (high flow rate). This latter facility implies that Relay 2 controls an auxiliary valve (low flow rate) in order to provide the remainder of the quantity which was initially set.
- Relay 2 can be configured for three different functions: Alarm, end of dosage and control of an auxiliary valve. In each configuration the operating polarity can be inverted.

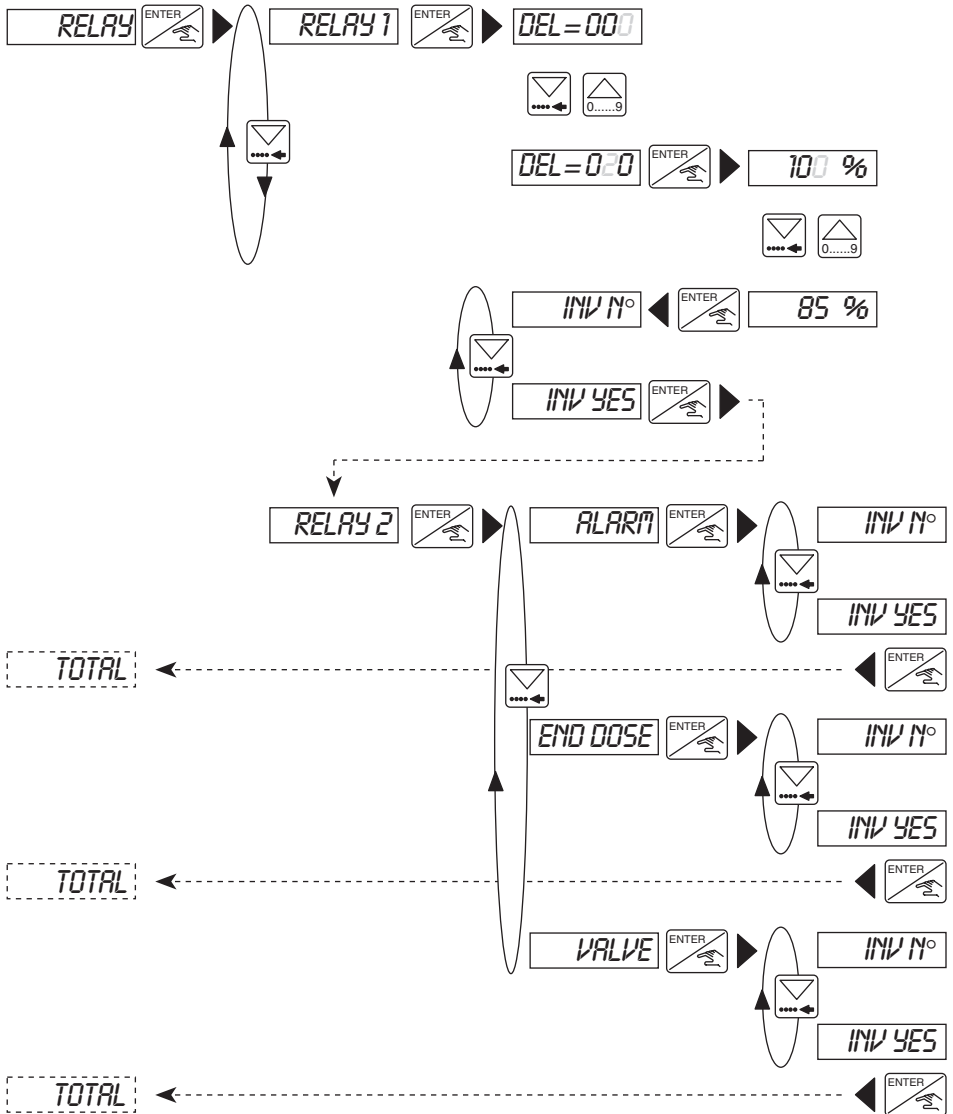

### Notes:

- If Relay 1 is configured for a percentage flow rate which is different from 100, then Relay 2 will automatically be configured for valve control. The other options will N° longer be available.
- Relay 1 will not open the valve until the entered time delay period has elapsed.

## 4.4.8 Totalizer

Simultaneous setting of both counters to zero. This facility becomes operational when the user presses the Enter key while in the «END» option in the Calibration menu.

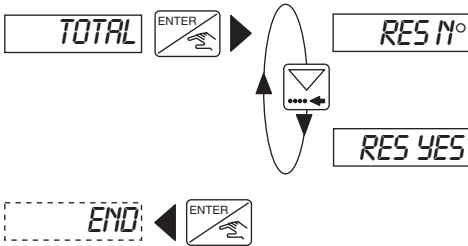

## 4.5 Test Menu: simultaneously for 5 s.

The following adjustments and checks are carried out in the Test Menu:

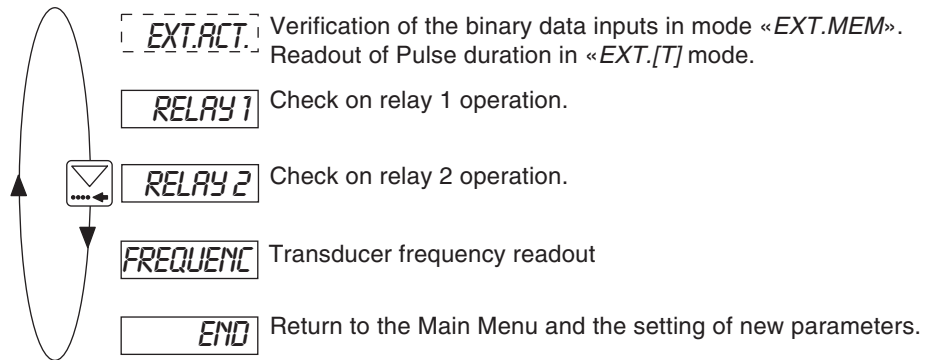

### 4.5.1 EXT.ACT.

This sub-menu provides for checking the allocation of binary logic levels to the binary data inputs under the «EXT.MEM» dosage option and also provides a readout of the pulse duration under option «EXT [T]».

#### «EXT.MEM» Option



Readout of quantities corresponding to the coding of the binary inputs (by using the rotary knob, for example). If the readout shows «--» the coding of the inputs corresponds to a zero quantity.



## «EXT. [T] Option

In this option, the user can check the pulse duration being sent to the Batch controller.



### 4.5.2. Check on operation of relays

This option allows the operator to check for correct operation of the relays by using the keypad to energise the relays.

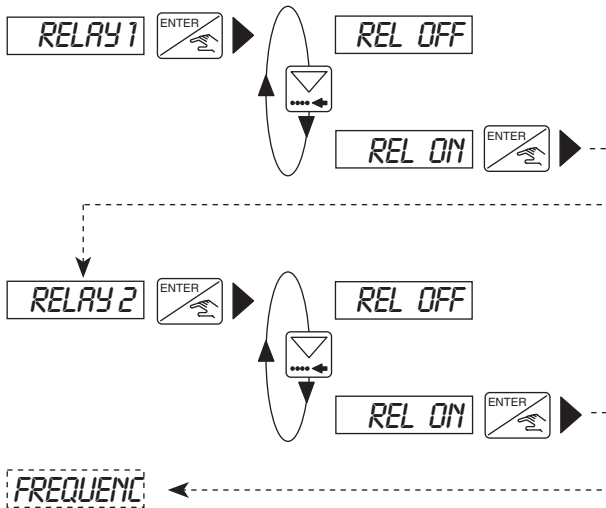

### 4.5.3. Frequency readout

Readout of vane rotation frequency. To clear the display and proceed to the next option, press on the Enter key.



**Note:** After the display of the «FREQUENC» prompt, pressing on the Enter key will energise Relay 1 (to open the valve).

## 5.1 Fault prompts

### 5.1.1. «ALARM» prompt

The «ALARM» prompt will be displayed during a dosage operation (irrespective of the dosage option) if one or both valves are open and if the controller detects a N° flow condition. The time delay before triggering the alarm is set in the Calibration menu. (see § 4.4.6)

The «ALARM» prompt will be displayed at the end of a dosage operation (irrespective of the dosage option) if one or both valves are closed and if the controller detects that there is still a flow condition after the time delay period before alarm triggering has elapsed.

**Note:** The alarm time delay must take account of any jet correction that may have been entered (the fluid quantity which continues to flow after the closure of the valve).

A dosage that has been stopped by the alarm can either be continued or cancelled:

- Manual or automatic dosage activated by *LOC.MANU*, *LOC.MEM* or *MEM+MANU* :

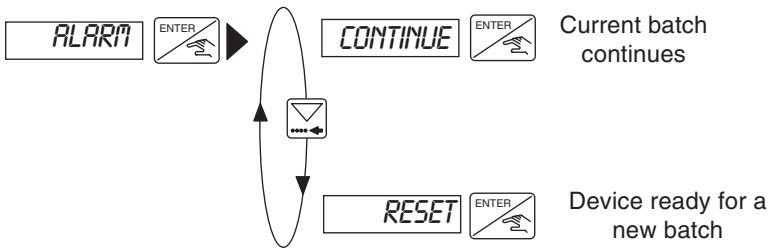

- Dosage through Binary Inputs and activated by *EXT.MEM* :

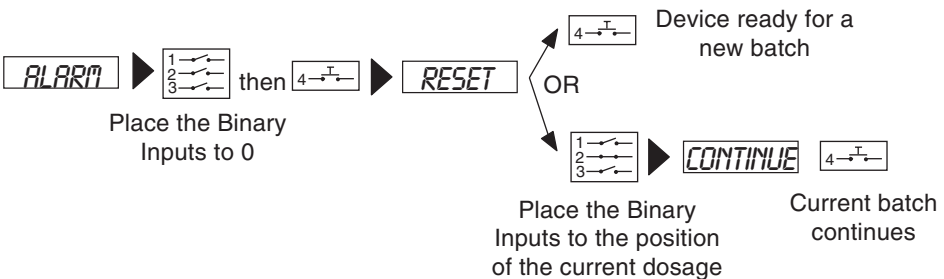

**5.1.2. «[T] ERROR» prompt**

This error prompt only occurs in the «EXT.[T]» option. It is displayed during a dosage operation if the duration of the pulse is greater than 300 seconds or if it is greater than the duration necessary to deliver the relevant quantity.

It will also appear when the quantity to be delivered is greater than 100000 (l, m<sup>3</sup>, etc.) or if the quantity being delivered has reached 100000 (l, m<sup>3</sup>, etc.) and when the pulse has not been switched off.

**5.1.3. «ERROR» prompt**

If the «ERROR» prompt appears the calibration parameter values have been lost. After pressing the Enter key, the Main Menu appears but the unit will be in the basic default configuration (see § 5.3). It will be necessary to re-programme the driver unit. If the display of this prompt becomes a recurrent phenomenon, return the unit to your supplier.

**5.2. Transducer maintenance**

Provided the installation and the operating conditions are satisfactory, the Batch Controller does not need any particular maintenance. If clogging occurs, the parts of the transducer which are immersed (vane, spindle, bearings) can be cleaned with water or any other cleaning agent suitable for use with PVDF.

**5.3 Default configuration of 8025 Batch Controller on delivery**

Language:	english	Overfill correction:	yes
Unit flow:	L/s	Alarm DURING: On, DEL1 = 100	
Unit totalizers:	L	Alarm AFTER: On, DEL2 = 100	
Unit batch:	L	Relay 1:	DEL = 000
K-Factor:	001.00		100 %
Batch option:	MEM+MANU		inversion: N°
Quantities V1 to V7:	00000	Relay 2:	VALVE
			inversion: N°

## 5.4 Spare Parts List

## Compact Version

Position	Specification	Order-N <sup>o</sup> .
1	Sensor housing with ring, union nut and 2 flat packings	419857Z
2	PG 13.5	418339Q
3	PG 13.5 USA-version (G 1/2 ")	418340M
4	Cover with screws, sheeting and printed circuit board Batch Controller	425432D
5	Power supply board 230/115 VAC	418483J
6	Ring	619205
7	Union nut	619204
8	Sensor for DN 15 to 100 (1/4" - 4") with coil	633366A
	Sensor for DN 15 to 100 (1/4" - 4") with Hall sensor	418316Z
9	Sensor for DN as from 100 (as from 5") with coil	634757B
	Sensor for DN as from 100 (as from 5") with Hall sen.	418324Z
10	FPM seal kit	425554P
	EPDM seal kit	425555Q
11	Operating instruction manual type 8025 Batch	419565U
	Operating instruction manual fitting S020/1500/1501	429633S

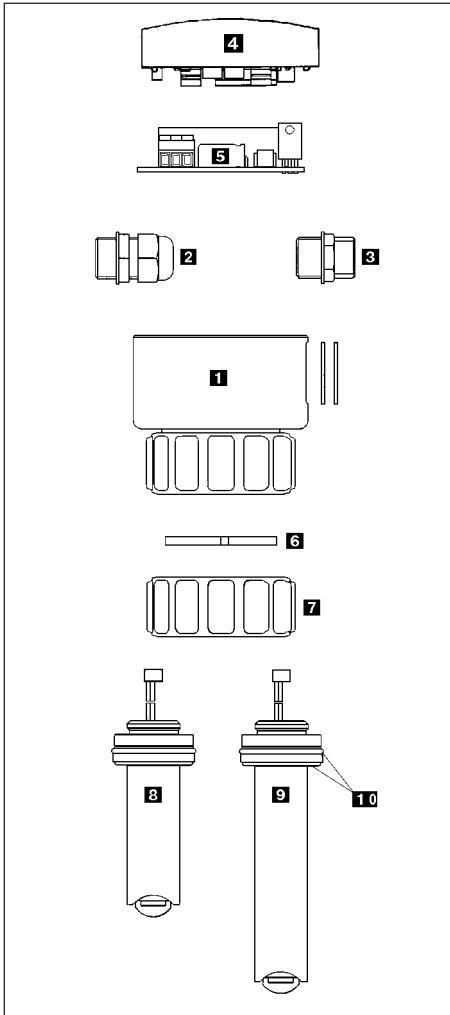

Fig. 5.1 Spare Parts Explosion Drawing 8025 Compact Version

## Panel Version

Position	Specification	Order N°
4	Identical to 8025 compact version	
11	Identical to 8025 compact version	
12	Gasket	419350Q
13	Protective plate	419779J
14	Mounting accessories (screws, lockwashers, spacer bolts, cable clips)	418388A

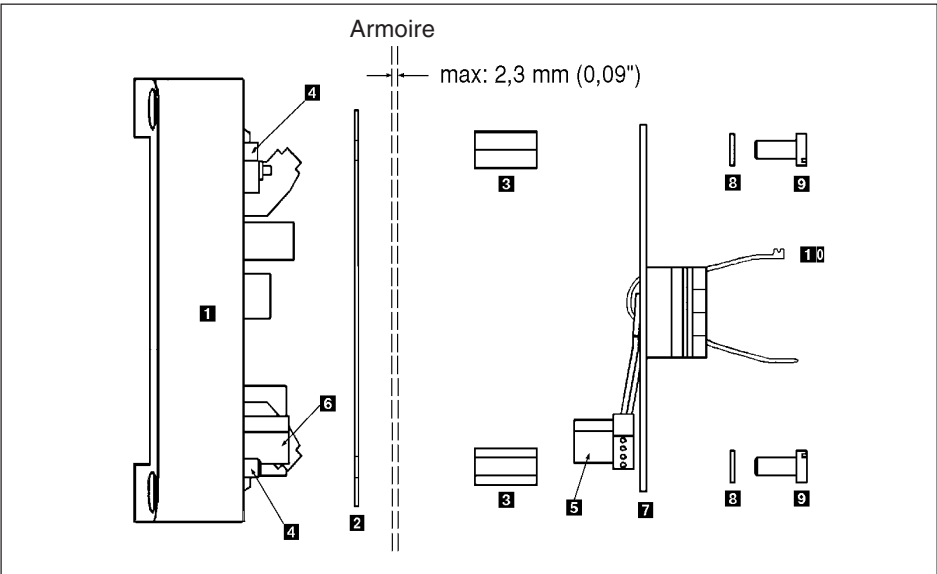
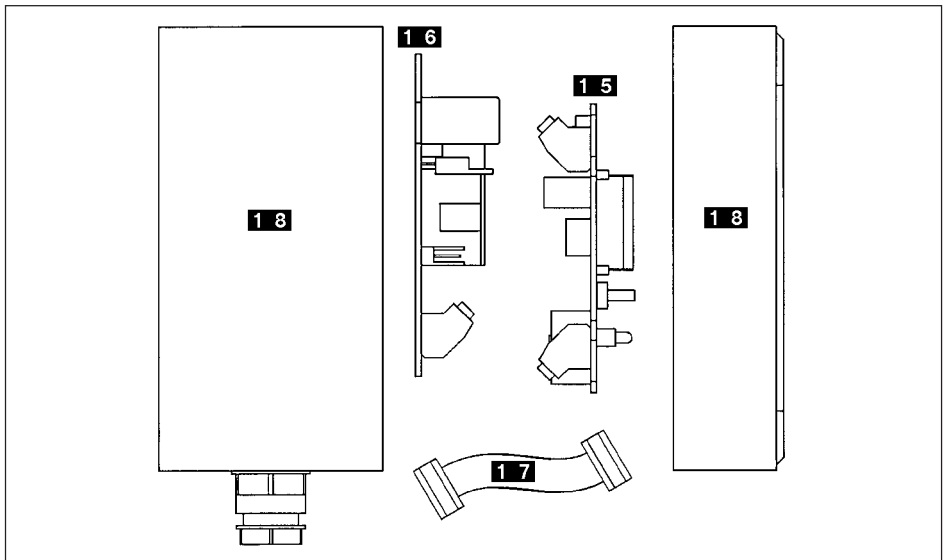

Fig. 5.2 Spare Parts Explosion Drawing Panel Version

## Wall-mounted Version

Position	Specification	Order N°
15	Electronic board batch controller type 8025	418098T
16	Power supply board 12...30 VDC	419639E
	Power supply board 230/115 VAC	419640K
17	Sensor connection cable between transmitter and power supply	420403Y
18	Complete enclosure	418389B



**Fig. 5.3 Spare Parts Explosion Drawing Wall-mounted Version**

Flow Chart (l/min, DN in mm and m/s)

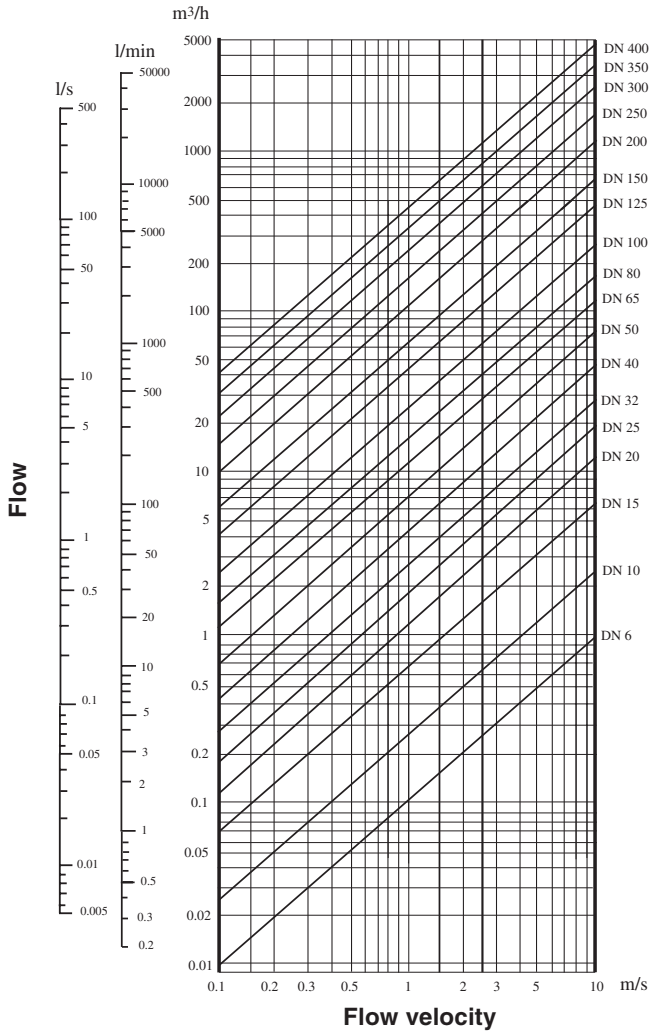

Selection Example:

**Specifications:**  
 Nominal flow:  $10m^3/h$   
 Determination with  
 ideal flow velocity:  $2...3 m/s$

With these specifications, the required orifice, as defined by the flow chart is DN 40.



Flow Chart (gpm, DN in inch and fps)

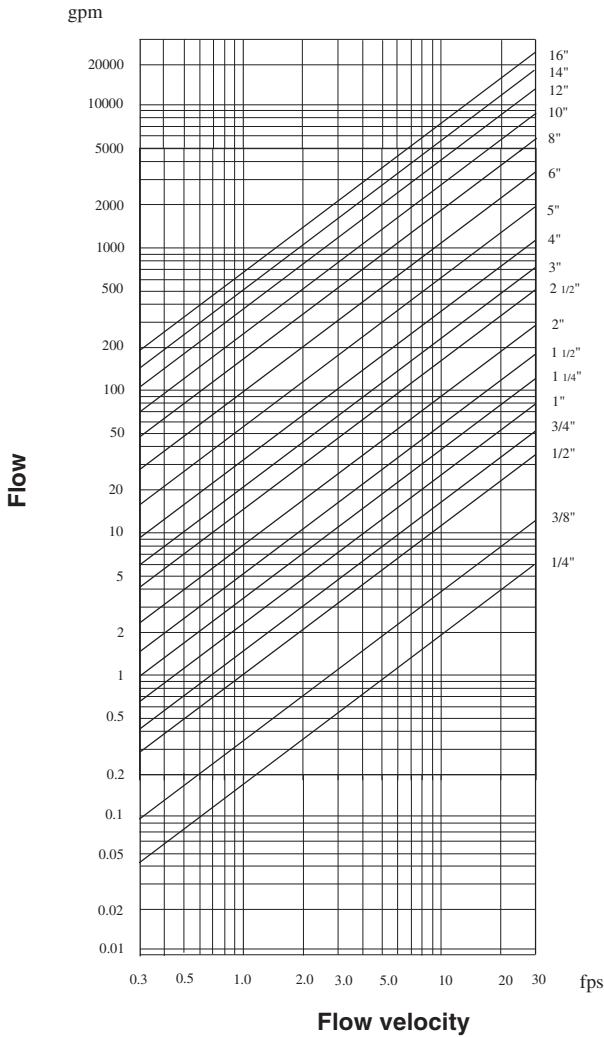

**Selection Example:**

**Specifications:**

Nominal flow: 50 gpm  
 Determination with  
 ideal flow velocity: 8 fps

With these specifications, the required orifice, as defined by the flow chart is 1 1/2".

# SERVICE

---

## Australia

Bürkert Fluid Control Systems  
Unit 1 No.2, Welder Road  
Seven Hills NSW 2147  
Tel +61 (0) 2 967 461 66  
Fax +61 (0) 2 967 461 67

## Austria

Bürkert Contromatic GmbH  
Central and Eastern Europe  
Diefenbachgasse 1-3  
A-1150 Wien  
Tel +43 (0) 1 894 13 33  
Fax +43 (0) 1 894 13 00

## Belgium

Bürkert Contromatic N.V./S.A.  
Middelmolenlaan 100  
B-2100 Deurne  
Tel +32 (0) 3 325 89 00,  
Fax +32 (0) 3 325 61 61

## Canada

Bürkert Contromatic Inc.  
760 Pacific Road, Unit 3  
Oakville, Ontario, L6L 6M5  
Tel +1 905 847 55 66,  
Fax +1 905 847 90 06

## China

Bürkert Contromatic  
(Suzhou) Co. Ltd.  
2/F, 71 Zhu Yuan Road  
215011 Suzhou  
Tel +86 512 808 19 16  
Fax +86 512 824 51 06

## Bürkert Contromatic

China/HK Ltd.  
Rm. 1313  
No. 103, Cao Bao Road  
200233 Shanghai P.R.C.  
Tel +86 21 6427 1946  
Fax +86 21 6427 1945

Bürkert Contromatic  
China/HK Ltd.  
Beijing Office  
Rm. 808, Jing Tai Building  
No. 24, Jianguomen  
Waidajie  
100022 Beijing P.R.C.  
Tel +86 10 65 15 65 08  
Fax +86 10 65 15 65 07

## Bürkert Contromatic China/HK Ltd.

Cheng Du Representative Office  
Rm. 502, Fuji Building  
No. 26 Shududadao  
Dongfeng Street  
Chengdu P.R.C.  
Tel +86 28 443 1895  
Fax +86 28 445 1341

Bürkert Contromatic  
China/HK Ltd.  
Guangzhou Representative Office  
Rm. 1305, Tower 2  
Dong-Jun Plaza  
Dongfeng, Road East  
Guangzhou P.R.C.  
Tel +86 28 443 1895  
Fax +86 28 445 1341

## Denmark

Bürkert-Contromatic A/S  
Hørkær 24  
DK-2730 Herlev  
Tel +45 44 50 75 00  
Fax +45 44 50 75 75

## Finland

Bürkert Oy  
Atomitie 5  
SF-00370 Helsinki  
Tel +358 (0) 9 549 706 00  
Fax +358 (0) 9 503 12 75

## France

Bürkert Contromatic  
B.P. 21  
Triembach au Val  
F-67220 Villé  
Tel +33 (0) 388 58 91 11  
Fax +33 (0) 388 57 09 61

## Germany / Deutschland

Bürkert Steuer- und Regeltechnik  
Christian-Bürkert-Straße 13-17  
D-74653 Ingelfingen  
Tel +49 7940 10-0  
Fax +49 7940 10 361

Niederlassung NRW  
Holzener Straße 70  
D-58708 Menden  
Tel +49 2373 96 81-0  
Fax +49 2373 96 81-52

Niederlassung Frankfurt  
Am Flugplatz 27  
D-63329 Egelsbach  
Tel +49 6103 94 14-0  
Fax +49 6103 94 14-66

Niederlassung München  
Paul-Gerhardt-Allee 24  
D-81245 München  
Tel +49 89 82 92 28-0  
Fax +49 89 82 92 28-50

Niederlassung Berlin  
Bruno-Taut-Straße 4  
D-12524 Berlin  
Tel +49 30 67 97 17-0  
Fax +49 30 67 97 17-66

Niederlassung Dresden  
Christian Bürkert Straße 2  
D-01900 Großbröschen  
Tel +49 35952 3 63 00  
Fax +49 35952 3 65 51

Niederlassung Hannover  
Rendsburger Straße 12  
D-30569 Hannover  
Tel +49 511 9 02 76-0  
Fax +49 511 9 02 76-66

Niederlassung Stuttgart  
Karl-Benz-Straße 19  
D-70794 Filderstadt (Bernh.)  
Tel +49 711 4 51 10-0  
Fax +49 711 4 51 10-66

## Great Britain

Bürkert Contromatic Ltd.  
Brimscombe Port Business Park  
Brimscombe, Stroud, Glos.  
GL5 2QF  
Tel. +44 (0) 1453 73 13 53  
Fax +44 (0) 1453 73 13 43

## Hong Kong

Bürkert Contromatic  
(China/HK) Ltd.  
Unit 708, Prosperity Centre  
77-81 Container Port Road  
Kwai Chung N.T.  
Hong Kong  
Tel +852 248 012 02  
Fax +852 241 819 45

## Italy

Bürkert Contromatic Italiana S.p.A.  
Centro Direzionale 'Colombiolo'  
Via Roma 74  
I-20060 Cassina De' Pecchi (MI)  
Tel +39 02 959 071  
Fax +39 02 959 07 251

## Japan

Bürkert Contromatic Ltd.  
3-39-8 Shoan  
Suginami-ku  
Tokyo 167-0054  
Tel +81 (0) 3 3247 3411  
Fax +81 (0) 3 3247 3472

## Korea

Bürkert Contromatic Korea Co. Ltd.  
4-10 Yangjae-Dong  
Seocho-Ku  
Seoul 137-130  
Tel. +82 (0) 2 346 255 92  
Fax +82 (0) 2 346 255 94

# SERVICE

---

## Malaysia

Bürkert Malaysia Sdn. Bhd.  
N° 22 Lorong Helang 2  
11700, Sungai Dua  
Penang  
Tel. +60 (0) 4 657 64 49  
Fax +60 (0) 4 657 21 06

## Netherlands

Bürkert Contromatic BV  
Computerweg 9  
NL-3606 AV Maarssen  
Tel. +31 (0) 346 58 10 10  
Fax +31 (0) 346 56 37 17

## New Zealand

Burkert Contromatic Ltd.  
Unit 5, 23 Hannigan drive  
Mt Wellington  
Auckland  
Tel +64 (0) 9 570 25 39  
Fax +64 (0) 9 570 25 73

## Norway

Bürkert Contromatic A/S  
Hvamstuppen 17  
Box 243  
N-2026 Skjetten  
Tel +47 63 84 44 10  
Fax +47 63 84 44 55

## Poland

Bürkert Contromatic Sp.z.o.o.  
1 Szpitalna Street  
PL-00-684  
Warszawa  
Tel +48 (0) 22 827 29 00  
Fax +48 (0) 22 627 47 20

## Singapore

Burkert Contromatic Singapore Pte.Ltd.  
No.11 Playfair Road  
Singapore 367986  
Tel +65 383 26 12  
Fax +65 383 26 11

## Spain

Bürkert Contromatic Española S.A.  
San Gabriel 40-44  
E-08950 Esplugues de Llobregat  
Tel +34 93 371 08 58  
Fax +34 93 371 77 44

## South Africa

Burkert Contromatic Pty.Ltd.  
P.O.Box 26260, East Rand 1462  
Republic of South Africa  
Tel +27 (0) 11 397 2900  
Fax +27 (0) 11 397 4428

## Sweden

Bürkert Contromatic AB  
Skeppsbron 13 B  
S-21120 Malmö  
Tel +46 (0) 40 664 51 00  
Fax +46 (0) 40 664 51 01

## Bürkert Contromatic AB

Havsörnstorget 21  
Box 1002  
S-12349 Farsta  
Tel +46 (0) 40 664 51 00  
Fax +46 (0) 8 724 60 22

## Switzerland

Bürkert-Contromatic AG Schweiz  
Bösch 65  
CH-6331 Hünenberg / ZG  
Tel +41 (0) 41 785 66 66  
Fax +41 (0) 41 785 66 33

## Taiwan

Bürkert Contromatic Taiwan Ltd.  
3F No. 475 Kuang-Fu South Road  
R.O.C - Taipei City  
Tel +886 (0) 2 275 831 99  
Fax +886 (0) 2 275 824 99

## Turkey

Bürkert Contromatik  
Akiskan Kontrol Sistemleri Ticaret  
A.S  
1203/8 Sok. No. 2-E  
Yenisehir  
Izmir  
Tel +90 (0) 232 459 53 95  
Fax +90 (0) 232 459 76 94

## Tzechia

Bürkert Contromatic Spol.s.r.o  
Prosenice c. 180  
CZ - 751 21 Prosenice  
Tel +42 0641 226 180  
Fax +42 0641 226 181

## USA/West/Main office

Burkert Contromatic Corp.  
2602 McGaw Avenue  
Irvine, CA 92614, USA  
Tel. +1 949 223 31 00  
Fax +1 949 223 31 98

## USA/South

Burkert Contromatic Corp.  
6724 Alexander Road  
Charlotte, North Carolina, 28270  
Tel. +1 704 367 11 73  
Fax +1 704 367 11 74

## USA/North-East

Burkert Contromatic Corp.  
7173 Thermal Road  
Charlotte, North Carolina, 28211  
Tel. +1 704 366 21 41  
Fax +1 704 366 24 28

## USA/West

Burkert Contromatic Corp.  
4449 East Bradford  
Orange, CA 92867  
Tel. +1 714 637 26 39  
Fax +1 714 637 21 62

## USA/Mid-West

Burkert Contromatic Corp.  
6245 Kincora Court  
Cincinnati, OH 45233  
Tel. +1 513 941 34 78  
Fax +1 513 941 29 05

