

8223

INDUCTIVE CONDUCTIVITY SENSOR



Instruction Manual

bürkert
Fluid Control Systems

Table of Contents

1. INTRODUCTION	3
1.1 Symbols used	3
1.2 General safety instructions	3
2. QUICK START	4
2.1 Quick installation guide	4
3. CONFIGURATION	6
3.1 General comments	6
3.2 Measuring range	6
3.2.1 Measuring range of the conductivity	6
3.2.2 Measuring range of the temperature	8
3.3 Filtering level	9
3.4 Temperature compensation	10
3.4.1 Specific compensation	10
3.4.2 Linear compensation	11
3.5 Transmission of the temperature	12
3.6 Calibrating the “zero conductivity” point	12
4. INSTALLATION	13
4.1 Mounting instructions	13
4.1.1 Temperature-pressure diagram	13
4.1.2 Installation recommendations	13
4.2 Mounting	14
4.3 Electrical connection instructions	15
4.3.1 Mounting and connection of the DIN 43650 connector	15
4.3.2 Connecting the 8223 to an external device (PLC,...)	16
4.3.3 Precautions during installation and commissioning	16
4.4 Examples of EASY LINKS which can be made with a 8223 sensor	17
5. MAINTENANCE	18
5.1 Maintenance	18
5.2 If a problem occurs.. ..	18
6. TECHNICAL SPECIFICATIONS	19
6.1 Process characteristics	19
6.2 Electrical characteristics	19
6.3 User characteristics	20
6.4 Safety	20
6.5 Environment	20
6.6 Conformity with standards	20
7. INFORMATION	21
7.1 Standard delivery	21
7.2 Order codes	21
7.3 Measurement principle	21
7.4 Dimensions (mm)	22

1.1 SYMBOLS USED



Indicates information which must be followed. Failure to follow the information could endanger the user and affect the function of the device.



Indicates that the page contains general information.



Indicates a quickstart guide for quickly commissioning the sensor.



Indicates that the page contains information about installation.



Indicates that the page contains information about configuration, programming and operation.



Indicates important information, tips and recommendations.



Indicates a worked example.

Indicates an action which has to be continued or reference to a relevant section.



Indicates information about repairs, service, maintenance and spare parts.

1.2 GENERAL SAFETY INSTRUCTIONS



Before installing or using this product, please read this manual and any other relevant documentation to ensure you fully benefit from all the advantages the product can offer.

- Please verify that the product is complete and free from any damage.
- It is the customer's responsibility to select an appropriate sensor for the application, ensure the unit is installed correctly, and maintain all components.
- This product should only be installed or repaired by specialist staff using the correct tools.
- Please observe the relevant safety regulations throughout the operation, maintenance and repair of the product.
- Always ensure that the power supply is switched off and the pipes / tank do not contain any pressure before working on the device / system.
- If these instructions are ignored or the sensor is not used according to the specifications, no liability will be accepted and the guarantee on the device and accessories will become invalid.
- This electronic device is sensitive to electrostatic discharge. To avoid any damage by immediate electrostatic discharge, pay attention to the requirements of EN 100 015-1.
- Always protect the device from electromagnetic perturbations, and when installed outside, protect it from the rain and ultraviolet radiations.

2.1 QUICK INSTALLATION GUIDE

ENGLISH

2.1

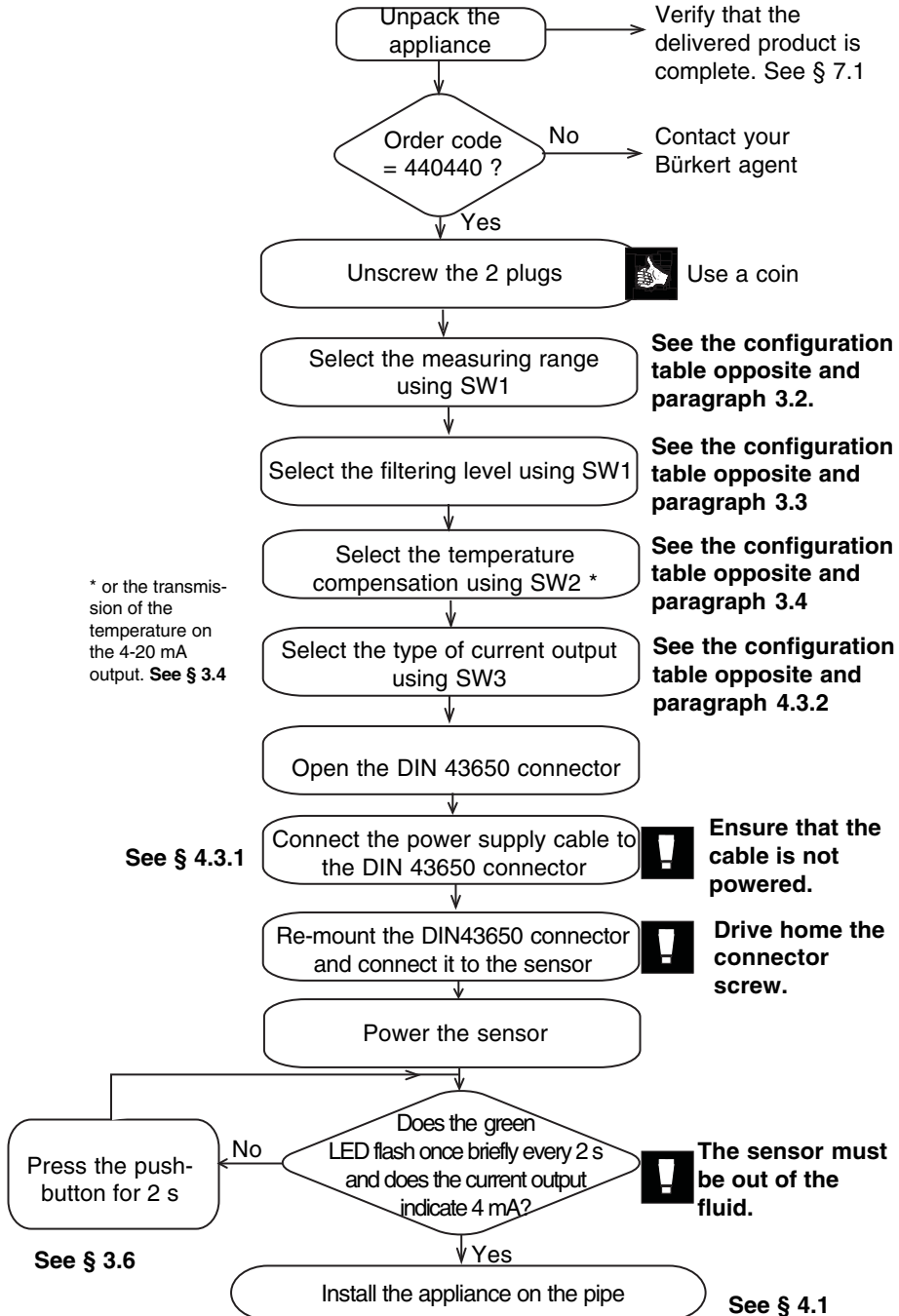

* or the transmission of the temperature on the 4-20 mA output. See § 3.4

Measuring range	Position of the switches of SW1	
	1	2
0 to 1 mS/cm	OFF	OFF
0 to 10 mS/cm (default value)	OFF	ON
0 to 100 mS/cm	ON	OFF
0 to 1 S/cm	ON	ON

Filtering level	Position of the switches of SW1	
	3	4
0 (no filtering) Default value	OFF	OFF
1 (min. filtering)	OFF	ON
2 (medium filtering)	ON	OFF
3 (max. filtering)	ON	ON

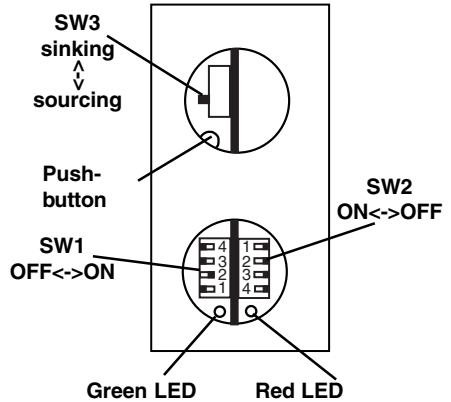

Temperature compensation		Position of the switches of SW2			
		1	2	3	4
No compensation (Default value)		OFF	OFF	OFF	OFF
Linear compensation	0,1%	ON	OFF	OFF	OFF
	0,25%	OFF	ON	OFF	OFF
	0,5%	ON	ON	OFF	OFF
	0,7%	OFF	OFF	ON	OFF
	1%	ON	OFF	ON	OFF
	1,5%	OFF	ON	ON	OFF
	2%	ON	ON	ON	OFF
	3%	OFF	OFF	OFF	ON
	5%	ON	OFF	OFF	ON
Specific compensation	NaOH	OFF	ON	OFF	ON
	HNO ₃	ON	ON	OFF	ON
	H ₂ SO ₄	OFF	OFF	ON	ON
	NaCl	ON	OFF	ON	ON
Not used		OFF	ON	ON	ON

Transmission of the temperature to the 4-20 mA output	Position of the switches of SW2			
	1	2	3	4
	ON	ON	ON	ON

Type of current output	Position of SW3 switch
Sinking	Up
Sourcing (Default value)	Down

Green LED	Red LED	Status of the sensor when operating faultless
ON	ON	Calibration of the "zero conductivity" in progress
Flashes once briefly	OFF	Measurement of a nil conductivity (< 1% of the measuring full scale)
Flashes at a frequency between 0,5 and 16 Hz		Measurement of a conductivity which is proportional to this frequency



See also § 5.2 for any other LED flashing.



3.1 GENERAL COMMENTS

Configuration is done by means of accessible switches after having unscrewed the plugs counterclockwise and removed them.

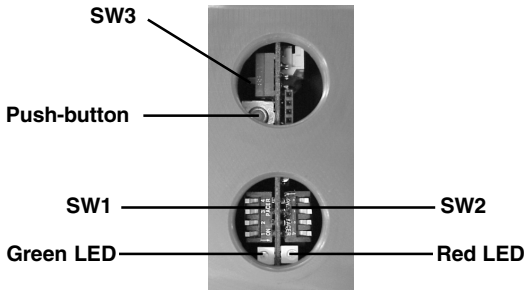

- SW1 allows the selection of:
 - the measuring range (switches 1 and 2)
 - the filtering level of the conductivity (switches 3 and 4)
- SW2 allows the selection of the temperature compensation or the transmission of the temperature on the 4-20 mA output.
- SW3 allows the selection of the current output mode, sinking or sourcing.
- The push-button allows the calibration of the sensor «zero conductivity» point.

3.2 MEASURING RANGE

The 4-20 mA output delivers a current which is proportional to the compensated or not compensated conductivity or to the measured temperature. For the conductivity, the user may choose the measuring range.



When the conductivity exceeds the full scale by 10%, the current output delivers a 22 mA current. As soon as the conductivity is again equal or inferior to the full scale value, the current output delivers a current between 4 and 20 mA.

3.2.1 Measuring range of the conductivity

SW1 makes it possible to select the conductivity measuring range:

Measuring range	Position of the switches of SW1	
	1	2
0 to 1 mS/cm	OFF	OFF
0 to 10 mS/cm (default value)	OFF	ON
0 to 100 mS/cm	ON	OFF
0 to 1 S/cm	ON	ON

- a 4 mA current indicates a conductivity which is equal to 0 mSiemens/cm (less than 1% of the selected full scale)



- a 20 mA current indicates a conductivity which is equal to either:
 - 1 mSiemens/cm (mS/cm)
 - 10 mS/cm
 - 100 mS/cm
 - 1 S/cm

The conductivity depending on the material the used fitting is made of and its diameter, the full scale value must be re-calculated using the following formula:

$$FS = FS_s \times C_F$$

where FS = Full Scale value to be programmed on the PLC

FS_s = selected Full Scale

C_F = Correction factor of the fitting used: see the following tables

Correction factors					
Type of fitting	Butt-weld ends Internal threads External threads		Sockets Solvent cement spigots Fusion spigots		
	Material	Brass	Stainless steel	PVDF	PP
DN32	0,991	0,989	1,113	1,098	1,093
DN40	0,989	0,989	1,049	1,045	1,045
DN50	0,985	0,983	1,022	1,021	1,022

Correction factors					
Type of fitting	Butt-weld ends or fusion spigots				Saddles
	Material	Brass	Stainless steel	PVDF	PP
DN65	-	0,993	1,020	1,019	1,025
DN80	-	0,995	1,020	1,019	1,022
DN100	-	0,998	1,019	1,017	1,010



- If a fitting with DN15, 20 or 25 is used, use the correction factor of the DN32
- If a fitting with a DN > 100 or a vessel is used, apply a correction factor = 1.

Example:

The 8223 sensor is installed in a PVDF S020 fitting with DN32.

The selected full scale is FS_s = 10 mS/cm.

The correction factor for this fitting is C_F = 1,113.

Thus: FS = FS_s x C_F = 10 x 1,113 = 11,13 mS/cm



3.3 FILTERING LEVEL

Filtering allows the attenuation of fluctuations in the conductivity. The 8223 sensor has four filtering levels, from 0 to 3:

- Level 0 corresponds to a nil filtering: the sensor indicates any conductivity variation
- Level 3 corresponds to the maximum filtering: the sensor smoothes the conductivity variations at the most
- Levels 1 and 2 correspond to intermediate filterings.

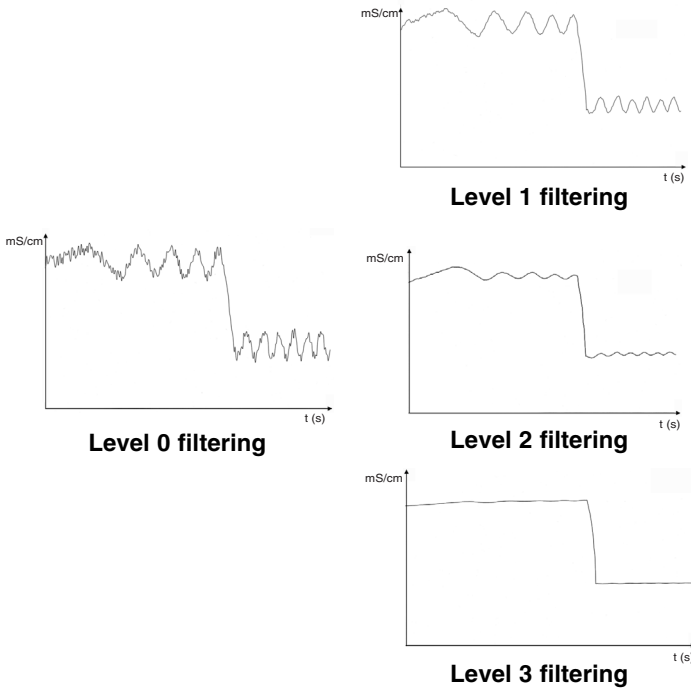

SW1 allows the selection of the filtering level:

Filtering level	Position of the switches of SW1	
	3	4
0 (no filtering) Default value	OFF	OFF
1 (min. filtering)	OFF	ON
2 (medium filtering)	ON	OFF
3 (max. filtering)	ON	ON

ENGLISH
3.3



3.4 TEMPERATURE COMPENSATION

The conductivity varies with the temperature; To compensate the variations, the 8223 sensor measures the real conductivity and temperature of the fluid then re-calculates the conductivity corresponding to a temperature of 25 °C.

SW2 makes it possible to choose the calculation mode of the temperature compensation.

Three calculation modes are possible, either:

- a specific compensation: 4 compensation curves are memorized by the sensor for the following solutions: **NaOH (sodium hydroxyde)**, **HNO₃ (nitric acid)**, **H₂SO₄ (sulphuric acid)**, and **NaCl (sodium chloride)**.
- a linear compensation: 9 compensation factors, from 0.1 to 5% can be chosen.
- no compensation.

3.4.1 Specific compensation

The specific compensation curves for **NaOH (sodium hydroxyde)**, **HNO₃ (nitric acid)** and **NaCl (sodium chloride)** are valid for temperatures ranging from 10 to 70 °C.

The specific compensation curve for **H₂SO₄ (sulphuric acid)** is valid for temperatures ranging from 5 to 55 °C.

The compensation has been determined at the following concentrations:

NaOH : 1%
HNO₃ : 1%
NaCl : 0,2%
H₂SO₄ : 20%



- The NaCl specific curve is valid for concentrations ranging from 60 mg/l (conductivity \cong 100 μ S/cm) to 270 g/l (conductivity \cong 220 mS/cm).
- The NaCl compensation curve can be used for some dilute solutions.
- If the fluid of your process does not correspond to any specific solution, use one of the linear compensations.



3.4.2 Linear compensation

If no specific compensation curve corresponds to your process, use one of the 9 linear compensation factors by using SW2.

If you do not know the compensation factor (average α) of your process, you can determine it by doing the following:

- 1) Measure the conductivity of the fluid at 25 °C (χ_{25})
- 2) Measure the conductivity of the fluid at a temperature T (χ_T)
- 3) Apply the following formula to determine the α factor:

$$\alpha = \frac{\chi_T - \chi_{25}}{T - 25} \times \frac{1}{\chi_{25}}$$

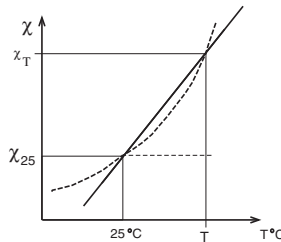

- 4) Use the compensation factor nearest to the calculated one:

Temperature compensation		Position of the switches of SW2			
		1	2	3	4
No compensation (Default value)		OFF	OFF	OFF	OFF
Linear compensation	0,1%	ON	OFF	OFF	OFF
	0,25%	OFF	ON	OFF	OFF
	0,5%	ON	ON	OFF	OFF
	0,7%	OFF	OFF	ON	OFF
	1%	ON	OFF	ON	OFF
	1,5%	OFF	ON	ON	OFF
	2%	ON	ON	ON	OFF
	3%	OFF	OFF	OFF	ON
Specific compensation	5%	ON	OFF	OFF	ON
	NaOH	OFF	ON	OFF	ON
	HNO ₃	ON	ON	OFF	ON
	H ₂ SO ₄	OFF	OFF	ON	ON
	NaCl	ON	OFF	ON	ON
Not used		OFF	ON	ON	ON



3.5 TRANSMISSION OF THE TEMPERATURE

If, instead of the conductivity, the 8223 sensor is meant to transmit the temperature (between -10 °C and 80 °C) to the 4-20 mA output, configure SW2 as follows:

Transmission of the temperature to the 4-20 mA output	Position of the switches of SW2			
	1	2	3	4
	ON	ON	ON	ON



Thus the conductivity measuring range chosen with SW1 is not taken into account.

3.6 CALIBRATING THE “ZERO CONDUCTIVITY” POINT

The “zero conductivity” point of the sensor can drift in time. To check whether the sensor is correctly calibrated or not, measure the conductivity of the air (conductivity = 0).

- Dismantle the sensor from the pipe.



Ensure the finger orifice the fluid passes through is clean and dry.

- If the conductivity of the air > 0 (the current output indicates a value > 4 mA and the green LED flashes at a frequency between 0.5 and 16 Hz), press the push button for at least 2 s: both LEDs light up and the sensor starts calibrating its “zero conductivity” point.

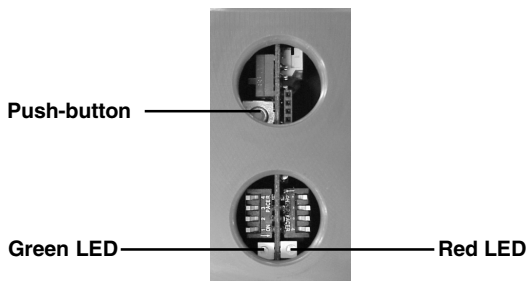

The operation can last a few minutes.

The calibration is finished when the two LEDs are not steadily lit any more. Then:

- If the red LED switches off and the green LED flashes rapidly every 2 s, the sensor is correctly calibrated.
- If the green LED lights up and the red LED flashes 3 or 4 times every 2 s, the calibration has failed: press the push-button briefly to go back to normal operating using the parameters of the previous calibration. If the calibration fails several times in a row, contact your Bürkert agent.



4.1 MOUNTING INSTRUCTIONS

4.1.1 Temperature-pressure diagram

The sensor and the fitting in which it is installed have limited operating temperatures and pressures. The diagram hereunder shows the operating range of the 8223-fitting assembly, for each fitting material:

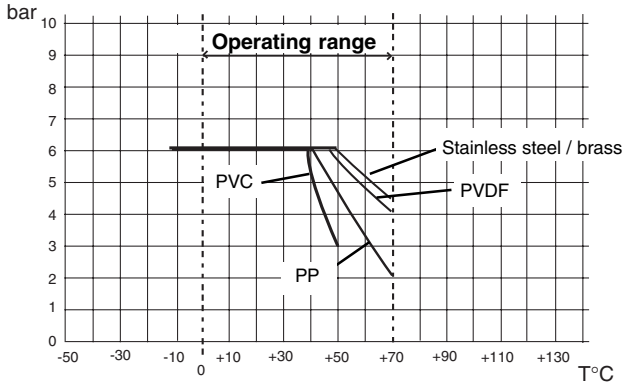

4.1.2 Installation recommendations

Choose a mounting position which avoids the building of air bubbles or cavities within the finger orifice.

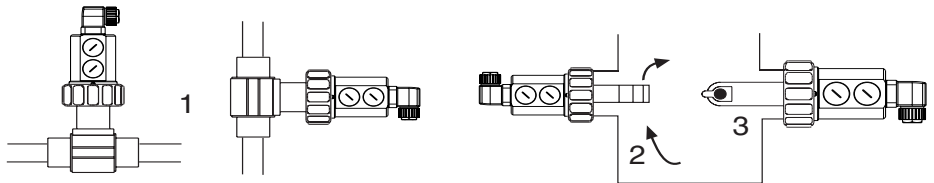

Position 1: horizontal or vertical mounting onto a pipe.

Position 2: mounting on a vessel without stirring

position 3: mounting on a vessel with stirring



- When dismantling the sensor from the pipe, take all the precautions related to this process.
- Ensure the fluid passage orifice is in the direction of the flow.



4.2 MOUNTING

The 8223 conductivity sensor is installed on a pipe as follows:

- Insert the nut [4] on the fitting [6] and clip the ring [3] in the groove [5].
- Insert the sensor [1] into the fitting [6] by ensuring the gasket [2] is in its right place.
- Screw on the nut and tighten by hand only.

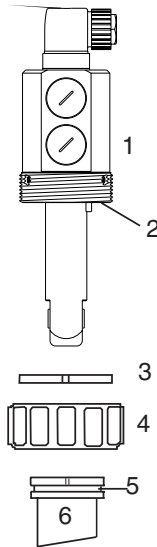

- Ensure the gasket material (FPM in standard) is chemically compatible with your process.
- Two EPDM gaskets are additionally supplied with the sensor.
- Make sure the gasket is not damaged when replacing it.



4.3 ELECTRICAL CONNECTION INSTRUCTIONS

Always ensure that the appliance is not powered before working on it. All the connections must be disconnected.

- Use a shielded cable with a limit operating temperature $> +80^{\circ}\text{C}$.
- Under normal conditions of use, a single cable of 0.75 mm^2 section is sufficient for signal transmission.
- Do not install the line close to high voltage or high frequency cables.
- If adjacent laying is unavoidable, keep a minimum distance of 30 cm or use shielded cable.
- If shielded cable is used, correctly connect the shielding to earth.



- In case of doubt, use shielded cable.
- Use a quality power supply (filtered and regulated).



- Do not open or cable the sensor when powered.
- It is essential that a 100 mA fuse be used for the power supply.

4.3.1 Mounting and connection of the DIN 43650 connector

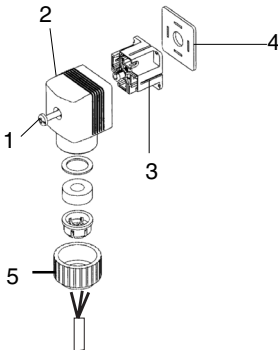

- Extract part [3] from part [2] using a flat screwdriver.
- Make the connections (see above)
- Replace part [3].
- Tighten the cable gland [5].
- Place the seal [4] between the connector and the 8223 fixed connector, making sure the gasket material is chemically compatible with your process.
- Connect the connector to the 8223 sensor.
- Tighten the screw [1].

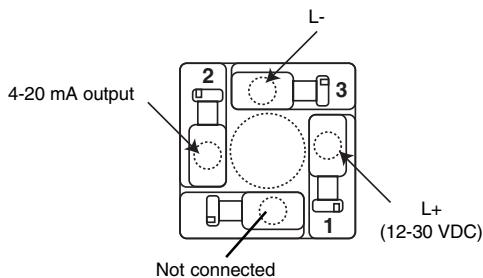

Always check the connection of the connectors to ensure correct operation of the appliance.



INSTALLATION

4.3.2 Connecting the 8223 to an external device (PLC,...)

The 8223 sensor can be connected to a PLC or any other device which is able to use the 4-20 mA signal transmitted by the sensor.

The connection can be carried out either in sourcing or in sinking mode, as shown by the figures below:

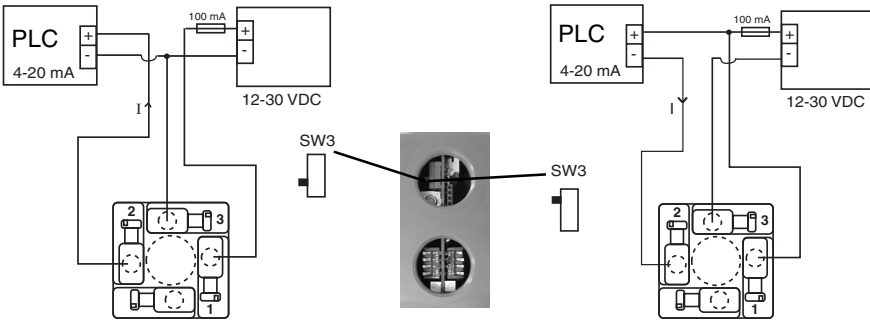

Connection in sourcing mode

Connection in sinking mode

SW3 must be configured correctly when the sensor is not powered, depending on the connection mode chosen.

Type of current output	Position of SW3 switch
Sinking	Up
Sourcing (Default value)	Down

4.3.3 Precautions during installation and commissioning

- When the appliance is powered and the cover is open, the protection against electrical shocks is no longer effective.
- Always verify the chemical compatibility of the materials which are in contact with the fluid to be measured.
- When cleaning the appliance use products which are chemically compatible with the materials in the appliance.
- Do not insert any object (screwdriver for instance) within the finger orifice. When the orifice is dirty, use compressed air to clean it.



4.4 EXAMPLES OF EASY LINKS WHICH CAN BE MADE WITH A 8223 SENSOR

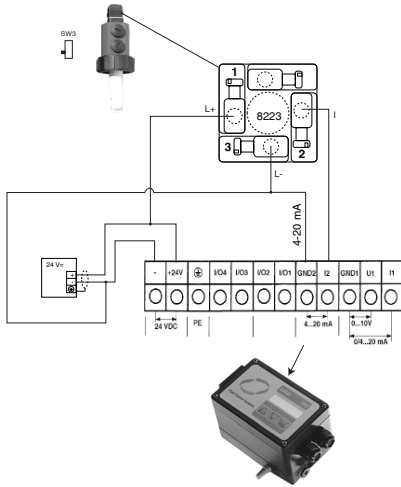

Between the 8223 sensor and the 1067 positioner.

Between the 8223 sensor and a solenoid valve with 8624-2 PI controller.

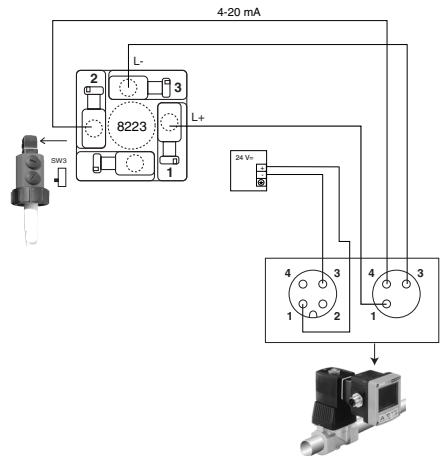

Between the 8223 sensor and the 8630 Top Control mounted on a 2031 diaphragm valve.

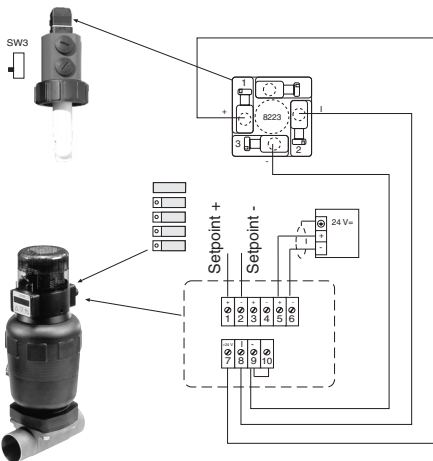



5.1 MAINTENANCE

The 8223 sensor may be cleaned with water or a product which is compatible with the materials therein.

Your Bürkert supplier is available to provide you with any additional information you require.

5.2 IF A PROBLEM OCCURS...

An error is indicated by lighting up of the green LED, special flashing of the red LED and the transmission of a 22-mA current to the current output.

The following table lists possible faults that can occur and their solutions:

Problem	Green LED status	Red LED status	Current output status	Possible cause	Do the following	See also
The sensor does not work	OFF	OFF	0 mA	The sensor is not connected	Connect the sensor	4.3
				The fuse of the installation is in a bad condition	Change the fuse	--
				The switch of the installation is set to OFF	Set the switch to ON	--
				The power supply has been wrong connected to the + and - terminals	Check the wiring	4.3
				The power supply is not stable or < 12 VDC	Change the power supply	--
The sensor measures a wrong conductivity	Flashes briefly	OFF	4 mA	The "zero conductivity" point has been calibrated within the fluid or the "zero conductivity" point has drifted	Carry out a calibration in air	3.5
	Flashes	OFF	-	The finger is dirty	Clean the sensor finger	5.1
				Air bubbles appear within the finger orifice	Follow the mounting instructions	4.1.2
				The temperature compensation is not correct	Select an appropriate compensation	3.4
			The conductivity fluctuations are very important	Select a higher filtering level (SW1)	3.3	
The sensor transmits a nil conductivity	Flashes briefly	OFF	4 mA	The chosen measuring range is not appropriate	Select the lower measuring range (SW1)	3.2
The sensor transmits no current at all	Flashes	Flashes	0 mA	SW3 is not set correctly (sourcing or sinking)	Modify SW3	4.3.2
				The current output is not connected properly	Re-connect the current output	4.3
The sensor is stopped - an error is indicated	ON	Flashes once briefly every 2 s	22 mA	The conductivity > full scale + 10%	Select the next measuring range (SW1)	3.2.1
	ON	Flashes twice briefly every 2 s	22 mA	The fluid temperature < -10 °C or > 80 °C	Bring the fluid temperature back to a value within the sensor measuring range	3.2.2
	ON	Flashes 3 or 4 times briefly every 2 s	22 mA	The "zero conductivity" point calibration failed	Press the push-button briefly. If the error persists, send the device back to Bürkert.	3.6
	Flash simultaneously		22 mA	The sensor is out of service	Send the device back to Bürkert	-

6.1 PROCESS CHARACTERISTICS

Conductivity measurement

- | | |
|--|---------------------------------------|
| - Type of measurement | Inductive conductivity measurement |
| - Measuring range | 0 μ S/cm to 1 S/cm |
| - Precision | +/-2% of the selected measuring range |
| - Temperature deviation | 0.2% / °C max. |
| - Answering time at a strong conductivity change | < 1 s |
| - Sampling frequency | measurement every 250 ms |

Temperature measurement

- | | |
|--|---------------------|
| - Type of measurement | digital measurement |
| - Measuring range | -10 °C to 80 °C |
| - Precision | +/- 0.5 °C |
| - Answering time at a strong conductivity change | 100 s |
| - Sampling frequency | 250 ms |

General data

- | | |
|---------------------------------------|------------------------------------|
| - Pipe interface | standard Bürkert fitting |
| - Pressure class | PN6 |
| - Fluid temperature range | 0 to 70 °C |
| - Materials in contact with the fluid | Finger: PVDF
Seals: FPM or EPDM |

6.2 ELECTRICAL CHARACTERISTICS

Pulse rate output

- | | |
|------------------------|---|
| - Output type | current output from 4 to 20 mA (error signal at 22 mA) |
| - Electrical wiring | Wiring in sourcing or sinking mode, can be selected by bipolar reverser |
| - Max. load resistance | 1000 Ohms with a power supply of 30 V
690 Ohms with a power supply of 24 V
300 Ohms with a power supply of 15 V
150 Ohms with a power supply of 12 V |
| - Adjustment | 4 conductivity ranges and 1 temperature range, can be selected by switch |

Electrical connection

- | | |
|-------------------------------|---|
| - Power supply voltage | 12 to 30 VDC, regulated |
| - Maximum current consumption | 50 mA max. + 22 mA for the current output |
| - Connector type | DIN43650 |

6.3 USER CHARACTERISTICS

- Measurement indication
By a green-coloured led flashing from 0.5 to 16 Hz depending on the conductivity; It flashes briefly every 2 seconds when the fluid conductivity is lower than 1% of the selected full scale
- Error message
By two green and red-coloured leds (see 5.2)
- Programming the scale of measurement
4 measurement ranges selectable by means of 2 switches
- Filtering the conductivity
4 filtering levels selectable by means of 2 switches
- Temperature compensation
14 compensation types (9 proportional compensation levels and 4 solution specific levels), selectable by means of 4 switches (reference temperature = 25 °C)
- Calibration of «zero conductivity» point
By means of a push-button

6.4 SAFETY

Electrical input and output protected against polarity reversal.

6.5 ENVIRONMENT

- Operating and storage temperatures
0 to 60 °C
- Operating and storage humidity rating
< 80%
- Housing materials
PEHD
- Protection rating
IP65, connector plugged in and tightened

6.6 CONFORMITY WITH STANDARDS

- Emission
EN 50081.1
- Protection
EN 50082.2
- Safety
EN 61010-1

7.1 STANDARD DELIVERY

The standard delivery comprises:

- an 8223 sensor
- a set of 2 EPDM gaskets
- a DIN43650 connector

7.2 ORDER CODES

Complete sensor: 440440

Spare parts:

Description	Order code
Female fixed connector Pg9 + screw + NBR gasket	438811
Female fixed connector Pg9 + screw + silicone gasket	156927
Female fixed connector G1/2" + screw + gasket	438682
Silicone gasket for Pg9 or G1/2" female fixed connector	440244
Set of M20x1.5 plugs with gaskets	444705
Retaining ring	619205
Tightening nut	619204
FPM gasket set	425554
EPDM gasket set	425555

ENGLISH

7.3

7.3 MEASUREMENT PRINCIPLE

Conductivity is the ability of a liquid / solution to conduct an electrical current. To measure the conductivity of a solution the 8223 conductivity sensor uses the following principle:

- A voltage is connected to the primary magnetic coil.
- The induced magnetic field generates a current in the secondary magnetic coil.
- The intensity of the current is a direct function of the conductivity of the solution between the 2 magnetic coils.

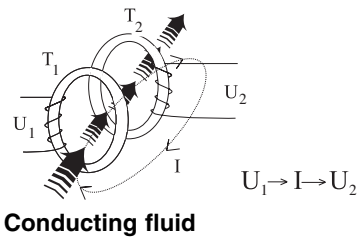

7.4 DIMENSIONS (MM)