

■ Contents

Introduction to HVAC	2
Available literature	2
Choice of frequency converter	2
Unpacking and ordering a VLT frequency converter	6
Type code ordering number string	6
Ordering form	10
PC software and serial communication	11
PC Software tools	12
Fieldbus options	12
Profibus	12
LON - Local Operating Network	12
DeviceNet	13
Modbus RTU	13
Control unit (LCP)	15
Installation	22
Mains supply (L1, L2, L3)	22
Max. imbalance of supply voltage	22
Technical data, mains supply 3 x 200-240 V	27
Technical data, mains supply 3 x 380-460 V	29
Technical data, mains supply 3 x 525-600 V	34
Fuses	38
Mechanical dimensions	40
Index	44

■ Introduction to HVAC

■ Available literature

Below is a list of the literature available for VLT 6000 HVAC. It must be noted that there may be deviations from one country to the next.

Please also refer to our web site <http://drives.danfoss.com> for information about new literature.

Supplied with the unit:

Operating instructions	MG.61.AX.YY
Quick Setup	MG.60.CX.YY
High Power Installation Guide	MI.90.JX.YY

Communication with VLT 6000 HVAC:

Software Dialog	MG.50.EX.YY
Profibus Manual	MG.10.LX.YY
Metasys N2 Manual	MG.60.FX.YY
LonWorks Manual	MG.60.EX.YY
Landis/Staefa Apogee FLN Manual	MG.60.GX.YY
Modbus RTU Manual	MG.10.SX.YY
DeviceNet Manual	MG.50.HX.YY

Instructions for VLT 6000 HVAC:

LCP Remote Kit IP20	MI.56.AX.51
LCP Remote Kit IP54	MI.56.GX.52
LC-filter	MI.56.DX.51
IP20 terminal cover	MI.56.CX.51
RCD instructions	MI.66.AX.YY
Relay card instructions	MI.66.BX.YY

Various literature for VLT 6000 HVAC:

Design Guide	MG.61.BX.YY
Data sheet	MD.60.AX.YY
VLT 6000 HVAC Cascade Controller	MG.60.IX.YY

X = version number

YY = language version

■ Choice of frequency converter

The frequency converter should be chosen on the basis of the given motor current at maximum load on the system. The rated output current $I_{VLT,N}$ must be equal to or higher than the required motor current.

VLT 6000 HVAC is available for three mains voltage ranges: 200-240 V, 380-460 V, and 525-600 V.

Choose mains voltage for 50/60 Hz:

- 200-240 V three-phase AC voltage
- 380-460 V three-phase AC voltage
- 525-600 V three-phase AC voltage

Mains voltage 200 - 240 V

VLT type	Typical shaft output		Max continuous output current $I_{VLT,N}$ [A]	Max continuous output power at 240 V $S_{VLT,N}$ [kVA]
	$P_{VLT,N}$ [kW]	[HP]		
6002	1.1	1.5	6.6	2.7
6003	1.5	2.0	7.5	3.1
6004	2.2	3.0	10.6	4.4
6005	3.0	4.0	12.5	5.2
6006	4.0	5.0	16.7	6.9
6008	5.5	7.5	24.2	10.1
6011	7.5	10	30.8	12.8
6016	11	15	46.2	19.1
6022	15	20	59.4	24.7
6027	18.5	25	74.8	31.1
6032	22	30	88.0	36.6
6042	30	40	115/104*	43.2
6052	37	50	143/130*	54.0
6062	45	60	170/154*	64.0

*The first figure is for a motor voltage of 200-230 V.
The next figure is for a motor voltage of 231-240 V.

Mains voltage 380 - 415 V

VLT type	Typical shaft output		Max continuous output current $I_{VLT,N}$ [A]	Max continuous output power at 400 V $S_{VLT,N}$ [kVA]
	$P_{VLT,N}$ [kW]			
6002	1.1		3.0	2.2
6003	1.5		4.1	2.9
6004	2.2		5.6	4.0
6005	3.0		7.2	5.2
6006	4.0		10.0	7.2
6008	5.5		13.0	9.3
6011	7.5		16.0	11.5
6016	11		24.0	17.3
6022	15		32.0	23.0
6027	18.5		37.5	27.0
6032	22		44.0	31.6
6042	30		61.0	43.8
6052	37		73.0	52.5
6062	45		90.0	64.7
6072	55		106	73.4
6102	75		147	102
6122	90		177	123
6152	110		212	147
6172	132		260	180
6222	160		315	218
6272	200		395	274
6352	250		480	333
6402	315		600	416
6502	355		658	456
6552	400		745	516
6602	450		800	554

VLT® 6000 HVAC Series

Mains voltage 440-460 V

VLT type	Typical shaft output	Max continuous output current	Max continuous output power
	P _{VLT.N} [HP]	I _{VLT.N} [A]	at 460 V S _{VLT.N} [kVA]
6002	1.5	3.0	2.4
6003	2.0	3.4	2.7
6004	3.0	4.8	3.8
6005	-	6.3	5.0
6006	5.0	8.2	6.5
6008	7.5	11.0	8.8
6011	10	14.0	11.2
6016	15	21.0	16.7
6022	20	27.0	21.5
6027	25	34.0	27.1
6032	30	40.0	31.9
6042	40	52.0	41.4
6052	50	65.0	51.8
6062	60	77.0	61.3
6072	75	106	84.5
6102	100	130	104
6122	125	160	127
6152	150	190	151
6172	200	240	191
6222	250	302	241
6272	300	361	288
6352	350	443	353
6402	450	540	430
6502	500	590	470
6552	600	678	540
6602	600	730	582

VLT® 6000 HVAC Series

Mains voltage 525 V

VLT type	Typical shaft output	Max. constant output current, 500 V	Max. constant output power at 500 V
	$P_{VLT.N}$ [kW]	$I_{VLT.N}$ [A]	$S_{VLT.N}$ [kVA]
6002	1.1	2.6	2.3
6003	1.5	2.9	2.5
6004	2.2	4.1	3.6
6005	3.0	5.2	4.5
6006	4.0	6.4	5.5
6008	5.5	9.5	8.2
6011	7.5	11.5	10.0
6016	11	18	15.6
6022	15	23	20
6027	18.5	28	24
6032	22	34	29
6042	30	43	37
6052	37	54	47
6062	45	65	56
6072	55	81	70
6102	75	113	98
6122	90	137	119
6152	110	162	140
6172	132	201	174
6222	160	253	219
6272	200	303	262
6352	250	360	312
6402	315	418	362

Mains voltage 575 - 600 V

VLT type	Typical shaft output	Max. constant output current, 575 V	Max. constant output kVA, 575
	$P_{VLT.N}$ [kW]	$I_{VLT.N}$ [A]	$S_{VLT.N}$ [kVA]
6002	1.1	2.4	2.4
6003	1.5	2.7	2.7
6004	2.2	3.9	3.9
6005	3.0	4.9	4.9
6006	4.0	6.1	6.1
6008	5.5	9	9.0
6011	7.5	11	11.0
6016	11	17	16.9
6022	15	22	22
6027	18.5	27	27
6032	22	32	32
6042	30	41	41
6052	37	52	52
6062	45	62	62
6072	55	77	77
6102	75	108	108
6122	90	131	130
6152	110	155	154
6172	132	192	289
6222	160	242	241
6272	200	290	288
6352	250	344	343
6402	315	400	398

■ Unpacking and ordering a VLT frequency converter

If you are in doubt as to which frequency converter you have received and which options it contains, use the following to find out.

■ Type code ordering number string

On the basis of your order, the frequency converter is given an ordering number that can be seen from the nameplate on the unit. The number may look as follows:

VLT-6008-H-T4-B20-R3-DL-F10-A00-C0

This means that the frequency converter ordered is a VLT 6008 for three-phase mains voltage of 380-460 V (**T4**) in Bookstyle enclosure IP 20 (**B20**). The hardware variant is with integral RFI filter, classes A & B (**R3**). The frequency converter features a control unit (**DL**) with a PROFIBUS option card (**F10**). No option card (A00) and no conformal coating (C0) Character no. 8 (**H**) indicates the application range of the unit: **H** = HVAC.

IP 00: This enclosure is only available for the larger power sizes of the VLT 6000 HVAC series. It is recommended for installation in standard cabinets.

IP 20 Bookstyle: This enclosure is designed for cabinet installation. It takes up a minimum of space and can be fitted side-by-side without installation of extra cooling equipment.

IP 20/NEMA 1: This enclosure is used as standard enclosure for VLT 6000 HVAC. It is ideal for cabinet installation in areas where a high degree of protection is required. This enclosure also permits side-by-side installation.

IP 54: This enclosure can be fitted direct to the wall. Cabinets are not required. IP 54 units can also be installed side-by-side.

Hardware variant

The units in the programme are available in the following hardware variants:

ST: Standard unit with or without control unit.

Without DC terminals, except for

VLT 6042-6062, 200-240 V

VLT 6016-6072, 525-600 V

SL: Standard unit with DC terminals.

EX: Extended unit with control unit, DC terminals, connection of external 24 V DC supply for back-up of control PCB.

DX: Extended unit with control unit, DC terminals, built-in mains fuses and disconnect, connection of external 24 V DC supply for back-up of control PCB.

PF: Standard unit with 24 V DC supply for back-up of control PCB and built-in main fuses. No DC terminals.

PS: Standard unit with 24 V DC supply for back-up of control PCB. No DC terminals.

PD: Standard unit with 24 V DC supply for back-up of control PCB, built-in main fuses and disconnect. No DC terminals.

RFI filter

Bookstyle units always come *with* an integral RFI filter that complies with EN 55011-B with 20 m screened/armoured motor cable and EN 55011-A1 with 150 m screened/armoured motor cable. Units for mains voltage of 240 V and a motor power of up to and including 3.0 kW (VLT 6005) and units for a mains voltage of 380-460 V and a motor power of up to 7.5 kW (VLT 6011) are always supplied with an integral class A1 & B filter. Units for higher motor power than these (3.0 and 7.5 kW, respectively) can be ordered either with or without an RFI filter.

Control unit (keypad and display)

All types of units in the programme, except for IP21 vlt 6402-6602, 380-460 V and IP 54 units, can be ordered either with or without the control unit. IP 54 units always come *with* a control unit. All types of units in the programme are available with built-in application options including a relay card with four relays or a cascade controller card.

Conformal Coating

All types of units in the programme are available with or without conformal coating of the PCB.

VLT 6402-6602, 380-460 V and VLT 6102-6402, 525-600 V are only available coated.

200-240 V

Typecode	T2	C00	B20	C20	CN1	C54	ST	SL	R0	R1	R3
Position in string	9-10	11-13	11-13	11-13	11-13	11-13	14-15	14-15	16-17	16-17	16-17
1.1 kW/1.5 HP	6002		X	X		X	X				X
1.5 kW/2.0 HP	6003		X	X		X	X				X
2.2 kW/3.0 HP	6004		X	X		X	X				X
3.0 kW/4.0 HP	6005		X	X		X	X				X
4.0 kW/5.0 HP	6006			X		X	X	X	X		X
5.5 kW/7.5 HP	6008			X		X	X	X	X		X
7.5 kW/10 HP	6011			X		X	X	X	X		X
11 kW/15 HP	6016			X		X	X	X	X		X
15 kW/20 HP	6022			X		X	X	X	X		X
18.5 kW/25 HP	6027			X		X	X	X	X		X
22 kW/30 HP	6032			X		X	X	X	X		X
30 kW/40 HP	6042	X			X	X	X		X	X	
37 kW/50 HP	6052	X			X	X	X		X	X	
45 kW/60 HP	6062	X			X	X	X		X	X	

380-460 V

Typecode	T4	C00	B20	C20	CN1	C54	ST	SL	EX	DX	PS	PD	PF	R0	R1	R3
Position in string	9-10	11-13	11-13	11-13	11-13	11-13	14-15	14-15	14-15	14-15	14-15	14-15	14-15	16-17	16-17	16-17
1.1 kW/1.5 HP	6002		X	X		X	X									X
1.5 kW/2.0 HP	6003		X	X		X	X									X
2.2 kW/3.0 HP	6004		X	X		X	X									X
3.0 kW/4.0 HP	6005		X	X		X	X									X
4.0 kW/5.0 HP	6006		X	X		X	X									X
5.5 kW/7.5 HP	6008		X	X		X	X									X
7.5 kW/10 HP	6011		X	X		X	X									X
11 kW/15 HP	6016			X		X	X	X						X		X
15 kW/20 HP	6022			X		X	X	X						X		X
18.5 kW/25 HP	6027			X		X	X	X						X		X
22 kW/30 HP	6032			X		X	X	X						X		X
30 kW/40 HP	6042			X		X	X	X						X		X
37 kW/50 HP	6052			X		X	X	X						X		X
45 kW/60 HP	6062			X		X	X	X						X		X
55 kW/75 HP	6072			X		X	X	X						X		X
75 kW/100 HP	6102			X		X	X	X						X		X
90 kW/125 HP	6122			X		X	X	X						X		X
110 kW/150 HP	6152	X			X	X	X		X	X	X	X	X	X	X	
132 kW/200 HP	6172	X			X	X	X		X	X	X	X	X	X	X	
160 kW/250 HP	6222	X			X	X	X		X	X	X	X	X	X	X	
200 kW/300 HP	6272	X			X	X	X		X	X	X	X	X	X	X	
250 kW/350 HP	6352	X			X	X	X		X	X	X	X	X	X	X	
315 kW/450 HP	6402	X			X	X	X		X	X	X	X	X	X	X	
355 kW/500 HP	6502	X			X	X	X		X	X	X	X	X	X	X	
400 kW/550 HP	6552	X			X	X	X		X	X	X	X	X	X	X	
450 kW/600 HP	6602	X			X	X	X		X	X	X	X	X	X	X	

Voltage

T2: 200-240 VAC

T4: 380-460 VAC

Enclosure

C00: Compact IP 00

B20: Bookstyle IP 20

C20: Compact IP 20

CN1: Compact NEMA 1

C54: Compact IP 54

Hardware variant

ST: Standard

SL: Standard with DC terminals

EX: Extended with 24 V supply and DC terminals

DX: Extended with 24 V supply, DC terminals,

disconnect and fuse

PS: Standard with 24 V supply

PD: Standard with 24 V supply, fuse and disconnect

PF: Standard with 24 V supply and fuse

RFI filter

R0: Without filter

R1: Class A1 filter

R3: Class A1 and B filter



NB!:
NEMA 1 exceeds IP 20

525-600 V

Typecode Position in string	T6 9-10	C00 11-13	C20 11-13	CN1 11-13	ST 14-15	R0 16-17
1.1 kW/1.5 HP	6002		X	X	X	X
1.5 kW/2.0 HP	6003		X	X	X	X
2.2 kW/3.0 HP	6004		X	X	X	X
3.0 kW/4.0 HP	6005		X	X	X	X
4.0 kW/5.0 HP	6006		X	X	X	X
5.5 kW/7.5 HP	6008		X	X	X	X
7.5 kW/10 HP	6011		X	X	X	X
11 kW/15 HP	6016			X	X	X
15 kW/20 HP	6022			X	X	X
18.5 kW/25 HP	6027			X	X	X
22 kW/30 HP	6032			X	X	X
30 kW/40 HP	6042			X	X	X
37 kW/50 HP	6052			X	X	X
45 kW/60 HP	6062			X	X	X
55 kW/75 HP	6072			X	X	X

VLT 6102-6402, 525-600 V

Typecode Position in string	T6 9-10	C00 11-13	CN1 11-13	C54 11-13	ST 14-15	EX 14-15	DX 14-15	PS 14-15	PD 14-15	PF 14-15	R0 16-17	R1 ¹⁾ 16-17
75 kW / 100 HP	6102	X	X	X	X	X	X	X	X	X	X	X
90 kW / 125 HP	6122	X	X	X	X	X	X	X	X	X	X	X
110 kW / 150 HP	6152	X	X	X	X	X	X	X	X	X	X	X
132 kW / 200 HP	6172	X	X	X	X	X	X	X	X	X	X	X
160 kW / 250 HP	6222	X	X	X	X	X	X	X	X	X	X	X
200 kW / 300 HP	6272	X	X	X	X	X	X	X	X	X	X	X
250 kW / 350 HP	6352	X	X	X	X	X	X	X	X	X	X	X
315 kW / 400HP	6402	X	X	X	X	X	X	X	X	X	X	X

1) R1 is not available with DX, PF, PD options.



NB!:
NEMA 1 exceeds IP 20

Voltage

T6: 525-600 VAC

Enclosure

C00: Compact IP 00

C20: Compact IP 20

CN1: Compact NEMA 1

C54: Compact IP 54

Hardware variant

ST: Standard

EX: Extended with 24 V supply and DC terminals

DX: Extended with 24 V supply, DC terminals, disconnect and fuse

PS: Standard with 24 V supply

PD: Standard with 24 V supply, fuse and disconnect

PF: Standard with 24 V supply and fuse

RFI filter

R0: Without filter

R1: Class A1 filter

Optional selections, 200-600 V

Display		Position: 18-19
D0 ¹⁾	Without LCP	
DL	With LCP	
Fieldbus option		Position: 20-22
F00	No options	
F10	Profibus DP V1	
F13	Profibus FMS	
F30	DeviceNet	
F40	LonWorks free topology	
F41	LonWorks 78 kBps	
F42	LonWorks 1.25 MBps	
Application option		Position: 23-25
A00	No options	
A31 ²⁾	Relay card 4 relays	
A32	Cascade Controller	
A40	Real Time Clock	
Coating		Position: 26-27
C0 ³⁾	No coating	
C1	With coating	

1) Not available with enclosure compact IP 54

2) Not available with fieldbus options (Fxx)

3) Not available for power sizes from 6402 to 6602, 380-460 V and 6102-6402, 525-600 V

■ Ordering form

VLT 6 H T R D F A C

Power sizes
e.g. 6008

Application range
H

Mains voltage
T2
T4
T6

Enclosure
B20
C00
C20
C54
CN1

Hardware variant
ST
SL
PS
PD
PF
EX
DX

RFI filter
R0
R1
R3

Display unit (LCP)
D0
DL

Fieldbus option card
F00
F10
F13
F30
F40
F41
F42

Application option card
A00
A31
A32
A40

Coating
C0
C1

6002
6003
6004
6005
6006
6008
6011
6016
6022
6027
6032
6042
6052
6062
6072
6102
6122
6152
6172
6222
6272
6352
6402
6502
6552
6602

No. units of this type

Required delivery date

Ordered by:

Date: _____

Take a copy of the ordering forms.
Fill them in and send or fax your order to the nearest office of the Danfoss sales organisation

175ZA895.15

■ PC software and serial communication

Danfoss offers various options for serial communication.

Using serial communication, it is possible to monitor, program and control one or several frequency converters from a centrally located computer.

All VLT 6000 HVAC units have a RS 485 port as standard with a choice of four protocols. The protocols selectable in parameter 500 *Protocols* are:

- FC protocol
- Johnson Controls Metasys N2
- Landis/Staefa Apogee FLN
- Modbus RTU

A bus option card allows higher transmission speed than RS 485. In addition, a higher number of units can be linked to the bus and alternative transmission media can be used. Danfoss offers the following option cards for communication:

- Profibus
- LonWorks
- DeviceNet

Information on the installation of various options is not included in this manual.

Using the RS 485 port enables communication, e.g. with a PC. A Windows™ program, called *MCT 10*, is available for this purpose. It can be used to monitor, program and control one or several VLT 6000 HVAC units. For further information, see the *Design Guide* for VLT 6000 HVAC or contact Danfoss.

500-566 Serial communication

**NB!:**

Information on the use of RS-485 serial interface is not included in this manual. For further information, see the *Design Guide* for VLT 6000 HVAC or contact Danfoss.

■ PC Software tools**PC Software - MCT 10**

All drives are equipped with a serial communication port. We provide a PC tool for communication between PC and frequency converter, VLT Motion Control Tool MCT 10 Set-up Software.

MCT 10 Set-up Software

MCT 10 has been designed as an easy to use interactive tool for setting parameters in our frequency converters. The MCT 10 Set-up Software will be useful for:

- Planning a communication network off-line. MCT 10 contains a complete frequency converter database
- Commissioning frequency converters on line
- Saving settings for all frequency converters
- Replacing a drive in a network
- Expanding an existing network
- Future developed drives will be supported

MCT 10 Set-up Software support Profibus DP-V1 via a Master class 2 connection. It makes it possible to

on line read/write parameters in a frequency converter via the Profibus network. This will eliminate the need for an extra communication network.

The MCT 10 Set-up Software Modules

The following modules are included in the software package:

**MCT 10 Set-up Software**

Setting parameters
Copy to and from frequency converters
Documentation and print out of parameter settings incl. diagrams

SyncPos

Creating SyncPos programme

Ordering number:

Please order your CD containing MCT 10 Set-up Software using code number 130B1000.

MCT 31

The MCT 31 harmonic calculation PC tool enables easy estimation of the harmonic distortion in a given application. Both the harmonic distortion of Danfoss frequency converters as well as non-Danfoss frequency converters with different additional harmonic reduction

measurements, such as Danfoss AHF filters and 12-18-pulse rectifiers, can be calculated.

Ordering number:

Please order your CD containing the MCT 31 PC tool using code number 130B1031.

■ Fieldbus options

The increasing need for information in building management systems makes it necessary to collect or visualise many different types of process data. Important process data can help the system technician in the day to day monitoring of the system, which means that a negative development, e. g. an increase in energy consumption, can be rectified in time.

The substantial amount of data in large buildings may generate a need for a higher transmission speed than 9600 baud.

■ Profibus

Profibus is a fieldbus system with FMS and DP, which can be used for linking automation units, such as sensors and actuators, to the controls by means of a two-conductor cable.

Profibus **FMS** is used if major communication tasks are to be solved at cell and system level by means of large volumes of data.

Profibus **DP** is an extremely fast communication protocol, made specially for communication between the automation system and various units.

■ LON - Local Operating Network

LonWorks is an intelligent fieldbus system which improves the possibility of decentralising control, as communication is enabled between individual units in the same system (Peer-to-Peer).

This means that there is no need for a big main station for handling all the signals of the system (Master-Slave). Signals are sent direct to the unit that needs them via a common network medium. This makes

communication much more flexible and the central building state control and monitoring system can be changed into a dedicated building state monitoring system whose task is to ensure that everything is running as planned. If the potential of LonWorks is fully utilised, sensors will also be connected to the bus, which means that a sensor signal can quickly be moved to another controller. If room dividers are mobile, this is a particularly useful feature.

■ DeviceNet

DeviceNet is a digital, multi-drop network, based on the CAN protocol, that connects and serves as a communication network between industrial controllers and I/O devices.

Each device and/or controller is a node on the network. DeviceNet is a producer-consumer network that supports multiple communication hierarchies and message prioritization.

DeviceNet systems can be configured to operate in a master-slave or a distributed control architecture using peer-to-peer communication. This system offers a single point of connection for configuration and control by supporting both I/O and explicit messaging.

DeviceNet also has the feature of having power on the network. This allows devices with limited power requirements to be powered directly from the network via the 5-conductor cable.

■ Modbus RTU

MODBUS RTU (Remote Terminal Unit) Protocol is a messaging structure developed by Modicon in 1979, used to establish master-slave/client-server communication between intelligent devices.

MODBUS is used to monitor and program devices; to communicate intelligent devices with sensors and instruments; to monitor field devices using PCs and HMI's.

MODBUS is often applied in Gas and Oil applications, but also in building, infrastructure, transportation and energy, applications are making use of its benefits.

■ Accessories for VLT 6000 HVAC

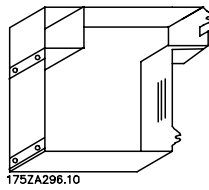
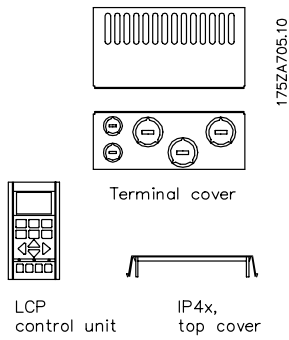

IP 20 bottom cover

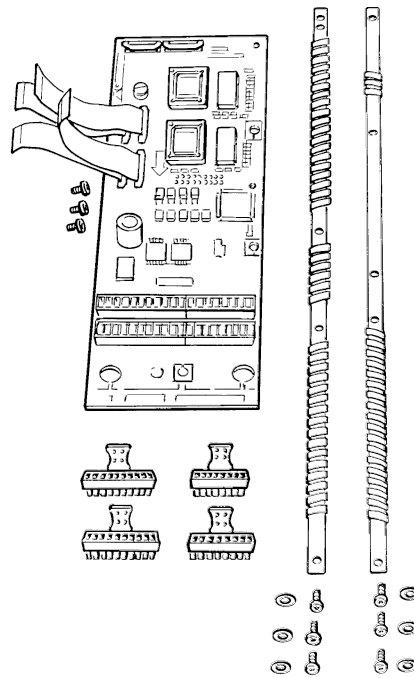

Application option

■ Ordering numbers, misc.

Type	Description	Order no.
IP 4x top cover ¹⁾	Option, VLT type 6002-6005 200-240 V compact	175Z0928
IP 4x top cover IP ¹⁾	Option, VLT type 6002-6011 380-460 V compact	175Z0928
IP 4 x top cover ¹⁾	Option, VLT type 6002-6011 525-600 V compact	175Z0928
NEMA 12 bonding plate ²⁾	Option, VLT type 6002-6005 200-240 V	175H4195
NEMA 12 bonding plate ²⁾	Option, VLT type 6002-6011 380-460 V	175H4195
IP 20 terminal cover	Option, VLT type 6006-6022 200-240 V	175Z4622
IP 20 terminal cover	Option, VLT type 6027-6032 200-240 V	175Z4623
IP 20 terminal cover	Option, VLT type 6016-6042 380-460 V	175Z4622
IP 20 terminal cover	Option, VLT type 6016-6042 525-600 V	175Z4622
IP 20 terminal cover	Option, VLT type 6052-6072 380-460 V	175Z4623
IP 20 terminal cover	Option, VLT type 6102-6122 380-460 V	175Z4280
IP 20 terminal cover	Option, VLT type 6052-6072 525-600 V	175Z4623
IP 20 bottom cover	Option, VLT type 6042-6062 200-240 V	176F1800
Terminal adaptor kit	VLT type 6042-6062 200-240 V, IP 54	176F1808
Terminal adaptor kit	VLT type 6042-6062 200-240 V, IP 20/NEMA 1	176F1805
Control panel LCP	Separate LCP	175Z7804
LCP remote-mounting kit IP 00 & 20 ³⁾	Remote-mounting kit, incl. 3 m cable	175Z0850
LCP remote-mounting kit IP 54 ⁴⁾	Remote-mounting kit, incl. 3 m cable	175Z7802
LCP blind cover	for all IP00/IP20 drives	175Z7806
Cable for LCP	Separate cable, 3 m	175Z0929
Relay card	Application card with four relay outputs	175Z7803
Cascade controller card	With conformal coating	175Z3100
Real Time Clock Option	Without/with conformal coating	175Z4852/175Z4853
Profibus option	Without/with conformal coating	175Z7800/175Z2905
LonWorks option, Free topology	Without/with conformal coating	176F1515/176F1521
LonWorks option, 78 KBPS	Without/with conformal coating	176F1516/176F1522
LonWorks option, 1.25 MBPS	Without/with conformal coating	176F1517/176F1523
Modbus RTU option	Without conformal coating	175Z3362
DeviceNet option	Without/with conformal coating	176F1586/176F1587
MCT 10 Set-up software	CD-Rom	130B1000
MCT 31 Harmonic calculation	CD-Rom	130B1031

Rittal Installation Kit

Type	Description	Order No.
Rittal TS8 enclosure for IP00 ⁵⁾	Installation kit for 1800mm high enclosure, VLT6152-6172, 380-460V, VLT 6102-6172, 525-600 V	176F1824
Rittal TS8 enclosure for IP00 ⁵⁾	Installation kit for 2000mm high enclosure, VLT6152-6172, 380-460V, VLT 6102-6172, 525-600 V	176F1826
Rittal TS8 enclosure for IP00 ⁵⁾	Installation kit for 1800mm high enclosure, VLT6222-6352, 380-460V, VLT 6222-6402, 525-600 V	176F1823
Rittal TS8 enclosure for IP00 ⁵⁾	Installation kit for 2000mm high enclosure, VLT6222-6352, 380-460V, VLT 6222-6402, 525-600 V	176F1825
Rittal TS8 enclosure for IP00 ⁵⁾	Installation kit for 2000mm high enclosure, VLT6402-6602, 380-460V	176F1850
Floor stand for IP21 and IP54 enclosure ⁵⁾	Option, VLT6152-6352, 380-460V, VLT 6102-6402, 525-600 V	176F1827
Mains shield kit	Protection kit: for VLT 6152-6352, 380-460V, VLT 6102-6402, 525-600V	176F0799
Mains shield kit	Protection kit for VLT 6402-6602, 380-460V	176F1851

- 1) IP 4x/NEMA 1 top cover is for IP 20 units only and only horizontal surfaces comply with IP 4x. The kit also contains a bonding plate (UL).
- 2) NEMA 12 bonding plate (UL) is only for IP 54 units.
- 3) The remote-mounting kit is only for IP 00 and IP 20 units. Enclosure of the remote-mounting kit is IP 65.
- 4) The remote-mounting kit is only for IP 54 units. Enclosure of the remote-mounting kit is IP 65.
- 5) For details: See High Power Installation Guide, MI.90.JX.YY.

VLT 6000 HVAC is available with an integral fieldbus option or application option. Ordering numbers for the individual VLT types with integrated options can be seen from the relevant manuals or instructions. In addition, the ordering number system can be used for ordering a frequency converter with an option.

- Control panel LCP (only for IP 20 units).
- LCP remote-mounting kit for remote control of IP 00 and IP 20 units.
- LCP remote-mounting kit for remote control of IP 54.
- 3 metre cable for LCP.

■ Control unit (LCP)

The VLT 6000 HVAC is available with or without control unit (LCP); however, IP 54 units always come with the control unit.

This control unit makes up a complete interface for control and programming of the VLT 6000 HVAC. The control panel is detachable and may - as an alternative - be mounted up to 3 metres away from the frequency converter, i.e. in a cabinet, by means of a fitting kit delivered with the unit.

Data information is given in a 4-line alpha-numerical display, which under normal operation is able to continuously show four operating data items and three operating modes. During programming, all the information required for quickly and efficiently setting up frequency converter parameters will be shown.

As a supplement to the display, there are three indicator lamps for voltage (ON), warning (WARNING) and alarm (ALARM).

All frequency converter parameter Setups can be changed directly via the control panel.

The following options are available:

■ LC filters for VLT 6000 HVAC

When a motor is controlled by a frequency converter, resonance noise will be heard from the motor. This noise, which is caused by the design of the motor, occurs each time one of the inverter switches in the frequency converter is activated. Consequently, the resonance noise frequency corresponds to the switching frequency of the frequency converter.

For the VLT 6000 HVAC, Danfoss offers a LC filter to dampen the acoustic motor noise.

This filter reduces the voltage rise time, the peak voltage U_{PEAK} and the ripple current ΔI to the motor, thereby making current and voltage almost sinusoidal. The acoustic motor noise is therefore reduced to a minimum.

Because of the ripple current in the coils, there will be some noise from the coils. This problem can be solved entirely by integrating the filter in a cabinet or similar.

■ Harmonic filter

Harmonic currents do not directly affect the electricity consumption but has an impact on following conditions:

Higher total current to be handled by the installations

- Increases load on transformer (sometimes it will require a larger transformer, particular at retrofit)
- Increases heat losses in transformer and installation
- In some cases demands larger cables, switches and fuses

Higher voltage distortion due to higher current

- Increase risk for disturbing electronic equipment connected to same grid

A high percentage of rectifier load from eg frequency converters, will increase the harmonic current, which must be reduced to avoid the above consequences. Therefore the frequency converter has as standard, built in DC coils reducing the total current with about 40% (compared to devices without any arrangement for harmonic suppression), down to 40-45% THiD.

In some cases there is a need for further suppression (eg retrofit with frequency converters). For this purpose Danfoss can offer two advanced harmonic filters AHF05 and AHF10, bringing the harmonic current down to around 5% and 10% respectively. For further details see instruction MG.80.BX.YY.

Well pumps

If immersion pumps are used, e.g. submerged pumps or well pumps, the supplier should be contacted for clarification of requirements. It is recommended to use a LC filter if a frequency converter is used for well pump applications.

■ Examples of the use of LC filtersSubmersible pumps

For small motors with up to and including 5.5 kW rated motor power, use an LC filter, unless the motor is equipped with phase separation paper. This applies e.g. to all wet running motors. If these motors are used without LC filter in connection with a frequency converter, the motor windings will short-circuit. If in doubt, ask the motor manufacturer whether the motor in question is equipped with phase separation paper.

■ Ordering numbers, LC filter modules
Mains supply 3 x 200 - 240 V

LC filter for VLT type	LC filter enclosure	Rated current at 200 V	Max. output frequency	Power loss	Order no.
6002-6003	IP 20 Bookstyle	7.8 A	120 Hz		175Z0825
6004-6005	IP 20 Bookstyle	15.2 A	120 Hz		175Z0826
6002-6005	IP 20	15.2 A	120 Hz		175Z0832
6006-6008	IP 00	25.0 A	60 Hz	110 W	175Z4600
6011	IP 00	32 A	60 Hz	120 W	175Z4601
6016	IP 00	46 A	60 Hz	150 W	175Z4602
6022	IP 00	61 A	60 Hz	210 W	175Z4603
6027	IP 00	73 A	60 Hz	290 W	175Z4604
6032	IP 00	88 A	60 Hz	320 W	175Z4605
6042	IP 20	115 A	60 Hz	600 W	175Z4702
6052	IP 20	143 A	60 Hz	600 W	175Z4702
6062	IP 20	170 A	60 Hz	750 W	175Z4703

Mains supply 3 x 380 - 460

LC filter for VLT type	LC filter enclosure	Rated current at 400/460 V	Max. output frequency	Power loss	Order no.
6002-6005	IP 20 Bookstyle	7.2 A / 6.3 A	120 Hz		175Z0825
6006-6011	IP 20 Bookstyle	16 A / 16 A	120 Hz		175Z0826
6002-6011	IP 20	16 A / 16 A	120 Hz		175Z0832
6016	IP 00	24 A / 21.7 A	60 Hz	170 W	175Z4606
6022	IP 00	32 A / 27.9 A	60 Hz	180 W	175Z4607
6027	IP 00	37.5 A / 32 A	60 Hz	190 W	175Z4608
6032	IP 00	44 A / 41.4 A	60 Hz	210 W	175Z4609
6042	IP 00	61 A / 54 A	60 Hz	290 W	175Z4610
6052	IP 00	73 A / 65 A	60 Hz	410 W	175Z4611
6062	IP 00	90 A / 78 A	60 Hz	480 W	175Z4612
6072	IP 20	106 A / 106 A	60 Hz	500 W	175Z4701
6102	IP 20	147 A / 130 A	60 Hz	600 W	175Z4702
6122	IP 20	177 A / 160 A	60 Hz	750 W	175Z4703
6152	IP 20	212 A / 190 A	60 Hz	900 W	175Z4704
6172	IP 20	260 A / 240 A	60 Hz	1000 W	175Z4705
6222	IP 20	315 A / 302 A	60 Hz	1100 W	175Z4706
6272	IP 20	395 A / 361 A	60 Hz	1700 W	175Z4707
6352	IP 20	480 A / 443 A	60 Hz	2100 W	175Z3139
6402	IP 20	600 A / 540 A	60 Hz	2100 W	175Z3140
6502	IP 20	658 A / 590 A	60 Hz	2500 W	175Z3141
6552	IP 20	745 A / 678 A	60 Hz		175Z3142

Regarding LC filters for 525 - 600 V and VLT 6602 380-460 V, please contact Danfoss.

NB!:

When using LC filters, the switching frequency must be 4.5 kHz (see parameter 407).

For VLT 6102-6602 parameter 408 must be set to *LC filter fitted* to obtain proper operation.

■ LC filters 6002-6005, 200 - 240 V / 6002-6011 380 - 460 V

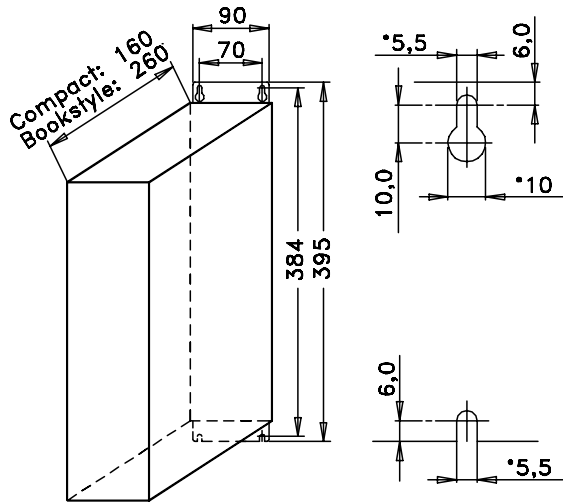

175ZA106.11

The drawing on the left gives the measurements of IP 20 LC filters for the above-mentioned power range. Min. space above and under enclosure: 100 mm.

IP 20 LC filters have been designed for side-by-side installation without any space between enclosures.

Max. motor cable length:

- 150 m screened/armoured cable
- 300 m unscreened/unarmoured cable

If EMC standards are to be complied with:

EN 55011-1B: Max. 50 screened/armoured cable

Bookstyle: Max. 20 m screened/armoured cable

EN 55011-1A: Max. 150 m screened/armoured cable

Weight:	175Z0825	7.5 kg
	175Z0826	9.5 kg
	175Z0832	9.5 kg

■ Installation of LC filter IP 20 Bookstyle

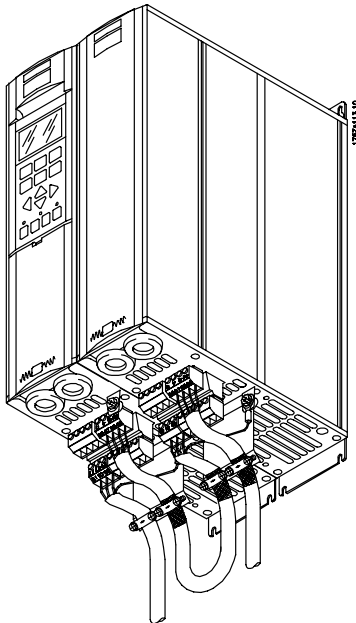

■ Installation of LC filter IP 20

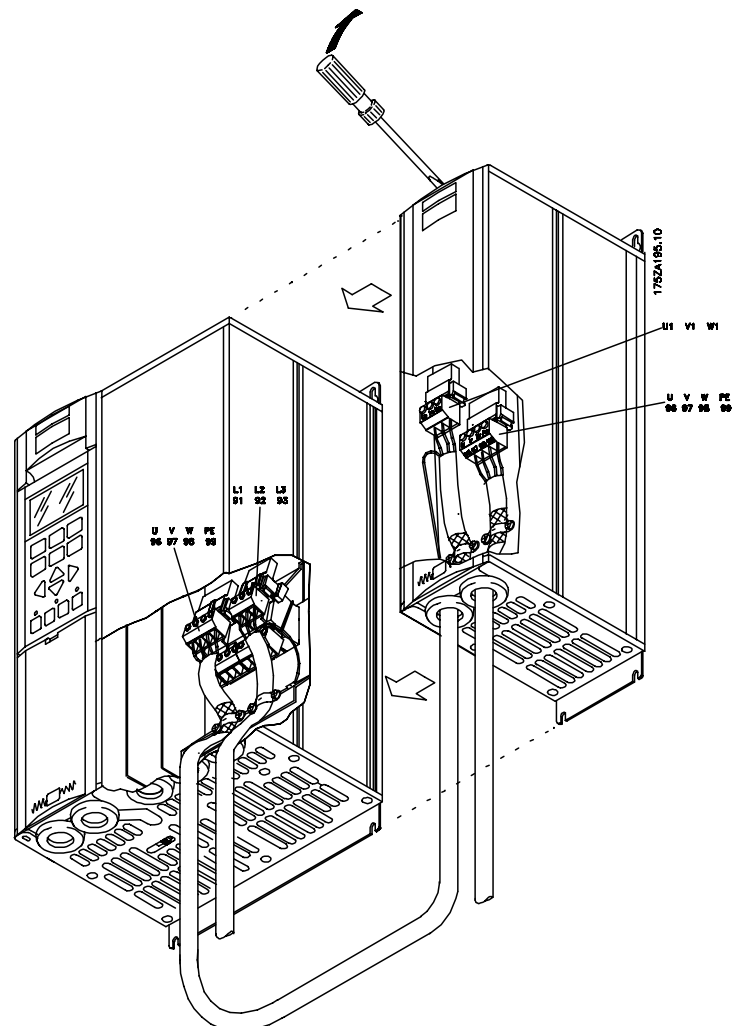

■ LC filters VLT 6006-6032, 200 - 240 V /
6016-6062 380 - 460 V

The table and the drawing give the measurements of IP 00 LC filters for Compact units.

IP 00 LC filters must be integrated and protected against dust, water and corrosive gases.

Max. motor cable length:

- 150 m screened/armoured cable
- 300 m unscreened/unarmoured cable

If EMC standards are to be complied with:

- EN 55011-1B: Max. 50 screened/armoured cable
- Bookstyle: Max. 20 m screened/armoured cable
- EN 55011-1A: Max. 150 m screened/armoured cable

LC filter IP 00

LC type	A [mm]	B [mm]	C [mm]	D [mm]	E [mm]	F [mm]	G [mm]	Weight [kg]
175Z4600	220	135	92	190	68	170	8	10
175Z4601	220	145	102	190	78	170	8	13
175Z4602	250	165	117	210	92	180	8	17
175Z4603	295	200	151	240	126	190	11	29
175Z4604	355	205	152	300	121	240	11	38
175Z4605	360	215	165	300	134	240	11	49
175Z4606	280	170	121	240	96	190	11	18
175Z4607	280	175	125	240	100	190	11	20
175Z4608	280	180	131	240	106	190	11	23
175Z4609	295	200	151	240	126	190	11	29
175Z4610	355	205	152	300	121	240	11	38
175Z4611	355	235	177	300	146	240	11	50
175Z4612	405	230	163	360	126	310	11	65

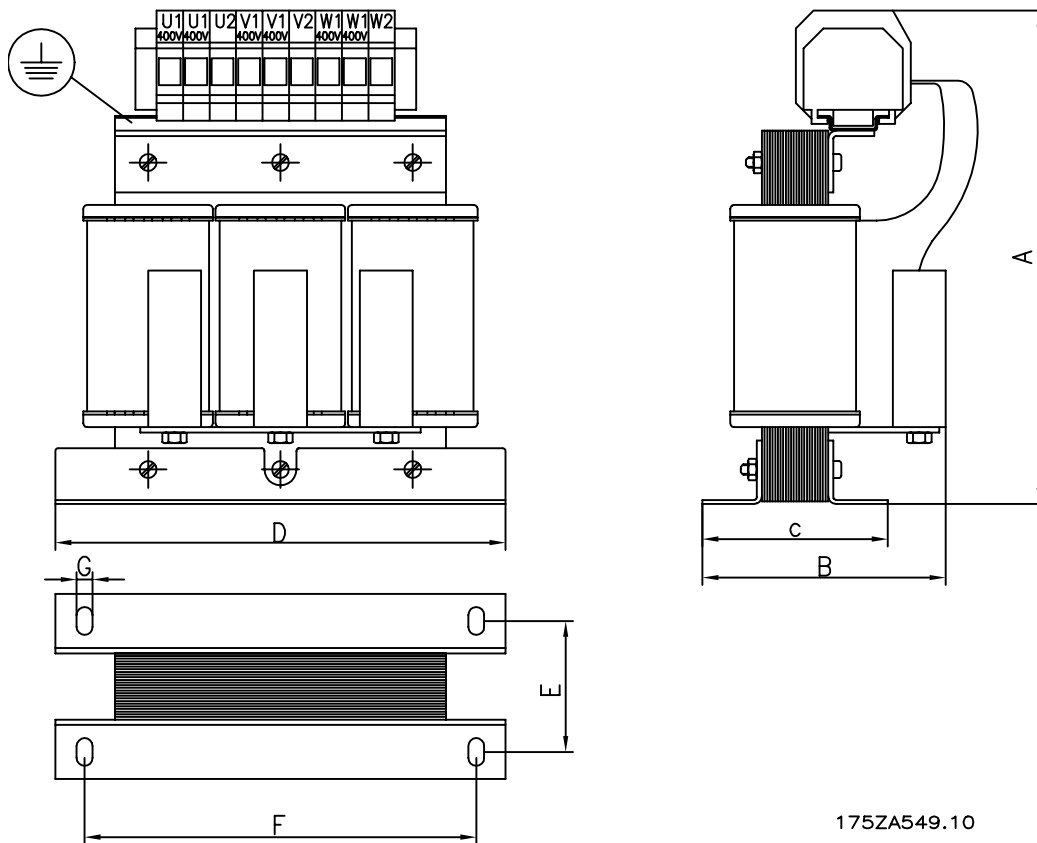

■ LC filter VLT 6042-6062 200-240 V / VLT 6072-6552 380-460 V

The table and the drawing give the measurements of IP 20 LC filters. IP 20 LC filters must be integrated and protected against dust, water and aggressive gases.

Max. motor cable length:

- 150 m screened/armoured cable
- 300 m unscreened/unarmoured cable

If EMC standards are to be complied with:

- EN 55011-1B: Max. 50 m screened/armoured cable

Bookstyle: Max. 20 m screened/armoured cable

- EN 55011-1A: Max. 150 m screened/armoured cable

LC-filter IP 20

LC type	A [mm]	B [mm]	C [mm]	D [mm]	E [mm]	F [mm]	G [mm]	Weight [kg]
175Z4701	740	550	600					70
175Z4702	740	550	600					70
175Z4703	740	550	600					110
175Z4704	740	550	600					120
175Z4705	830	630	650					220
175Z4706	830	630	650					250
175Z4707	830	630	650					250
175Z3139	1350	800	1000					350
175Z3140	1350	800	1000					400
175Z3141	1350	800	1000					400
175Z3142	1350	800	1000					470

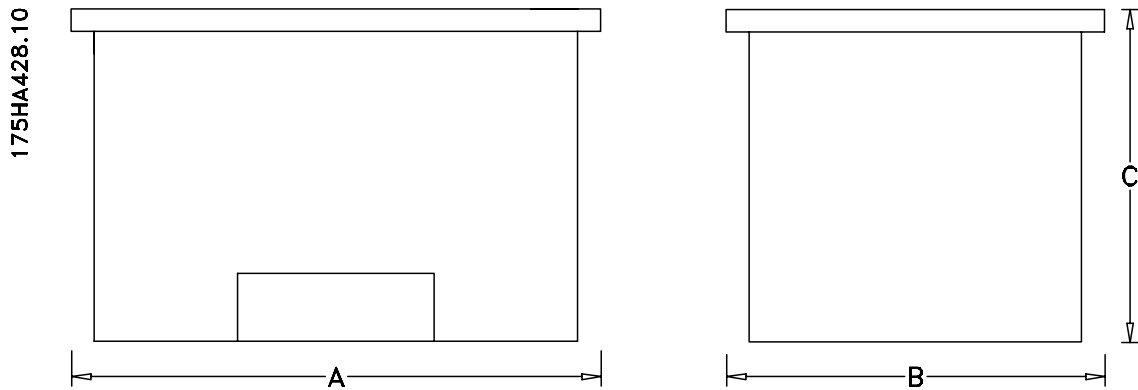

■ Ordering numbers, Harmonic filters

Harmonic filters are used to reduce mains harmonics

- AHF 010: 10% current distortion
- AHF 005: 5% current distortion

380-415V, 50Hz

I _{AHF,N}	Typical Motor Used [kW]	Danfoss ordering number		VLT 6000
		AHF 005	AHF 010	
10 A	4, 5.5	175G6600	175G6622	6006, 6008
19 A	7.5	175G6601	175G6623	6011, 6016
26 A	11	175G6602	175G6624	6022
35 A	15, 18.5	175G6603	175G6625	6027
43 A	22	175G6604	175G6626	6032
72 A	30, 37	175G6605	175G6627	6042, 6052
101 A	45, 55	175G6606	175G6628	6062, 6072
144 A	75	175G6607	175G6629	6102
180 A	90	175G6608	175G6630	6122
217 A	110	175G6609	175G6631	6152
289 A	132, 160	175G6610	175G6632	6172, 6222
324 A		175G6611	175G6633	
370 A	200	175G6688	175G6691	6272
Higher ratings can be achieved by paralleling the filter units				
434 A	250	Two 217 A units		6352
578 A	315	Two 289 A units		6402
613 A	355	289 A and 324 A units		6502
648 A	400	Two 324 A units		6552
740 A	450	Two 324 A units		6602

440-480V, 60Hz

I _{AHF,N}	Typical Motor Used [HP]	Danfoss ordering number		VLT 6000
		AHF 005	AHF 010	
19 A	10, 15	175G6612	175G6634	6011, 6016
26 A	20	175G6613	175G6635	6022
35 A	25, 30	175G6614	175G6636	6027, 6032
43 A	40	175G6615	175G6637	6042
72 A	50, 60	175G6616	175G6638	6052, 6062
101 A	75	175G6617	175G6639	6072
144 A	100, 125	175G6618	175G6640	6102, 6122
180 A	150	175G6619	175G6641	6152
217 A	200	175G6620	175G6642	6172
289 A	250	175G6621	175G6643	6222
324 A	300	175F6689	175G6692	6272
397 A	350	175G6690	175G6693	6352
Higher ratings can be achieved by paralleling the filter units				
506 A	450	217 A and 289 A units		6402
578 A	500	Two 289 A units		6502
578 A	550	Two 289 A units		6552
648 A	600	Two 324 A units		6602

Please note that the matching of the Danfoss frequency converter and filter is pre-calculated based on 400V/480V and assuming typical motor load (4 pole) and 110 % torque. For other combinations, please consult MG.80.BX.YY.

■ Installation

■ Mains supply (L1, L2, L3)

Mains supply (L1, L2, L3):

Supply voltage 200-240 V units	3 x 200/208/220/230/240 V ±10%
Supply voltage 380-460 V units	3 x 380/400/415/440/460 V ±10%
Supply voltage 525-600 V units	3 x 525/550/575/600 V ±10%
Supply frequency	48-62 Hz ± 1%

Max. imbalance of supply voltage:

VLT 6002-6011, 380-460 V and 525-600 V and VLT 6002-6005, 200-240 V	±2.0% of rated supply voltage
VLT 6016-6072, 380-460 V and 525-600 V and VLT 6006-6032, 200-240 V	±1.5% of rated supply voltage
VLT 6102-6602, 380-460 V and VLT 6042-6062, 200-240 V	±3.0% of rated supply voltage
VLT 6102-6402, 525-600 V	±3% of rated supply voltage
True Power factor (λ)	0.90 nominal at rated load
Displacement Power Factor (cos. ϕ)	near unity (>0.98)
No. of switches on supply input L1, L2, L3	approx. 1 time/2 min.
Max. short-circuit current	100.000 A

VLT output data (U, V, W):

Output voltage	0-100% of supply voltage
Output frequency:	
Output frequency 6002-6032, 200-240V	0-120 Hz, 0-1000 Hz
Output frequency 6042-6062, 200-240V	0-120 Hz, 0-450 Hz
Output frequency 6002-6062, 380-460V	0-120 Hz, 0-1000 Hz
Output frequency 6072-6602, 380-460V	0-120 Hz, 0-450 Hz
Output frequency 6002-6016, 525-600V	0-120 Hz, 0-1000 Hz
Output frequency 6022-6062, 525-600V	0-120 Hz, 0-450 Hz
Output frequency 6072, 525-600V	0-120 Hz, 0-450 Hz
Output frequency 6102-6352, 525-600V	0-132 Hz, 0-200 Hz
Output frequency 6402, 525-600V	0-132 Hz, 0-150 Hz
Rated motor voltage, 200-240 V units	200/208/220/230/240 V
Rated motor voltage, 380-460 V units	380/400/415/440/460 V
Rated motor voltage, 525-600 V units	525/550/575 V
Rated motor frequency	50/60 Hz
Switching on output	Unlimited
Ramp times	1 - 3600 sec.

Torque characteristics:

Starting torque	110% for 1 min.
Starting torque (parameter 110 <i>High break-away torque</i>)	Max. torque: 160% for 0.5 sec.
Acceleration torque	100%
Overload torque	110%

Control card, digital inputs:

Number of programmable digital inputs	8
Terminal nos.	16, 17, 18, 19, 27, 29, 32, 33
Voltage level	0-24 V DC (PNP positive logics)
Voltage level, logical '0'	< 5 V DC
Voltage level, logical '1'	>10 V DC
Maximum voltage on input	28 V DC
Input resistance, R_i	2 k

Scanning time per input 3 msec.

Reliable galvanic isolation: All digital inputs are galvanically isolated from the supply voltage (PELV). In addition, the digital inputs can be isolated from the other terminals on the control card by connecting an external 24 V DC supply and opening switch 4. See Switches 1-4.

Control card, analogue inputs

No. of programmable analogue voltage inputs/thermistor inputs 2
 Terminal nos. 53, 54
 Voltage level 0 - 10 V DC (scalable)
 Input resistance, R_i approx. 10 k
 No. of programmable analogue current inputs 1
 Terminal no ground. 55
 Current range 0/4 - 20 mA (scalable)
 Input resistance, R_i 200
 Resolution 10 bit + sign
 Accuracy on input Max. error 1% of full scale
 Scanning time per input 3 msec.

Reliable galvanic isolation: All analogue inputs are galvanically isolated from the supply voltage (PELV) and other high-voltage terminals.

Control card, pulse input:

No. of programmable pulse inputs 3
 Terminal nos. 17, 29, 33
 Max. frequency on terminal 17 5 kHz
 Max. frequency on terminals 29, 33 20 kHz (PNP open collector)
 Max. frequency on terminals 29, 33 65 kHz (Push-pull)
 Voltage level 0-24 V DC (PNP positive logics)
 Voltage level, logical '0' < 5 V DC
 Voltage level, logical '1' >10 V DC
 Maximum voltage on input 28 V DC
 Input resistance, R_i 2 k
 Scanning time per input 3 msec.
 Resolution 10 bit + sign
 Accuracy (100-1 kHz), terminals 17, 29, 33 Max. error: 0.5% of full scale
 Accuracy (1-5 kHz), terminal 17 Max. error: 0.1% of full scale
 Accuracy (1-65 kHz), terminals 29, 33 Max. error: 0.1% of full scale

Reliable galvanic isolation: All pulse inputs are galvanically isolated from the supply voltage (PELV). In addition, pulse inputs can be isolated from the other terminals on the control card by connecting an external 24 V DC supply and opening switch 4. See Switches 1-4.

Control card, digital/pulse and analogue outputs:

No. of programmable digital and analogue outputs 2
 Terminal nos. 42, 45
 Voltage level at digital/pulse output 0 - 24 V DC
 Minimum load to ground (terminal 39) at digital/pulse output 600
 Frequency ranges (digital output used as pulse output) 0-32 kHz
 Current range at analogue output 0/4 - 20 mA
 Maximum load to ground (terminal 39) at analogue output 500
 Accuracy of analogue output Max. error: 1.5% of full scale
 Resolution on analogue output. 8 bit

Reliable galvanic isolation: All digital and analogue outputs are galvanically isolated from the supply voltage (PELV) and other high-voltage terminals.

Control card, 24 V DC supply:

Terminal nos.	12, 13
Max. load	200 mA
Terminal nos. ground	20, 39

Reliable galvanic isolation: The 24 V DC supply is galvanically isolated from the supply voltage (PELV), but has the same potential as the analogue outputs.

Control card, RS 485 serial communication:

Terminal nos.	68 (TX+, RX+), 69 (TX-, RX-)
--------------------	------------------------------

Reliable galvanic isolation: Full galvanic isolation (PELV).

Relay outputs:1)

No. of programmable relay outputs	2
Terminal nos., control card (resistive load only)	4-5 (make)
Max. terminal load (AC1) on 4-5, control card	50 V AC, 1 A, 50 VA
Max. terminal load (DC1 (IEC 947)) on 4-5, control card	25 V DC, 2 A / 50 V DC, 1 A, 50 W
Max. terminal load (DC1) on 4-5, control card for UL/cUL applications	30 V AC, 1 A / 42.5 V DC, 1A
Terminal nos., power card (resistive and inductive load)	1-3 (break), 1-2 (make)
Max. terminal load (AC1) on 1-3, 1-2, power card	250 V AC, 2 A, 500 VA
Max. terminal load (DC1 (IEC 947)) on 1-3, 1-2, power card	25 V DC, 2 A / 50 V DC, 1A, 50 W
Min. terminal load (AC/DC) on 1-3, 1-2, power card	24 V DC, 10 mA / 24 V AC, 100 mA

1) Rated values for up to 300,000 operations.

At inductive loads the number of operations are reduced by 50%, alternatively the current can be reduced by 50%, thus the 300,000 operations are maintained.

External 24 Volt DC supply (only available with VLT 6152-6602, 380-460 V):

Terminal nos.	35, 36
Voltage range	24 V DC ±15% (max. 37 V DC for 10 sec.)
Max. voltage ripple	2 V DC
Power consumption	15 W - 50 W (50 W for start-up, 20 msec.)
Min. pre-fuse	6 Amp

Reliable galvanic isolation: Full galvanic isolation if the external 24 V DC supply is also of the PELV type.

Cable lengths and cross-sections:

Max. motor cable length, screened cable	150 m
Max. motor cable length, unscreened cable	300 m
Max. motor cable length, screened cable VLT 6011 380-460 V	100 m
Max. motor cable length, screened cable VLT 6011 525-600 V	50 m
Max. DC-bus cable length, screened cable	25 m from frequency converter to DC bar.
<i>Max. cable cross-section to motor, see next section</i>	
Max. cross-section for 24 V external DC supply	2.5 mm ² /12 AWG
Max. cross-section for control cables	1.5 mm ² /16 AWG
Max. cross-section for serial communication	1.5 mm ² /16 AWG

If UL/cUL is to be complied with, copper cable with temperature class 60/75°C must be used (VLT 6002 - 6072 380 - 460 V, 525-600 V and VLT 6002 - 6032 200 - 240 V).

If UL/cUL is to be complied with, copper cable with temperature class 75°C must be used (VLT 6042 - 6062 200 - 240 V, VLT 6102 - 6602 380 - 460 V, VLT 6102 - 6402 525 - 600 V).

Connectors are for use of both copper and aluminium cables, unless other is specified.

Control characteristics:

Frequency range	0 - 1000 Hz
Resolution on output frequency	±0.003 Hz
System response time	3 msec.
Speed, control range (open loop)	1:100 of synchro. speed
Speed, accuracy (open loop)	< 1500 rpm: max. error ± 7.5 rpm
>1500 rpm: max. error of 0.5% of actual speed	
Process, accuracy (closed loop)	< 1500 rpm: max. error ± 1.5 rpm
>1500 rpm: max. error of 0.1% of actual speed	

All control characteristics are based on a 4-pole asynchronous motor

Accuracy of display readout (parameters 009-012, Display readout):

Motor current [5] 0-140% load	Max. error: ±2.0% of rated output current
Power kW [6], Power HP [7], 0-90% load	Max. error: ±5% of rated output power

Externals:

Enclosure	IP 00, IP 20, IP 21/NEMA 1, IP 54
Vibration test	0.7 g RMS 18-1000 Hz random. 3 directions for 2 hours (IEC 68-2-34/35/36)
Max. relative humidity	93 % + 2 %, -3 % (IEC 68-2-3) for storage/transport
Max. relative humidity	95 % non condensing (IEC 721-3-3; class 3K3) for operation
Aggressive environment (IEC 721-3-3)	Uncoated class 3C2
Aggressive environment (IEC 721-3-3)	Coated class 3C3
Ambient temperature, VLT 6002-6005 200-240 V, 6002-6011 380-460 V, 6002-6011 525-600 V Bookstyle, IP 20	Max. 45°C (24-hour average max. 40°C)
Ambient temperature, VLT 6006-6062 200-240 V, 6016-6602 380-460 V, 6016-6402 525-600 V IP 00, IP 20	Max. 40°C (24-hour average max. 35°C)
Ambient temperature, VLT 6002-6062 200-240 V, 6002-6602 380-460 V, VLT 6102-6402, 525-600 V, IP 54	Max. 40°C (24-hour average max. 35°C)
Min. ambient temperature in full operation	0°C
Min. ambient temperature at reduced performance	-10°C
Temperature during storage/transport	-25 - +65/70°C
Max. altitude above sea level	1000 m
EMC standards applied, Emission	EN 61000-6-3/4, EN 61800-3, EN 55011, EN 55014
EMC standards applied, Immunity	EN 50082-2, EN 61000-4-2, IEC 1000-4-3, EN 61000-4-4, EN 61000-4-5, ENV 50204, EN 61000-4-6, VDE 0160/1990.12

Installation

**NB!:**

VLT 6002-6072, 525-600 V units do not comply with EMC, Low Voltage or PELV directives.

VLT 6000 HVAC protection

- Electronic motor thermal protection against overload.
- Temperature monitoring of heat-sink ensures that the frequency converter cuts out if the temperature reaches 90°C for IP00, IP20 and NEMA 1. For IP54, the cut-out temperature is 80°C. An overtemperature can only be reset when the temperature of the heat-sink has fallen below 60°C.

For the units mentioned below, the limits are as follows:

- VLT 6152, 380-460 V, cuts out at 75° C and can be reset if the temperature is below 60 °C.
- VLT 6172, 380-460 V, cuts out at 80° C and can be reset if the temperature has fallen below 60° C.
- VLT 6222, 380-460 V, cuts out at 95° C and can be reset if the temperature has fallen below 65° C.
- VLT 6272, 380-460 V, cuts out at 95° C and can be reset if the temperature has fallen below 65° C.
- VLT 6352, 380-460 V, cuts out at 105° C and can be reset if the temperature has fallen below 75° C.
- VLT 6402-6602, 380-460 V cuts out at 85° C and can be reset if the temperature has fallen below 60° C
- VLT 6102-6152, 525-600 V, cuts out at 75° C and can be reset if the temperature has fallen below 60° C.
- VLT 6172, 525-600 V, cuts out at 80° C and can be reset if the temperature has fallen below 60° C.
- VLT 6222-6402, 525-600 V, cuts out at 100° C and can be reset if the temperature has fallen below 70° C.

- The frequency converter is protected against short-circuiting on motor terminals U, V, W.
- The frequency converter is protected against earth fault on motor terminals U, V, W.
- Monitoring of the intermediate circuit voltage ensures that the frequency converter cuts out if the intermediate circuit voltage gets too high or too low.
- If a motor phase is missing, the frequency converter cuts out.
- If there is a mains fault, the frequency converter is able to carry out a controlled deceleration.
- If a mains phase is missing, the frequency converter will cut out or autoderate when a load is placed on the motor.

■ Technical data, mains supply 3 x 200-240 V

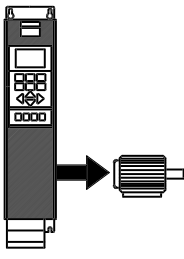
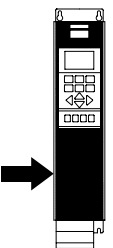
According to international requirements	VLT type	6002	6003	6004	6005	6006	6008	6011	
	Output current ⁴⁾								
	$I_{VLT,N}$ [A]	6.6	7.5	10.6	12.5	16.7	24.2	30.8	
	$I_{VLT,MAX}$ (60 s) [A]	7.3	8.3	11.7	13.8	18.4	26.6	33.9	
	Output power (240 V)								
	$S_{VLT,N}$ [kVA]	2.7	3.1	4.4	5.2	6.9	10.1	12.8	
Typical shaft output	$P_{VLT,N}$ [kW]	1.1	1.5	2.2	3.0	4.0	5.5	7.5	
Typical shaft output	$P_{VLT,N}$ [HP]	1.5	2	3	4	5	7.5	10	
Max. cable cross-section to motor and DC-bus	[mm ²]/[AWG]	4/10	4/10	4/10	4/10	10/8	16/6	16/6	
	Max. input current (200 V) (RMS) $I_{L,N}$ [A]	6.0	7.0	10.0	12.0	16.0	23.0	30.0	
	Max. cable cross-section power [mm ²]/[AWG] ²⁾	4/10	4/10	4/10	4/10	4/10	16/6	16/6	
	Max. pre-fuses [-]/UL ¹⁾ [A]	16/10	16/15	25/20	25/25	35/30	50	60	
	Mains contactor [Danfoss type]	CI 6	CI 6	CI 6	CI 6	CI 6	CI 9	CI 16	
	Efficiency ³⁾	0.95	0.95	0.95	0.95	0.95	0.95	0.95	
	Weight IP 20 [kg]	7	7	9	9	23	23	23	
	Weight IP 54 [kg]	11.5	11.5	13.5	13.5	35	35	38	
	Power loss at max. load. [W]	Total	76	95	126	172	194	426	545
	Enclosure	VLT type	IP 20 / IP 54						

1. For type of fuse, see section *Fuses*.
2. American Wire Gauge.
3. Measured using 30 m screened motor cables at rated load and rated frequency.
4. Current ratings fulfill UL requirements for 208-240 V.

■ Technical data, mains supply 3 x 200-240 V

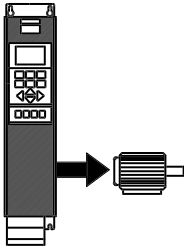
According to international requirements		VLT type	6016	6022	6027	6032	6042	6052	6062
	Output current ⁴⁾	$I_{VLT,N}$ [A] (200-230 V)	46.2	59.4	74.8	88.0	115	143	170
		$I_{VLT,MAX}$ (60 s) [A] (200-230 V)	50.6	65.3	82.3	96.8	127	158	187
	Output power	$I_{VLT,N}$ [A] (240 V)	46.0	59.4	74.8	88.0	104	130	154
		$I_{VLT,MAX}$ (60 s) [A] (240 V)	50.6	65.3	82.3	96.8	115	143	170
Typical shaft output	$S_{VLT,N}$ [kVA] (240 V)	19.1	24.7	31.1	36.6	43.2	54	64	
	$P_{VLT,N}$ [kW]	11	15	18.5	22	30	37	45	
Typical shaft output	$P_{VLT,N}$ [HP]	15	20	25	30	40	50	60	
Max. cable cross-section to motor and DC-bus [mm ²]/[AWG] ^{2) 5)}	Copper	16/6	35/2	35/2	50/0	70/1/0	95/3/0	120/4/0	
	Aluminium ⁶⁾	16/6	35/2	35/2	50/0	95/3/0 ⁵⁾	90/250	120/300	
Min. cable cross-section to motor and DC-bus [mm ²]/[AWG] ²⁾		10/8	10/8	10/8	16/6	10/8	10/8	10/8	
Max. input current (200 V) (RMS) $I_{L,N}$ [A]		46.0	59.2	74.8	88.0	101.3	126.6	149.9	
Max. cable cross-section power [mm ²]/[AWG] ^{2) 5)}	Copper	16/6	35/2	35/2	50/0	70/1/0	95/3/0	120/4/0	
	Aluminium ⁶⁾	16/6	35/2	35/2	50/0	95/3/0 ⁵⁾	90/250	120/300	
Max. pre-fuses	[-]/UL ¹⁾ [A]	60	80	125	125	150	200	250	
Mains contactor	[Danfoss type]	CI 32	CI 32	CI 37	CI 61	CI 85	CI 85	CI 141	
	[AC value]	AC-1	AC-1	AC-1	AC-1				
Efficiency ³⁾		0.95	0.95	0.95	0.95	0.95	0.95	0.95	
Weight IP 00	[kg]	-	-	-	-	90	90	90	
Weight IP 20/NEMA 1	[kg]	23	30	30	48	101	101	101	
Weight IP 54	[kg]	38	49	50	55	104	104	104	
Power loss at max. load.	[W]	545	783	1042	1243	1089	1361	1613	
Enclosure		IP 00/IP 20/NEMA 1/IP 54							

1. For type of fuse, see section *Fuses*.
2. American Wire Gauge.
3. Measured using 30 m screened motor cables at rated load and rated frequency.
4. Current ratings fulfill UL requirements for 208-240 V.
5. Connection stud 1 x M8 / 2 x M8.
6. Aluminium cables with cross section above 35 mm² must be connected by use of an Al-Cu connector.

■ Technical data, mains supply 3 x 380-460 V

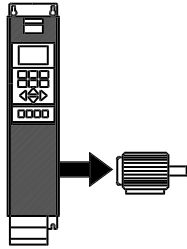
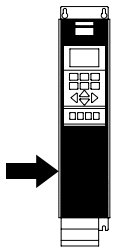
According to international requirements		VLT type	6002	6003	6004	6005	6006	6008	6011
	Output current	$I_{VLT,N}$ [A] (380-440 V)	3.0	4.1	5.6	7.2	10.0	13.0	16.0
		$I_{VLT,MAX}$ (60 s) [A] (380-440 V)	3.3	4.5	6.2	7.9	11.0	14.3	17.6
		$I_{VLT,N}$ [A] (441-460 V)	3.0	3.4	4.8	6.3	8.2	11.0	14.0
		$I_{VLT,MAX}$ (60 s) [A] (441-460 V)	3.3	3.7	5.3	6.9	9.0	12.1	15.4
	Output power	$S_{VLT,N}$ [kVA] (400 V)	2.2	2.9	4.0	5.2	7.2	9.3	11.5
		$S_{VLT,N}$ [kVA] (460 V)	2.4	2.7	3.8	5.0	6.5	8.8	11.2
	Typical shaft output	$P_{VLT,N}$ [kW]	1.1	1.5	2.2	3.0	4.0	5.5	7.5
	Typical shaft output	$P_{VLT,N}$ [HP]	1.5	2	3	-	5	7.5	10
	Max. cable cross-section to motor	[mm ²]/[AWG] ^{2) 4)}	4/10	4/10	4/10	4/10	4/10	4/10	4/10
	Max. input current (RMS)	$I_{L,N}$ [A] (380 V)	2.8	3.8	5.3	7.0	9.1	12.2	15.0
		$I_{L,N}$ [A] (460 V)	2.5	3.4	4.8	6.0	8.3	10.6	14.0
	Max. cable cross-section power	[mm ²]/[AWG] ^{2) 4)}	4/10	4/10	4/10	4/10	4/10	4/10	4/10
	Max. pre-fuses	[-]/UL ¹⁾ [A]	16/6	16/10	16/10	16/15	25/20	25/25	35/30
	Mains contactor	[Danfoss type]	CI 6	CI 6	CI 6	CI 6	CI 6	CI 6	CI 6
	Efficiency ³⁾		0.96	0.96	0.96	0.96	0.96	0.96	0.96
	Weight IP 20	[kg]	8	8	8.5	8.5	10.5	10.5	10.5
	Weight IP 54	[kg]	11.5	11.5	12	12	14	14	14
	Power loss at max. load. [W]	Total	67	92	110	139	198	250	295
	Enclosure	VLT type	IP 20/IP 54						

1. For type of fuse, see section *Fuses*.
 2. American Wire Gauge.
 3. Measured using 30 m screened motor cables at rated load and rated frequency.
 4. Max. cable cross section is the maximum possible cable cross section that can be fitted on the terminals.
- Always comply with national and local regulations on min. cable cross-section.

■ Technical data, mains supply 3 x 380-460 V

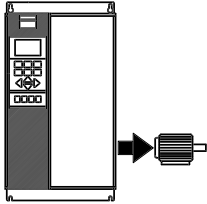
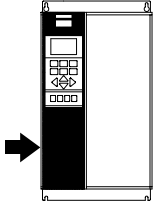
According to international requirements		VLT type	6016	6022	6027	6032	6042	
	Output current	$I_{VLT,N}$ [A] (380-440 V)	24.0	32.0	37.5	44.0	61.0	
		$I_{VLT,MAX}$ (60 s) [A] (380-440 V)	26.4	35.2	41.3	48.4	67.1	
	Output power	$I_{VLT,N}$ [A] (441-460 V)	21.0	27.0	34.0	40.0	52.0	
		$I_{VLT,MAX}$ (60 s) [A] (441-460 V)	23.1	29.7	37.4	44.0	57.2	
		$S_{VLT,N}$ [kVA] (400 V)	17.3	23.0	27.0	31.6	43.8	
		$S_{VLT,N}$ [kVA] (460 V)	16.7	21.5	27.1	31.9	41.4	
Typical shaft output	$P_{VLT,N}$ [kW]	11	15	18.5	22	30		
Typical shaft output	$P_{VLT,N}$ [HP]	15	20	25	30	40		
Max. cable cross-section to motor and DC-bus, IP 20	[mm ²]/[AWG] ^{2) 4)}		16/6	16/6	16/6	35/2	35/2	
Max. cable cross-section to motor and DC-bus, IP 54			16/6	16/6	16/6	16/6	35/2	
Min. cable cross-section to motor and DC-bus	[mm ²]/[AWG] ^{2) 4)}	10/8	10/8	10/8	10/8	10/8		
	Max. input current (RMS)	$I_{L,N}$ [A] (380 V)	24.0	32.0	37.5	44.0	60.0	
		$I_{L,N}$ [A] (460 V)	21.0	27.6	34.0	41.0	53.0	
	Max. cable cross-section power, IP 20	[mm ²]/[AWG] ^{2) 4)}		16/6	16/6	16/6	35/2	35/2
	Max. cable cross-section power, IP 54			16/6	16/6	16/6	16/6	35/2
	Max. pre-fuses	[-/UL ¹⁾] [A]	63/40	63/40	63/50	63/60	80/80	
	Mains contactor	[Danfoss type]	CI 9	CI 16	CI 16	CI 32	CI 32	
	Efficiency at rated frequency		0.96	0.96	0.96	0.96	0.96	
	Weight IP 20	[kg]	21	21	22	27	28	
	Weight IP 54	[kg]	41	41	42	42	54	
	Power loss at max. load.	[W]	419	559	655	768	1065	
Enclosure		IP 20/ IP 54						

1. For type of fuse, see section *Fuses*.

2. American Wire Gauge.

3. Measured using 30 m screened motor cables at rated load and rated frequency.

4. Min. cable cross-section is the smallest cable cross-section allowed to be fitted on the terminals. Max. cable cross section is the maximum possible cable cross section that can be fitted on the terminals.

Always comply with national and local regulations on min. cable cross-section.

■ Technical data, mains supply 3 x 380-460 V

According to international requirements		VLT type	6052	6062	6072	6102	6122	
Output current	$I_{VLT,N}$ [A] (380-440 V)		73.0	90.0	106	147	177	
	$I_{VLT,MAX}$ (60 s) [A] (380-440 V)		80.3	99.0	117	162	195	
	$I_{VLT,N}$ [A] (441-460 V)		65.0	77.0	106	130	160	
	$I_{VLT,MAX}$ (60 s) [A] (441-460 V)		71.5	84.7	117	143	176	
Output power	$S_{VLT,N}$ [kVA] (400 V)		52.5	64.7	73.4	102	123	
	$S_{VLT,N}$ [kVA] (460 V)		51.8	61.3	84.5	104	127	
Typical shaft output	$P_{VLT,N}$ [kW]		37	45	55	75	90	
Typical shaft output	$P_{VLT,N}$ [HP]		50	60	75	100	125	
Max. cable cross-section to motor and DC-bus, IP 20	$[mm^2]/[AWG]^{2) 4) 6)}$		35/2	50/0	50/0	120 / 250	120 / 250	
						mcm ⁵⁾	mcm ⁵⁾	
Max. cable cross-section to motor and DC-bus, IP 54	$[mm^2]/[AWG]^{2) 4) 6)}$		35/2	50/0	50/0	150 / 300	150 / 300	
						mcm ⁵⁾	mcm ⁵⁾	
Min. cable cross-section to motor and DC-bus	$[mm^2]/[AWG]^{2) 4)}$		10/8	16/6	16/6	25/4	25/4	
Max. input current (RMS)	$I_{L,N}$ [A] (380 V)		72.0	89.0	104	145	174	
	$I_{L,N}$ [A] (460 V)		64.0	77.0	104	128	158	
Max. cable cross-section power, IP 20	$[mm^2]/[AWG]^{2) 4) 6)}$		35/2	50/0	50/0	120 / 250	120 / 250	
						mcm	mcm	
Max. cable cross-section power, IP 54	$[mm^2]/[AWG]^{2) 4) 6)}$		35/2	50/0	50/0	150 / 300	150 / 300	
						mcm	mcm	
Max. pre-fuses	$[-]/[UL^1)$ [A]		100/100	125/125	150/150	225/225	250/250	
Mains contactor	[Danfoss type]		CI 37	CI 61	CI 85	CI 85	CI 141	
Efficiency at rated frequency			0.96	0.96	0.96	0.98	0.98	
Weight IP 20	[kg]		41	42	43	54	54	
Weight IP 54	[kg]		56	56	60	77	77	
Power loss at max. load.	[W]		1275	1571	1322	1467	1766	
Enclosure							IP 20/IP 54	

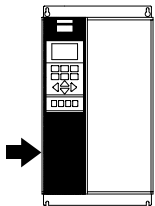
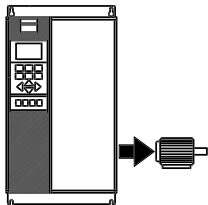

1. For type of fuse, see section *Fuses*.
2. American Wire Gauge.
3. Measured using 30 m screened motor cables at rated load and rated frequency.
4. Min. cable cross-section is the smallest cable cross-section allowed to be fitted on the terminals.
Max. cable cross section is the maximum possible cable cross section that can be fitted on the terminals.
Always comply with national and local regulations on min. cable cross-section.
5. DC connection 95 mm²/AWG 3/0.
6. Aluminium cables with cross-section above 35 mm² must be connected by use of an Al-Cu connector.

■ Technical data, mains supply 3 x 380-460 V

According to international requirements		VLT type	6152	6172	6222	6272	6352
Output current	$I_{VLT,N}$ [A] (380-440 V)		212	260	315	395	480
	$I_{VLT,MAX}$ (60 s) [A] (380-440 V)		233	286	347	435	528
	$I_{VLT,N}$ [A] (441-460 V)		190	240	302	361	443
	$I_{VLT,MAX}$ (60 s) [A] (441-460 V)		209	264	332	397	487
Output power	$S_{VLT,N}$ [kVA] (400 V)		147	180	218	274	333
	$S_{VLT,N}$ [kVA] (460 V)		151	191	241	288	353
Typical shaft output (380-440 V) $P_{VLT,N}$ [kW]			110	132	160	200	250
Typical shaft output (441-460 V) $P_{VLT,N}$ [HP]			150	200	250	300	350
Max. cable cross-section to motor and DC-bus [mm ²] 2) 4) 5)			2x70	2x70	2x185	2x185	2x185
Max. cable cross-section to motor and DC-bus [AWG] 2) 4) 5)			2x2/0	2x2/0	2x350	2x350	2x350
Min. cable cross-section to motor and DC-bus [mm ² /AWG] 2) 4) 5)			35/2	35/2	35/2	35/2	35/2
Max. input current (RMS)	$I_{L,N}$ [A] (380 V)		208	256	317	385	467
	$I_{L,N}$ [A] (460 V)		185	236	304	356	431
Max. cable cross-section to power [mm ²] 4) 5)			2x70	2x70	2x185	2x185	2x185
Max. cable cross-section to power [AWG] 2) 4) 5)			2x2/0	2x2/0	2x350	2x350	2x350
Max. pre-fuses [-]/UL 1) [A]			300/300	350/350	450/400	500/500	630/600
Mains contactor	[Danfoss type]		CI 141	CI 250EL	CI 250EL	CI 300EL	CI 300EL
Weight IP 00	[kg]		82	91	112	123	138
Weight IP 20	[kg]		96	104	125	136	151
Weight IP 54	[kg]		96	104	125	136	151
Efficiency at rated frequency			0.98				
Power loss at max. load.	[W]		2619	3309	4163	4977	6107
Enclosure			IP 00/IP 21/NEMA 1/IP 54				

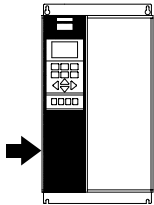
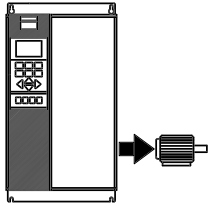

1. For type of fuse, see section *Fuses*.
2. American Wire Gauge.
3. Measured using 30 m screened motor cables at rated load and rated frequency.
4. Min. cable cross-section is the smallest cable cross-section allowed to be fitted on the terminals. Max. cable cross section is the maximum possible cable cross section that can be fitted on the terminals.
Always comply with national and local regulations on min. cable cross-section.
5. Connection bolt 1 x M10 / 2 x M10 (mains and motor), connection bolt 1 x M8 / 2 x M8 (DC-bus).

■ Technical data, mains supply 3 x 380-460 V

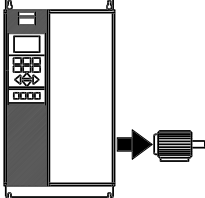
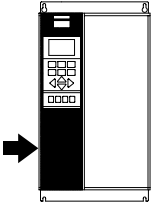
According to international requirements	VLT type	6402	6502	6552	6602	
	Output current	$I_{VLT,N}$ [A] (380-440 V)	600	658	745	800
		$I_{VLT,MAX}$ (60 s) [A] (380-440 V)	660	724	820	880
		$I_{VLT,N}$ [A] (441-460 V)	540	590	678	730
		$I_{VLT,MAX}$ (60 s) [A] (441-460 V)	594	649	746	803
	Output power	$S_{VLT,N}$ [kVA] (400 V)	416	456	516	554
		$S_{VLT,N}$ [kVA] (460 V)	430	470	540	582
	Typical shaft output (380-440 V) $P_{VLT,N}$ [kW]		315	355	400	450
	Typical shaft output (441-460 V) $P_{VLT,N}$ [HP]		450	500	550/600	600
	Max. cable cross-section to motor and DC-bus		4 x 240	4 x 240	4 x 240	4 x 240
	$[mm^2]$ ^{4) 5)}					
	Max. cable cross-section to motor and DC-bus		4 x 500 mcm	4 x 500 mcm	4 x 500 mcm	4 x 500 mcm
	$[AWG]$ ^{2) 4) 5)}					
	Max. input current (RMS)	$I_{L,MAX}$ [A] (380 V)	584	648	734	787
		$I_{L,MAX}$ [A] (460 V)	526	581	668	718
Max. cable cross-section to power	$[mm^2]$ ^{4) 5)}	4 x 240	4 x 240	4 x 240	4 x 240	
Max. cable cross-section to power	$[AWG]$ ^{2) 4) 5)}	4 x 500 mcm	4 x 500 mcm	4 x 500 mcm	4 x 500 mcm	
Max. pre-fuses (mains)	$[-]/UL$ $[A]$ ¹⁾	700/700	900/900	900/900	900/900	
Efficiency ³⁾		0.98	0.98	0.98	0.98	
Mains contactor	[Danfoss type] CI 300EL	-	-	-	-	
Weight IP 00	[kg]	221	234	236	277	
Weight IP 20	[kg]	263	270	272	313	
Weight IP 54	[kg]	263	270	272	313	
Power loss at max. load	[W]	7630	7701	8879	9428	
Enclosure		IP 00 / IP 21/NEMA 1 / IP 54				

1. For type of fuse, see section *Fuses*.
2. American Wire Gauge.
3. Measured using 30 m screened motor cables at rated load and rated frequency.
4. Always comply with national and local regulations on min. cable cross-section. Max. cable cross section is the maximum possible cable cross section that can be fitted on the terminals.
5. Connection bolt power supply, motor and load sharing: M10 compression (lug), 2 x M8 (box lug)

■ Technical data, mains supply 3 x 525-600 V

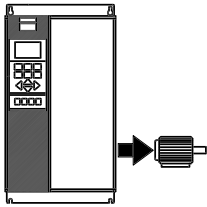
According to international requirements		VLT type	6002	6003	6004	6005	6006	6008	6011	
	Output current $I_{VLT,N}$ [A] (550 V)		2.6	2.9	4.1	5.2	6.4	9.5	11.5	
	$I_{VLT,MAX}$ (60 s) [A] (550V)		2.9	3.2	4.5	5.7	7.0	10.5	12.7	
	$I_{VLT,N}$ [A] (575 V)		2.4	2.7	3.9	4.9	6.1	9.0	11.0	
	$I_{VLT,MAX}$ (60 s) [A] (575 V)		2.6	3.0	4.3	5.4	6.7	9.9	12.1	
	Output S $S_{VLT,N}$ [kVA] (550 V)		2.5	2.8	3.9	5.0	6.1	9.0	11.0	
	$S_{VLT,N}$ [kVA] (575 V)		2.4	2.7	3.9	4.9	6.1	9.0	11.0	
	Typical shaft output $P_{VLT,N}$ [kW]		1.1	1.5	2.2	3	4	5.5	7.5	
	Typical shaft output $P_{VLT,N}$ [HP]		1.5	2	3	4	5	7.5	10	
	Max. copper cable cross-section to motor and loadsharing									
		[mm ²]	4	4	4	4	4	4	4	4
	[AWG] ²⁾	10	10	10	10	10	10	10	10	
Rated Input	$I_{VLT,N}$ [A] (550 V)	2.5	2.8	4.0	5.1	6.2	9.2	11.2		
Current	$I_{VLT,N}$ [A] (600 V)	2.2	2.5	3.6	4.6	5.7	8.4	10.3		
Max.copper cable cross-section, power										
	[mm ²]	4	4	4	4	4	4	4	4	
	[AWG] ²⁾	10	10	10	10	10	10	10	10	
Max. prefuses (mains) ¹⁾ [-]/UL [A]		3	4	5	6	8	10	15		
Efficiency		0.96								
Weight IP20	[kg]	10.5	10.5	10.5	10.5	10.5	10.5	10.5	10.5	
/ NEMA 1	[lbs]	23	23	23	23	23	23	23	23	
Estimated power loss at max. load (550 V) [W]		65	73	103	131	161	238	288		
Estimated power loss at max. load (600V) [W]		63	71	102	129	160	236	288		
Enclosure		IP 20/NEMA 1								

1. For type of fuse, see section *Fuses*.
2. American Wire Gauge (AWG).
3. Min. cable cross-section is the smallest cable cross-section allowed to be fitted into the terminals to comply with IP20. Always comply with national and local regulations on min. cable cross-section.

■ Technical data, mains supply 3 x 525-600 V

According to international requirements		6016	6022	6027	6032	6042	6052	6062	6072
Output current $I_{VLT,N}$ [A] (550 V)		18	23	28	34	43	54	65	81
$I_{VLT,MAX}$ (60 s) [A] (550V)		20	25	31	37	47	59	72	89
$I_{VLT,N}$ [A] (575 V)		17	22	27	32	41	52	62	77
$I_{VLT,MAX}$ (60 s) [A] (575 V)		19	24	30	35	45	57	68	85
Output	$S_{VLT,N}$ [kVA] (550 V)	17	22	27	32	41	51	62	77
	$S_{VLT,N}$ [kVA] (575 V)	17	22	27	32	41	52	62	77
Typical shaft output $P_{VLT,N}$ [kW]		11	15	18.5	22	30	37	45	55
Typical shaft output $P_{VLT,N}$ [HP]		15	20	25	30	40	50	60	75
Max. copper cable									
cross-section to motor	[mm ²]	16	16	16	35	35	50	50	50
and loadsharing ⁴⁾	[AWG] ²⁾	6	6	6	2	2	1/0	1/0	1/0
Min. cable									
cross-section to motor	[mm ²]	0.5	0.5	0.5	10	10	16	16	16
and loadsharing ³⁾	[AWG] ²⁾	20	20	20	8	8	6	6	6
Rated Input Current									
$I_{VLT,N}$ [A] (550 V)		18	22	27	33	42	53	63	79
$I_{VLT,N}$ [A] (600 V)		16	21	25	30	38	49	38	72
Max copper cable	[mm ²]	16	16	16	35	35	50	50	50
cross section, power ⁴⁾	[AWG] ²⁾	6	6	6	2	2	1/0	1/0	1/0
Max. prefuses (mains) ¹⁾ [-]/UL [A]		20	30	35	45	60	75	90	100
Efficiency		0.96							
Weight IP20 / NEMA 1	[kg]	23	23	23	30	30	48	48	48
	[lbs]	51	51	51	66	66	106	106	106
Estimated power loss at max. load (550 V) [W]		451	576	702	852	1077	1353	1628	2029
Estimated power loss at max. load (600 V) [W]		446	576	707	838	1074	1362	1624	2016
Enclosure		NEMA 1							

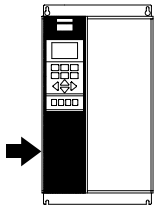
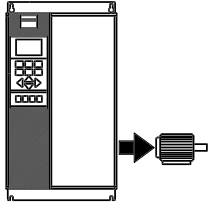

1. For type of fuse, see section *Fuses*.
2. American Wire Gauge (AWG).
3. Min. cable cross-section is the smallest cable cross-section allowed to be fitted into the terminals to comply with IP20. Always comply with national and local regulations on min. cable cross-section.
4. Aluminium cables with cross-section above 35 mm² must be connected by use of an Al-Cu connector.

■ Mains supply 3 x 525-600 V

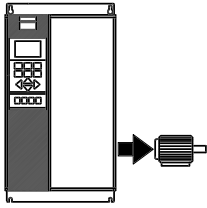
According to international requirements		VLT type	6102	6122
	Output current	$I_{VLT,N}$ [A] (525-550 V)	113	137
		$I_{VLT,MAX}$ (60 s) [A] (525-550 V)	124	151
	Output	$I_{VLT,N}$ [A] (551-600 V)	108	131
		$I_{VLT,MAX}$ (60 s) [A] (551-600 V)	119	144
Typical shaft output	$S_{VLT,N}$ [kVA] (550 V)	108	131	
	$S_{VLT,N}$ [kVA] (575 V)	108	130	
Max. cable cross-section to motor	[kW] (550 V)	75	90	
	[HP] (575 V)	100	125	
Max. cable cross-section to loadsharing and brake	[mm ²] ^{4,5}	2 x 70		
	[AWG] ^{2,4,5}	2 x 2/0		
Rated input current	$I_{L,N}$ [A] (550 V)	110	130	
	$I_{L,N}$ [A] (575 V)	106	124	
	$I_{L,N}$ [A] (690 V)	109	128	
Max. cable cross-section power supply	[mm ²] ^{4,5}	2 x 70		
	[AWG] ^{2,4,5}	2 x 2/0		
Min. cable cross-section to motor and power supply	[mm ²] ^{4,5}	35		
	[AWG] ^{2,4,5}	2		
Min. cable cross-section to brake and loadsharing	[mm ²] ^{4,5}	10		
	[AWG] ^{2,4,5}	8		
Max. pre-fuses (mains) [-]/UL	[A] ¹	200	250	
Efficiency ³			0.98	
Power loss [W]		2156	2532	
Weight	IP 00 [kg]		82	
	IP 21/Nema1 [kg]		96	
	IP 54/Nema12 [kg]		96	
Enclosure		IP 00, IP 21/Nema 1 and IP 54/Nema12		

1. For type of fuse see section *Fuses*
2. American Wire Gauge.
3. Measured using 30 m screened motor cables at rated load and rated frequency.
4. Max. cable cross-section is the maximum possible cable cross-section allowed to be fitted on the terminals. Min. cable cross-section is the minimum allowed cross-section. Always comply with national and local regulations on min. cable cross-section.
5. Connection bolt 1 x M10 / 2 x M10 (mains and motor), connection bolt 1 x M8 / 2 x M8 (DC-bus).

■ Mains supply 3 x 525-600 V

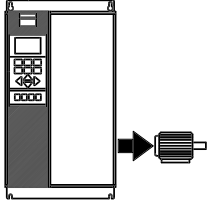
According to international requirements		VLT type	6152	6172	6222	6272	6352	6402
	Output current	$I_{VLT,N}$ [A] (525-550 V)	162	201	253	303	360	418
		$I_{VLT, MAX}$ (60 s) [A] (525-550 V)	178	221	278	333	396	460
		$I_{VLT,N}$ [A] (551-600 V)	155	192	242	290	344	400
		$I_{VLT, MAX}$ (60 s) [A] (551-600 V)	171	211	266	319	378	440
	Output	$S_{VLT,N}$ [kVA] (550 V)	154	191	241	289	343	398
		$S_{VLT,N}$ [kVA] (575 V)	154	191	241	289	343	398
Typical shaft output	[kW] (550 V)	110	132	160	200	250	315	
	[HP] (575 V)	150	200	250	300	350	400	
Max. cable cross-section to motor	[mm ²] ^{4,5}	2 x 70				2 x 185		
	[AWG] ^{2,4,5}	2 x 2/0				2 x 350 mcm		
Max. cable cross-section to loadsharing and brake	[mm ²] ^{4,5}	2 x 70				2 x 185		
	[AWG] ^{2,4,5}	2 x 2/0				2 x 350 mcm		
Rated input current	$I_{L,N}$ [A] (550 V)	158	198	245	299	355	408	
	$I_{L,N}$ [A] (575 V)	151	189	234	286	339	390	
	$I_{L,N}$ [A] (690 V)	155	197	240	296	352	400	
Max. cable cross-section power supply	[mm ²] ^{4,5}	2 x 70				2 x 185		
	[AWG] ^{2,4,5}	2 x 2/0				2 x 350 mcm		
Min. cable cross-section to motor and power supply	[mm ²] ^{4,5}				35			
	[AWG] ^{2,4,5}				2			
Min. cable cross-section to brake and loadsharing	[mm ²] ^{4,5}				10			
	[AWG] ^{2,4,5}				8			
Max. pre-fuses (mains)	[A] ¹	315	350	350	400	500	550	
[-]/UL								
Efficiency ³					0,98			
Power loss [W]		2963	3430	4051	4867	5493	5852	
Weight	IP 00 [kg]	82	91	112	123	138	151	
Weight	IP 21/Nema1 [kg]	96	104	125	136	151	165	
Weight	IP 54/Nema12 [kg]	96	104	125	136	151	165	
Enclosure		IP 00, IP 21/Nema 1 and IP 54/Nema12						

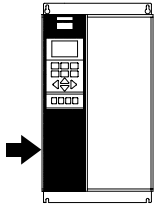

1. For type of fuse see section *Fuses*
2. American Wire Gauge.
3. Measured using 30 m screened motor cables at rated load and rated frequency.
4. Max. cable cross-section is the maximum possible cable cross-section allowed to be fitted on the terminals. Min. cable cross-section is the minimum allowed cross-section. Always comply with national and local regulations on min. cable cross-section.
5. Connection bolt 1 x M10 / 2 x M10 (mains and motor), connection bolt 1 x M8 / 2 x M8 (DC-bus).

■ Fuses
UL compliance

To comply with UL/cUL approvals, pre-fuses according to the table below must be used.

200-240 V

VLT	Bussmann	SIBA	Littel fuse	Ferraz-Shawmut
6002	KTN-R10	5017906-010	KLN-R10	ATM-R10 or A2K-10R
6003	KTN-R15	5017906-016	KLN-R15	ATM-R15 or A2K-15R
6004	KTN-R20	5017906-020	KLN-R20	ATM-R20 or A2K-20R
6005	KTN-R25	5017906-025	KLN-R25	ATM-R25 or A2K-25R
6006	KTN-R30	5017906-032	KLN-R30	ATM-R30 or A2K-30R
6008	KTN-R50	5012406-050	KLN-R50	A2K-50R
6011, 6016	KTN-R60	5014006-063	KLN-R60	A2K-60R
6022	KTN-R80	5014006-080	KLN-R80	A2K-80R
6027, 6032	KTN-R125	2028220-125	KLN-R125	A2K-125R
6042	FWX-150	2028220-150	L25S-150	A25X-150
6052	FWX-200	2028220-200	L25S-200	A25X-200
6062	FWX-250	2028220-250	L25S-250	A25X-250

380-460 V

	Bussmann	SIBA	Littel fuse	Ferraz-Shawmut
6002	KTS-R6	5017906-006	KLS-R6	ATM-R6 or A6K-6R
6003, 6004	KTS-R10	5017906-010	KLS-R10	ATM-R10 or A6K-10R
6005	KTS-R15	5017906-016	KLS-R16	ATM-R16 or A6K-16R
6006	KTS-R20	5017906-020	KLS-R20	ATM-R20 or A6K-20R
6008	KTS-R25	5017906-025	KLS-R25	ATM-R25 or A6K-25R
6011	KTS-R30	5012406-032	KLS-R30	ATM-R30 or A6K-30R
6016, 6022	KTS-R40	5014006-040	KLS-R40	A6K-40R
6027	KTS-R50	5014006-050	KLS-R50	A6K-50R
6032	KTS-R60	5014006-063	KLS-R60	A6K-60R
6042	KTS-R80	2028220-100	KLS-R80	A6K-80R
6052	KTS-R100	2028220-125	KLS-R100	A6K-100R
6062	KTS-R125	2028220-125	KLS-R125	A6K-125R
6072	KTS-R150	2028220-160	KLS-R150	A6K-150R
6102	FWH-220	2028220-200	L50S-225	A50-P225
6122	FWH-250	2028220-250	L50S-250	A50-P250
6152*	FWH-300/170M3017	2028220-315	L50S-300	A50-P300
6172*	FWH-350/170M3018	2028220-315	L50S-350	A50-P350
6222*	FWH-400/170M4012	206xx32-400	L50S-400	A50-P400
6272*	FWH-500/170M4014	206xx32-500	L50S-500	A50-P500
6352*	FWH-600/170M4016	206xx32-600	L50S-600	A50-P600
6402	170M4017			
6502	170M6013			
6552	170M6013			
6602	170M6013			

* Circuit Breakers manufactured by General Electric, Cat .No. SKHA36AT0800, with the rating plugs listed below can be used to meet UL requirement.

6152	rating plug No.	SRPK800 A 300
6172	rating plug No.	SRPK800 A 400
6222	rating plug No.	SRPK800 A 400
6272	rating plug No.	SRPK800 A 500
6352	rating plug No.	SRPK800 A 600

525-600 V

	Bussmann	SIBA	Littel fuse	Ferraz-Shawmut
6002	KTS-R3	5017906-004	KLS-R003	A6K-3R
6003	KTS-R4	5017906-004	KLS-R004	A6K-4R
6004	KTS-R5	5017906-005	KLS-R005	A6K-5R
6005	KTS-R6	5017906-006	KLS-R006	A6K-6R
6006	KTS-R8	5017906-008	KLS-R008	A6K-8R
6008	KTS-R10	5017906-010	KLS-R010	A6K-10R
6011	KTS-R15	5017906-016	KLS-R015	A6K-15R
6016	KTS-R20	5017906-020	KLS-R020	A6K-20R
6022	KTS-R30	5017906-030	KLS-R030	A6K-30R
6027	KTS-R35	5014006-040	KLS-R035	A6K-35R
6032	KTS-R45	5014006-050	KLS-R045	A6K-45R
6042	KTS-R60	5014006-063	KLS-R060	A6K-60R
6052	KTS-R75	5014006-080	KLS-R075	A6K-80R
6062	KTS-R90	5014006-100	KLS-R090	A6K-90R
6072	KTS-R100	5014006-100	KLS-R100	A6K-100R

525-600 V

	Bussmann	SIBA	FERRAZ-SHAWMUT
6102	170M3015	2061032,2	6.6URD30D08A0200
6122	170M3016	2061032,25	6.6URD30D08A0250
6152	170M3017	2061032,315	6.6URD30D08A0315
6172	170M3018	2061032,35	6.6URD30D08A0350
6222	170M4011	2061032,35	6.6URD30D08A0350
6272	170M4012	2061032,4	6.6URD30D08A0400
6352	170M4014	2061032,5	6.6URD30D08A0500
6402	170M5011	2062032,55	6.6URD32D08A550

Installation

KTS-fuses from Bussmann may substitute KTN for 240 V drives.
 FWH-fuses from Bussmann may substitute FWX for 240 V drives.

KLSR fuses from LITTEL FUSE may substitute KLNLR fuses for 240 V drives.
 L50S fuses from LITTEL FUSE may substitute L25S fuses for 240 V drives.

A6KR fuses from FERRAZ SHAWMUT may substitute A2KR for 240 V drives.
 A50X fuses from FERRAZ SHAWMUT may substitute A25X for 240 V drives.

Non UL compliance

If UL/cUL is not to be complied with, we recommend the above mentioned fuses or:

VLT 6002-6032	200-240 V	type gG
VLT 6042-6062	200-240 V	type gR
VLT 6002-6072	380-460 V	type gG
VLT 6102-6122	380-460 V	type gR
VLT 6152-6352	380-460 V	type gG
VLT 6402-6602	380-460 V	type gR
VLT 6002-6072	525-600 V	type gG

Not following the recommendation may result in damage of the drive in case of malfunction. Fuses must be designed for protection in a circuit capable of supplying a maximum of 100000 A_{rms} (symmetrical), 500 V / 600 V maximum.

■ Mechanical dimensions

All the below listed measurements are in mm.

VLT type	A	B	C	a	b	aa/bb	Type	
Bookstyle IP 20 200 - 240 V								
6002 - 6003	395	90	260	384	70	100	A	
6004 - 6005	395	130	260	384	70	100	A	
Bookstyle IP 20 380 - 460 V								
6002 - 6005	395	90	260	384	70	100	A	
6006 - 6011	395	130	260	384	70	100	A	
IP 00 200 - 240 V								
6042 - 6062	800	370	335	780	270	225	B	
IP 00 380 - 460 V								
6152 - 6172	1046	408	373 ¹⁾	1001	304	225	J	
6222 - 6352	1327	408	373 ¹⁾	1282	304	225	J	
6402 - 6602	1547	585	494 ¹⁾	1502	304	225	J	
IP 20 200 - 240 V								
6002 - 6003	395	220	160	384	200	100	C	
6004 - 6005	395	220	200	384	200	100	C	
6006 - 6011	560	242	260	540	200	200	D	
6016 - 6022	700	242	260	680	200	200	D	
6027 - 6032	800	308	296	780	270	200	D	
6042 - 6062	954	370	335	780	270	225	E	
IP 20 380 - 460 V								
6002 - 6005	395	220	160	384	200	100	C	
6006 - 6011	395	220	200	384	200	100	C	
6016 - 6027	560	242	260	540	200	200	D	
6032 - 6042	700	242	260	680	200	200	D	
6052 - 6072	800	308	296	780	270	200	D	
6102 - 6122	800	370	335	780	330	225	D	
IP 21/NEMA 1 380-460 V								
6152 - 6172	1208	420	373 ¹⁾	1154	304	225	J	
6222 - 6352	1588	420	373 ¹⁾	1535	304	225	J	
6402 - 6602	2000	600	494 ¹⁾	-	-	225	H	
IP 54 200 - 240 V								
6002 - 6003	460	282	195	85	260	258	100	F
6004 - 6005	530	282	195	85	330	258	100	F
6006 - 6011	810	350	280	70	560	326	200	F
6016 - 6032	940	400	280	70	690	375	200	F
6042 - 6062	937	495	421	-	830	374	225	G
IP 54 380 - 460 V								
6002 - 6005	460	282	195	85	260	258	100	F
6006 - 6011	530	282	195	85	330	258	100	F
6016 - 6032	810	350	280	70	560	326	200	F
6042 - 6072	940	400	280	70	690	375	200	F
6102 - 6122	940	400	360	70	690	375	225	F
6152 - 6172	1208	420	373 ¹⁾	-	1154	304	225	J
6222 - 6352	1588	420	373 ¹⁾	-	1535	304	225	J
6402 - 6602	2000	600	494 ¹⁾	-	-	-	225	H

1. With disconnect add 44 mm.

aa: Minimum space above enclosure

bb: Minimum space below enclosure

■ Mechanical dimensions

All the below listed measurements are in mm.

VLT Type	A	B	C	a	b	aa/bb	Type
IP 00 525 - 600 V							
6102 - 6172	1046	408	373 ¹⁾	1001	304	225	J
6222 - 6402	1327	408	373 ¹⁾	1282	304	225	J
IP 20/NEMA 1 525 - 600 V							
6002 - 6011	395	220	200	384	200	100	C
6016 - 6027	560	242	260	540	200	200	D
6032 - 6042	700	242	260	680	200	200	D
6052 - 6072	800	308	296	780	270	200	D
6102 - 6172	1208	420	373 ¹⁾	1154	304	225	J
6222 - 6402	1588	420	373 ¹⁾	1535	304	225	J
IP 54 525 - 600 V							
6102 - 6172	1208	420	373 ¹⁾	1154	304	225	J
6222 - 6402	1588	420	373 ¹⁾	1535	304	225	J

aa: Minimum space above enclosure

bb: Minimum space below enclosure

■ Mechanical dimensions

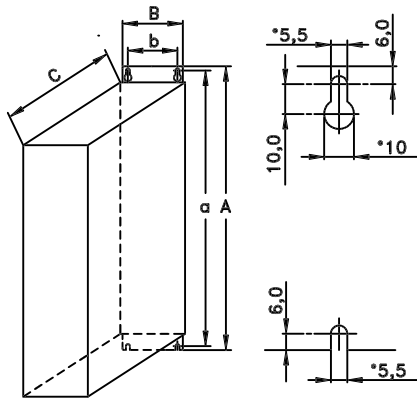

Type A, IP20

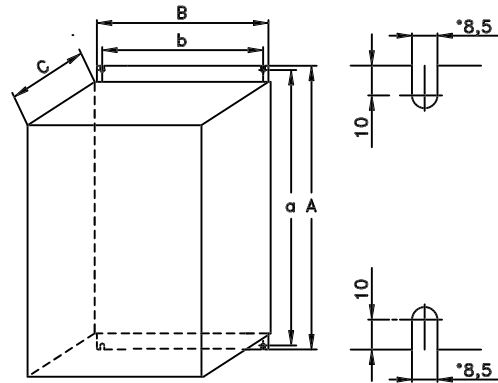

Type D, IP20

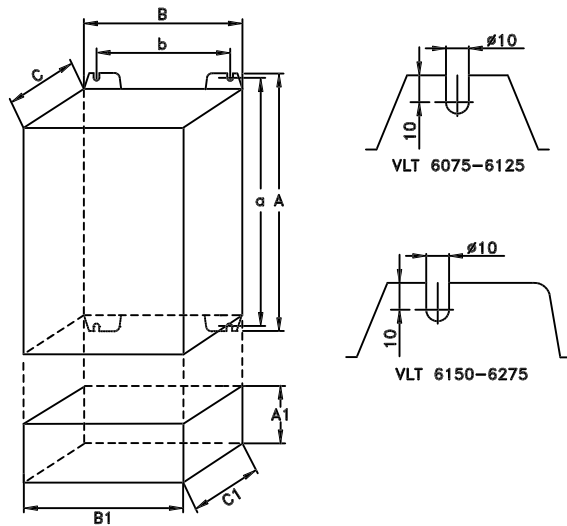

Type B, IP00
With option and enclosure IP20

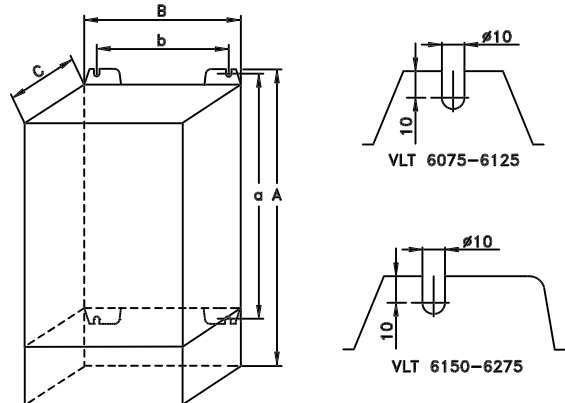

Type E, IP20

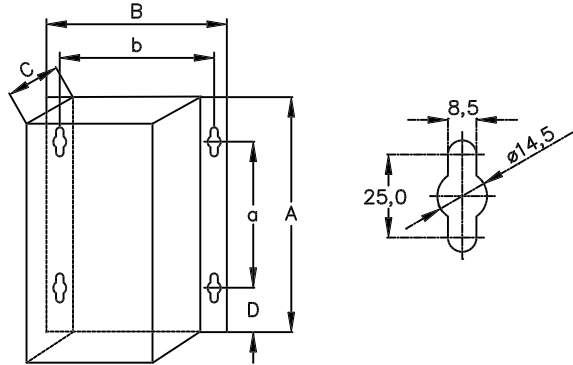

Type F, IP54

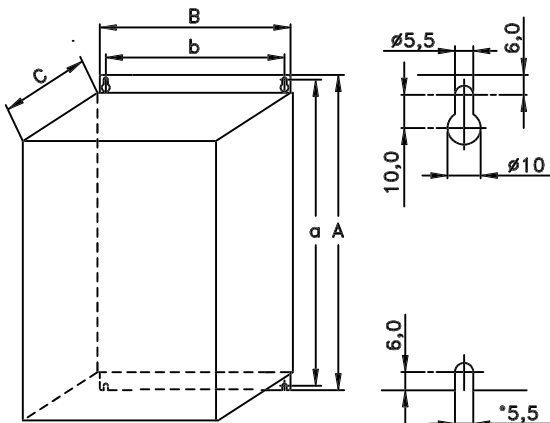

Type C, IP20

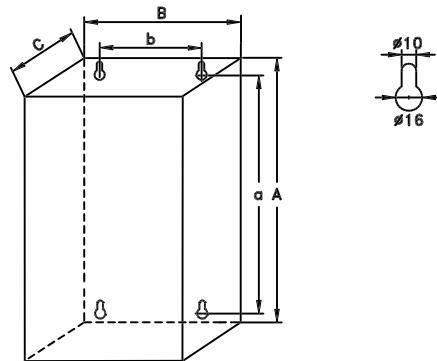

Type G, IP54

■ Mechanical dimensions (cont.)

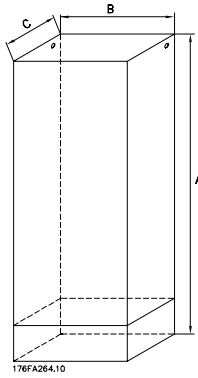

Type H, IP 20, IP 54

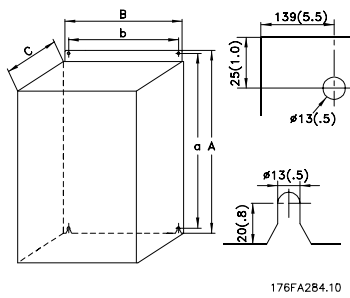

Type I, IP 00

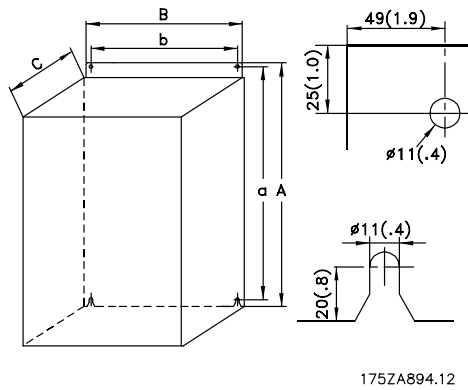

Type J, IP 00, IP 21, IP 54

Installation

■ Index

	Serial communication.....	11
A		
Accuracy of display readout (parameters 009-012, Display readout):		25
Available literature		2
C		
Cable lengths and cross-sections:		24
Control card, 24 V DC supply:		24
Control card, analogue inputs		23
Control card, digital inputs:.....		22
Control card, digital/pulse and analogue outputs:		23
Control card, RS 485 serial communication:.....		24
Control characteristics:.....		25
E		
External 24 Volt DC supply		24
Externals.....		25
F		
Fuses.....		38
H		
Harmonic filter		16
Harmonic filters		21
M		
Mains supply (L1, L2, L3):		22
Max. imbalance of supply voltage:		22
MCT 10		12
Mechanical dimensions		40
O		
Ordering form		10
P		
Profibus DP-V1		12
PC software.....		11
PC Software tools		12
Protection		26
R		
Relay outputs:.....		24
S		