

Servodyn-T / Servodyn-D

EMC Manual Servodyn-T, -D

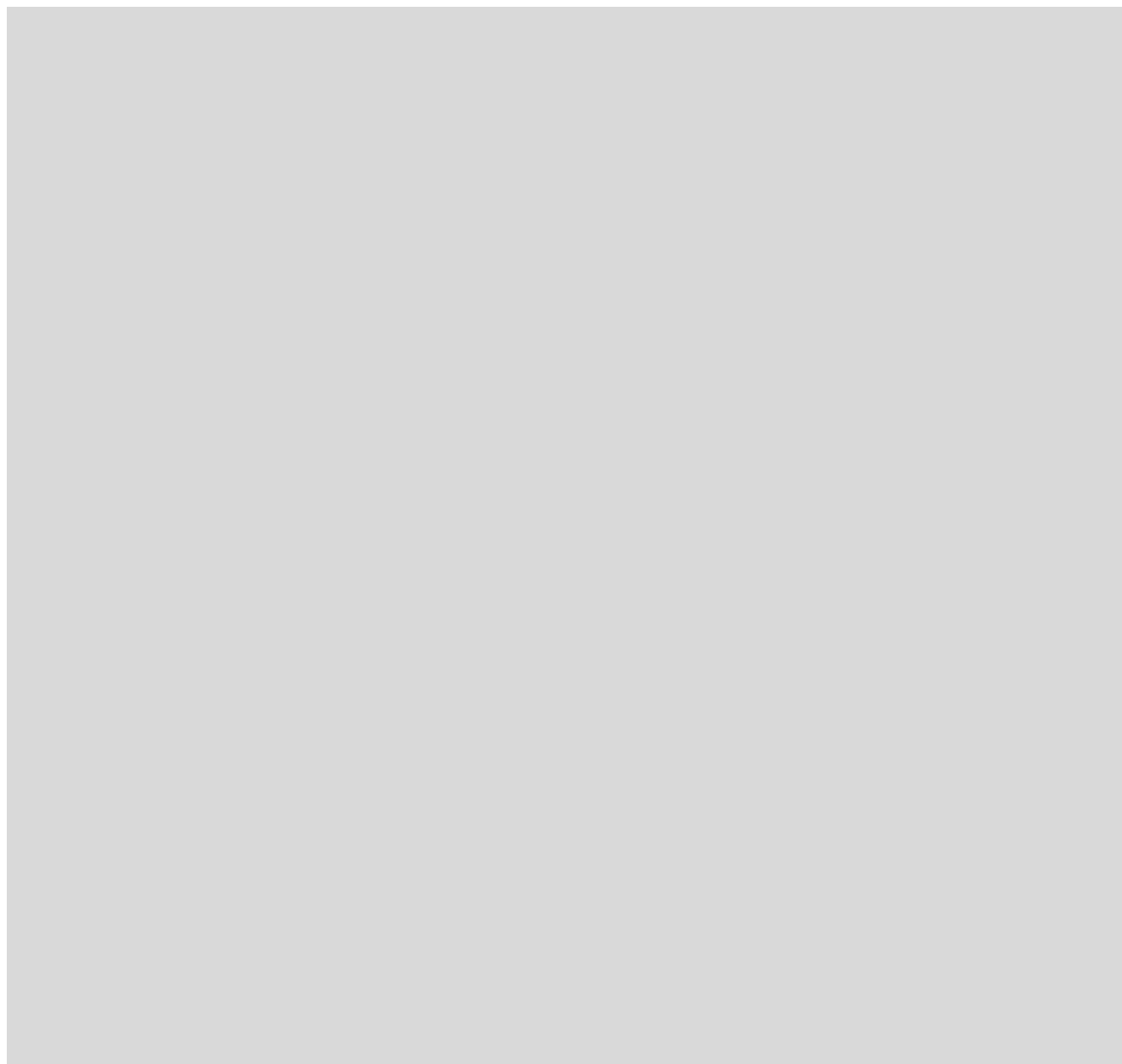

Version

101



Servodyn-T / Servodyn-D

EMC Manual Servodyn-T, -D

1070 066 074-101 (96.07) GB



Reg. Nr. 16149-03

© 1996

by Robert Bosch GmbH,
All rights reserved, including applications for protective rights.
Reproduction or handing over to third parties are subject to our written permission.

Discretionary charge 10.– DM



Contents

	Page
1	Safety instructions
1.1	Markings on components 1-1
1.2	Hazard warnings in the manual 1-1
1.3	Qualified personnel 1-2
1.4	Proper use 1-3
2	Installing Servodyn drive systems according to EMC 2-1
3	Switch cabinet structure
3.1	Mains supply 3-1
3.2	Basic configuration 3-1
3.3	Information on installation for Servodyn-T 3-3
3.3.1	General notes 3-3
3.3.2	Configuration with VM 50, VM 60, VM 60/EB 3-4
3.3.3	Configuration with 60/R and VM 100/R 3-5
3.4	Information on installation for Servodyn-D 3-6
3.4.1	VM...K with typical configuration 3-6
3.4.2	VM...B,C,D 3-7
3.5	Earthing 3-8
3.6	Mains filters 3-14
3.7	DC/DC filter for 24 V supply 3-15
3.8	Filter terminal 3-15
3.9	Filter for holding brake 3-15
3.10	DC link connection 3-16
4	Motor lines, sensor lines
4.1	Basic procedures 4-1
4.1.1	Cable ducts 4-1
4.1.2	Screen connections 4-2
4.2	Lines for tool machines 4-2
4.3	Lines in special machines and in systems 4-3
5	Typical configuration
5.1	Servodyn-T 5-2
5.2	Servodyn-D 5-4



6	EMC ambient conditions	
6.1	Domestic, business, commercial sectors	6-1
6.2	Industrial sector	6-1
6.3	Other areas of application	6-2
6.3.1	Transportation and road traffic	6-2
6.3.2	Energy supply	6-2
6.3.3	Special	6-2
6.3.4	Information-technology apparatus	6-2
7	Legal basis of EMC	
7.1	EU guidelines	7-1
7.2	EMC guideline	7-1
7.3	EMC law	7-2
7.3.1	Area of application (extracts)	7-2
7.3.2	Protection requirements (extracts)	7-2
7.3.3	Certificate	7-3
7.3.4	Definition of terms (extracts)	7-3
7.4	Standardised European norms	7-6
7.4.1	Application	7-6
7.4.2	EMC norms for the industrial sector	7-7
7.4.3	EMC norm for domestic, business and commercial sectors	7-8
8	Recommendations of CEMEP	8-1
9	Order numbers	9-1
A	Appendix	
A.1	Safety notes	10-1
A.1.1	Dansk	10-1
A.1.2	Deutsch	10-3
A.1.3	Ελληνικά	10-4
A.1.4	Español	10-6
A.1.5	Français	10-8
A.1.6	Italiano	10-9
A.1.7	Nederlands	10-11
A.1.8	Português	10-12
A.1.9	Suomi	10-14
A.1.10	Svenska	10-15



1 Safety instructions

This manual contains information which is required for the correct use of the products described here.

It is intended for technically qualified personnel who have been specifically trained in or who have relevant knowledge of measuring technology and automatic control engineering.

1.1 Markings on components

The following symbols are found on various components and are used as warnings to point out possible danger, or to call your attention to important information:



➤ Danger due to high voltage



➤ Electrostatically sensitive devices



➤ PE conductor



➤ Screen

1.2 Hazard warnings in the manual

Observe and comply with the safety notes and danger warnings given in this manual (“DANGER”, “CAUTION”, and the highlighted information provided under “Note”) in order to avoid serious injury and property damage.

All safety instructions are numbered sequentially in accordance with the chapter in which they appear, for example 1.1. The Appendix provides translations of the safety instructions in all official EU languages.



1.3 Qualified personnel

1.1



! DANGER !

Maintenance and installation of the components to be carried out only by electrotechnicians (VDE 1000-10) under observation of the accident prevention regulations and installation regulations (EN 60204-part1, prEN 50178).

Tampering with the drive components, ignoring warning signs attached to the components, or noncompliance with the warning notes given in this manual can result in serious bodily injury or property damage.

For this reason, only **electrotechnicians** as recognized under VDE1000-10 who are familiar with the contents of this manual may perform the procedures as authorized in this manual.

Such personnel are

- those who, being well trained and experienced in their field and familiar with the relevant norms, are able to analyse the jobs being carried out and recognise any hazards which may have arisen.
- those who have acquired the same amount of expert knowledge through years of experience that would normally be acquired through formal technical training.

Please note that we offer a comprehensive training program. You will find an overview of our seminar program on the inside back page. Our training centre will be pleased to provide you with further information.



1.4 Proper use

Drive inverters are components to be installed in metal machines and systems for industrial use.

With the appropriate adjustments and extensions they can also be used for commercial use.

- Before putting the drive inverters into operation, ensure that the machine which the inverters are to be installed in meets the stipulations of the machine guideline (89/392/EEC) and the EMV guideline (89/336/EEC).
- The inverters themselves meet the protection standard goals of the undervoltage guideline (73/23/EEC) and the co-ordinated norms prEN 50178 (VDE 0160) and EN 60146-1-1 (VDE 0558-11).

These products pose no danger to persons or property if they are used in accordance with the handling stipulations and safety notes prescribed for their configuration, mounting, and proper operation.

! DANGER !

The safe and reliable operation of this product requires its proper transport, storage, set-up and assembly as well as conscientious operation and use.

1.2



Ensure that no components are bent and no insulation distances are changed at the inverters. Do not touch any electronic components and contacts.

CAUTION !

Drive inverters contain electrostatically sensitive components which can easily be destroyed if handled improperly.

1.3

! DANGER !

Do not allow the housings of electrical components to be destroyed, as this could cause personal injury.

1.4



Your notes:

2 Installing Servodyn drive systems according to EMC

The “Electromagnetic compatibility (EMC)” of a unit means that the unit concerned meets certain protection requirements:

Basic protection requirements

- The **generation** of electromagnetic interference must be limited to a point where it is possible to realise proper operation of radio and telecommunications units as well as other units.
- The **resistance** to electrical interference must be designed to enable proper operation.

Secondary protection requirements

- The interference immunity of units in an EMC surrounding area must be high enough that their operation will not be impaired by the interference emitted by other units within this area.

In order to meet the requirements of the EMC law, machines and systems must be designed and constructed so as to be electromagnetically compatible.

- Chapter 3 of this manual explains the basic construction of the switch cabinet in accordance with EMC.
- Chapter 4 describes special features of motor and sensor lines.
- Chapter 5 contains typical configurations which meet the requirements of the EMC law.
- Chapter 6 describes the EMC environments with their requirements and measurement conditions. Information here may help if EMC-related problems arise.
- Chapter 7 provides an overview of the guidelines, laws and norms related to EMC.
- Chapter 8 expands on the information in the CEMEP recommendation, the European committee of the manufacturers of electronic machines and the power electronics industry.



Note

This manual includes general information concerning EMC-oriented installation of Bosch Servodyn drive systems. It should not, however, be seen as a substitute for product-specific books, which should be read in addition to this manual.

This manual corresponds to the latest developments in the applicable EMC stipulations relating to Bosch Servodyn drive systems. Although this manual was produced with the utmost care, Bosch does not accept any responsibility or liability for individual applications on the part of the user, particularly in those cases where neglect, non-observance, error, misunderstanding or misinterpretation are involved.



3 Switch cabinet structure

3.1 Mains supply

Only a TN-S system should be installed inside the switch cabinet of a machine or system. A TN-S system is a 5-conductor system with separate lines for N-conductors and PE-conductors.

Use only one 4-conductor system without an N-conductor for the 400V~ three phase connection.

Employ 400V~/230V~ isolating transformers to supply the ultimate consumers with 230V~ nominal voltage. The N-conductor should only be earthed on the 230V~ side, preferably at the transformer.

Use 400V~/18V~ three-phase safety transformers with rectifiers in three-phase bridge connection for the supply of the ultimate consumers with 24V nominal voltage, or install 24V power supply units with 400V~ nominal voltage on the mains side.

3.2 Basic configuration

The introduction of voltage-source converters driven directly from the mains power supply and used for the high-dynamic speed control of feedrate and main spindle motors, as well as of the accompanying deployment of modern capacity transistors has led to an increase in the significance of interference.

Only a screening laid on both sides in connection with a strongly meshed earthing can offer sufficient protection against major interference for measurement and control lines!

The following points must be considered in the layout of the drive components:

- All drive components should be arranged so as to be mounted practically adjacent to each other and spatially separated from other electronic components such as CNC or PLC control units (distance >100 mm).
The switch cabinet area, affected by a high rate of interference from the drives, is separated from the surrounding area by filters. The filters are mounted as EMC barriers along an imaginary line.
- If present, a mains line reactor should be mounted close to the supply module. The shorter the connection, the lower the level of interference.
- All drive inverters on a DC link are to be configured in series. A two-row structure is, however, also possible. Observe section 3.10 as well as other information in the drive manuals.

- Motor lines and control lines must be routed separately (distance > 100 mm).
The following scheme can be adopted in the case of larger cabinets:

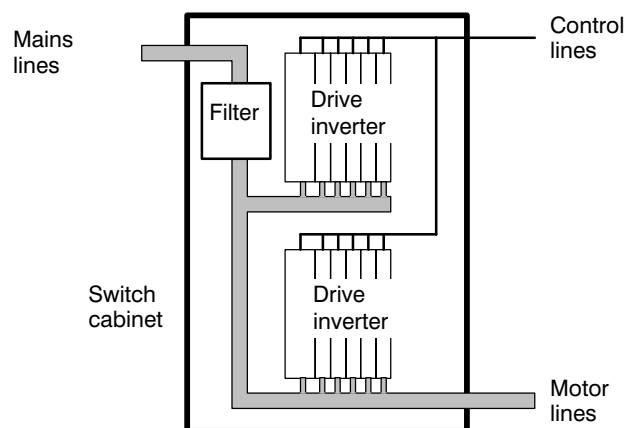

- When mounting the inverter system or the motors, be sure to take into account the information in the relevant manuals.
- The presence of strong magnetic fields means that components which are sensitive to magnetic interference (Inductosyn measuring systems) may not be installed near the motors.
Place the motor lines between the switch cabinet and the motor in the metal cable channels.



3.3 Information on installation for Servodyn-T

3.3.1 General notes



Note Take into account the required EMC environment when configuring the switch cabinet. 6).

- The mains line reactor and start-up switching module are to be installed in close proximity to the supply module. This has the advantage of a cooling effect through the air emitted from the top of the module while at the same time creating no more than a slight amount of interference through the short connections.
- Retain a distance of ≥ 500 mm between the mains line to the mains filter and the motor lines. This prevents the entry of interference from the motor lines into the mains line.



Note The presence of ferrite annular cores on the motor lines can prevent interference with a distance of < 500 mm.

- Type KM-T capacitor modules are necessary to support the DC link. At the same time they provide, in conjunction with the mains line reactor, protection against overvoltages in accordance with DIN VDE 0160. They should therefore be connected with the copper strips included in the connection accessories to the DC link.

3.3.2 Configuration with VM 50, VM 60, VM 60/EB

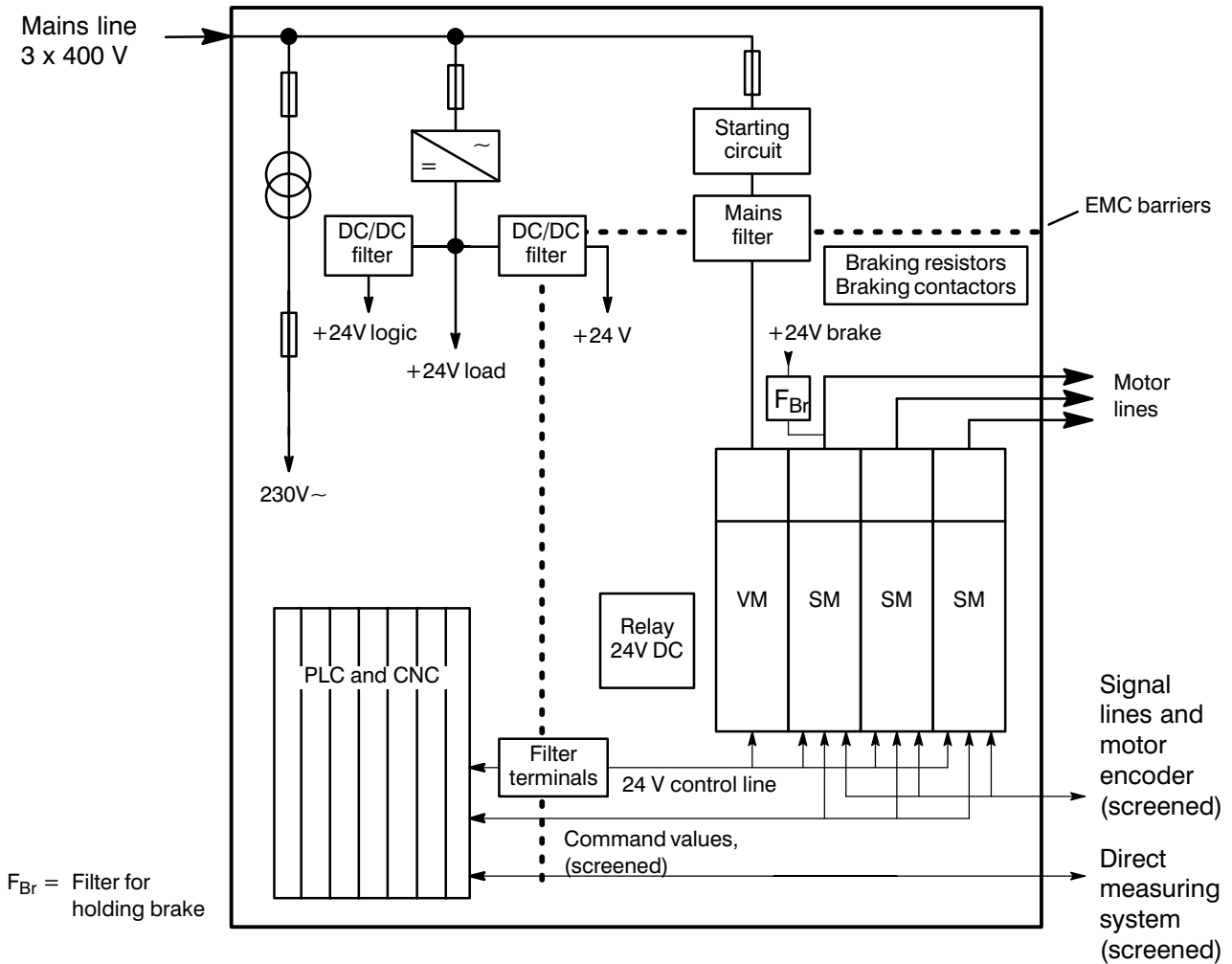

Fig. 2.1: Basic configuration of switch cabinet for Servodyn-T for small to medium capacity up to SM 25/50 (ASM 25; SPM 25) with VM 50, VM 60, and VM 60/EB

3.3.3 Configuration with 60/R and VM 100/R

Fig. 2.2: Basic configuration of switch cabinet for Servodyn-T for medium to high capacity with VM 60/R, VM 100/R

3.4 Information on installation for Servodyn-D

 **Note** Take into account the required EMC environment when configuring the switch cabinet (see chapter 6).

3.4.1 VM...K with typical configuration

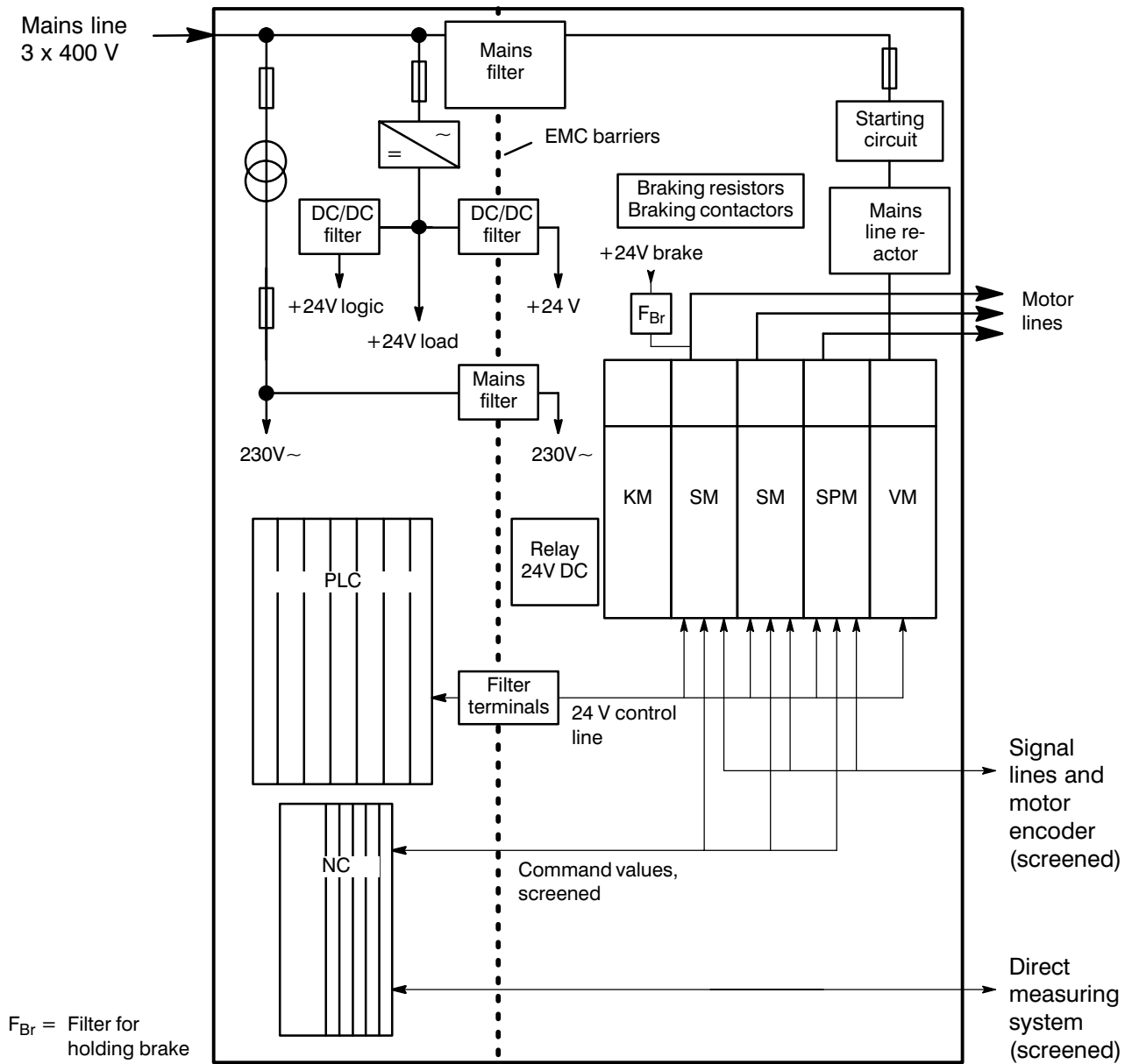
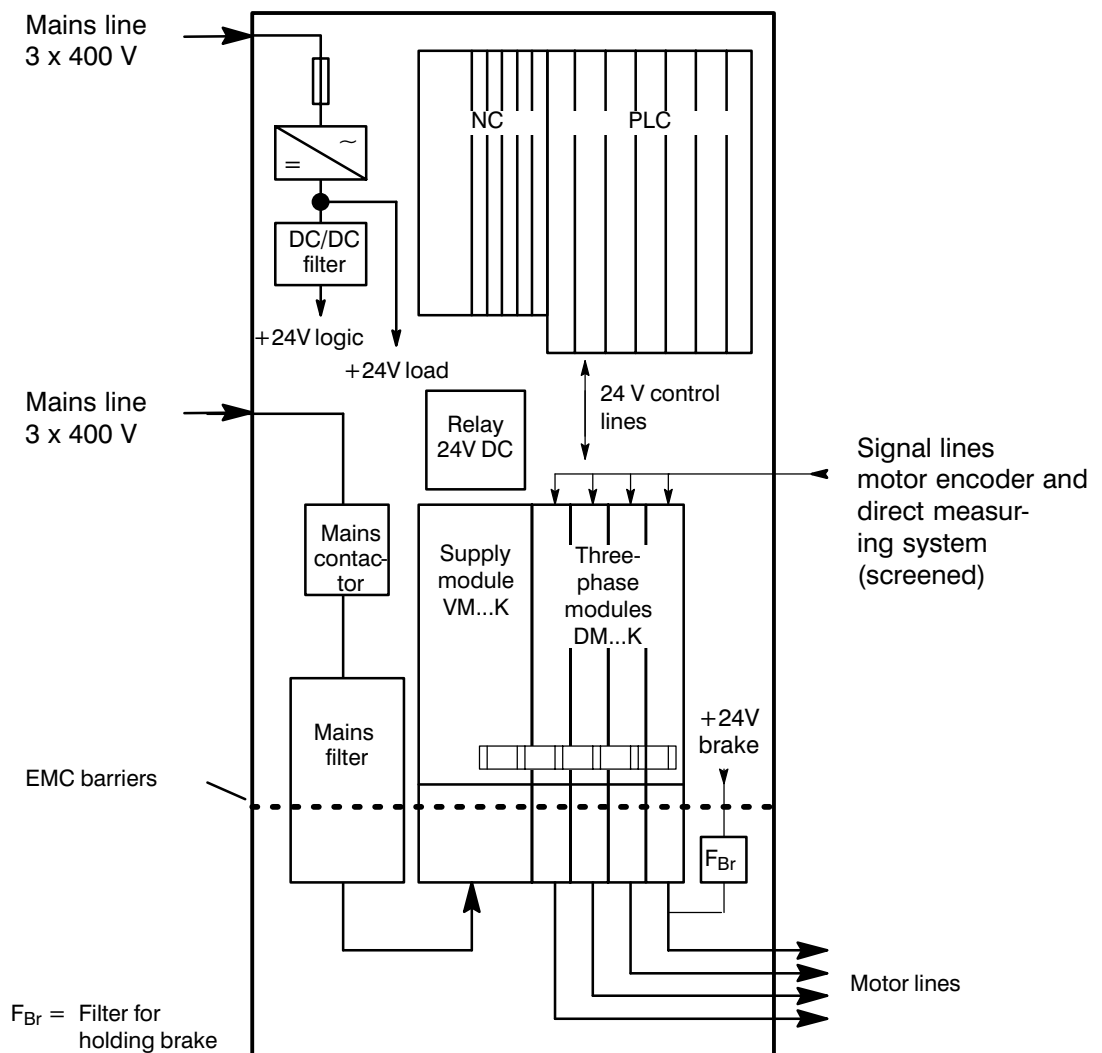

Fig. 2.3: Basic switch cabinet configuration for Servodyn-D for small to medium capacity with VM...K

3.4.2 VM...B,C,D

- Mount the mains filter as close as possible to the mains connecting module.
- Mount the mains line reactor as close as possible to the mains connection module.
Shorten the line ends of the mains line reactor to the necessary length, as short connections mean less interference.

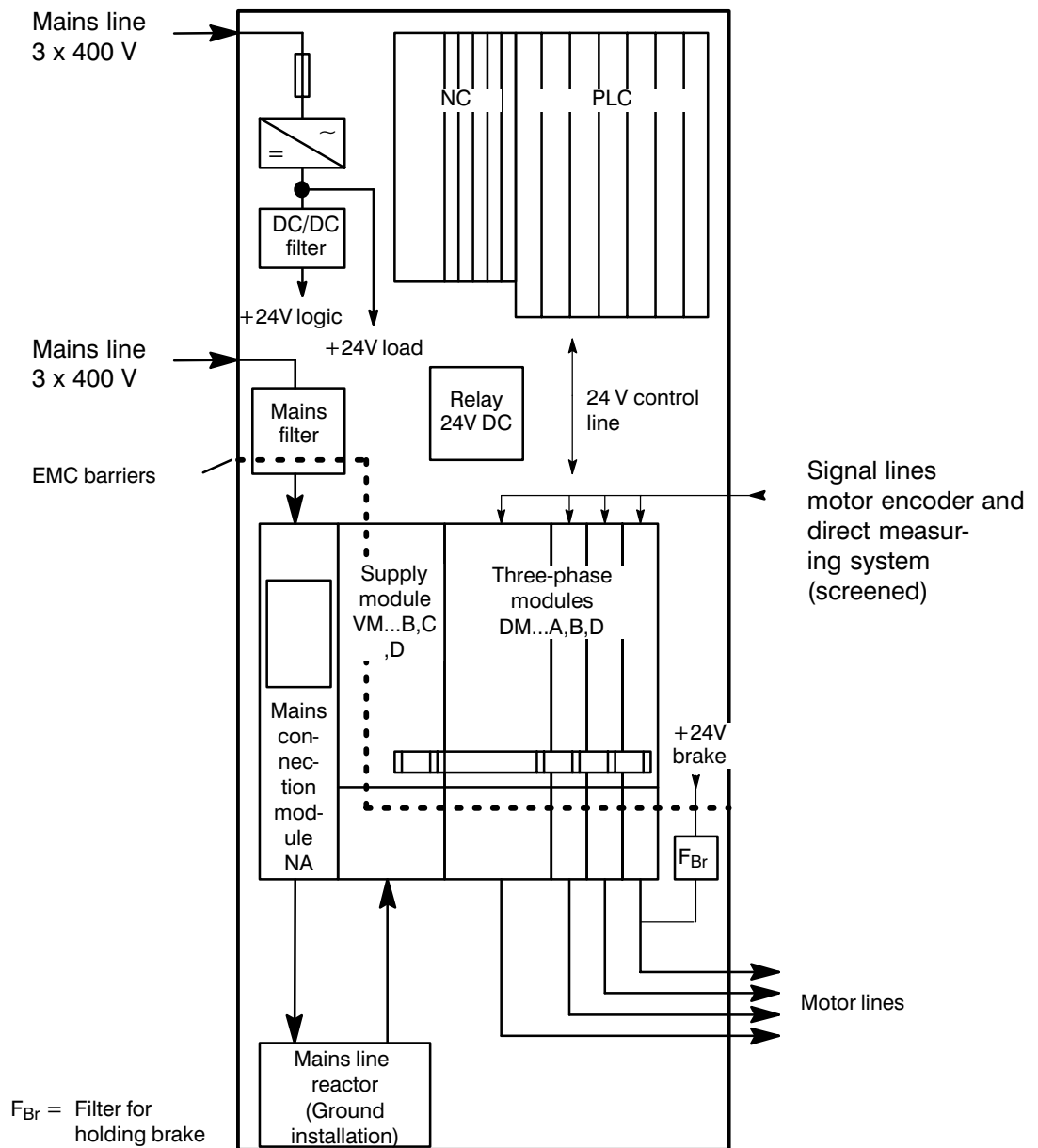

Fig. 2.4: Basic switch cabinet configuration for Servodyn-D for medium to high capacity with VM...B,C,D

3.5 Earthing

The following are taken into account as a part of the earthing plan:

- protective earth** as protection against dangerous shock currents
- functional earthing** as protection for sensitive electrical equipment

3.1



! DANGER !

**Dangerous shock currents due to insufficient PE conductor connections.
Do not allow PE conductor connections to be impaired by mechanical, chemical or electrochemical influences. The connection should be permanently fixed.**

The equipotential bonding should be configured in mesh or surface form as it then has a smaller impedance than a point-to-point equipotential bonding. Loops in the earthing system have a reducing effect with mesh-type equipotential bonding, as the magnetic field of the induced currents is inverse to the exciting magnetic field.

Surface-type equipotential bonding is:

- the mounting plate in the switch cabinet
- the surface of the metallic machine frames which the motors are attached to.

To prevent circulating currents at system frequency, all system parts should, if possible, be supplied from one connecting point of the supply system.

Equivalent circuit diagram for high-frequency interference currents (↻)

High-frequency interference currents are created by coupling capacitances in the inverter, in the motor lines and in the motor.

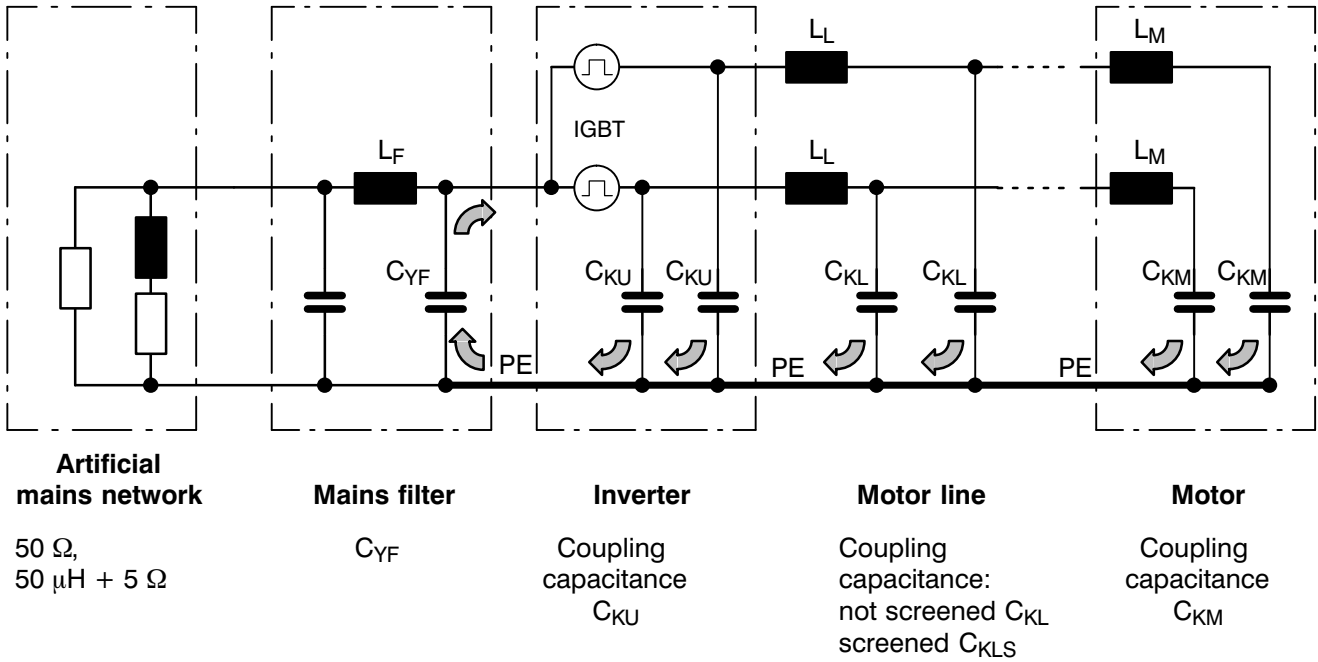

Range	C _{YF}	C _{KU} per inverter	C _{KL} per motor and 10 m length	C _{KLS} per motor and 10 m length	C _{KM} per motor
16 - 25 A	125 - 240 nF	0,5 nF	0,7 nF	2,2 nF	1 nF
50 A	800 nF	1 nF	0,6 nF	1,8 nF	4 nF
80 A	1350 nF	2 nF	0,6 nF		



Note The PE conductors must be continuously wired from the motors via the PE buses of the inverter housings to the PE terminal of the mains filter. This prevents stray interference currents. The majority of interference in the system (machine) depends essentially on the version of this PE connection.

Protective earth modules Earth connections in the switching cabinet must be designed in the form of a grid mesh.
The module housing and mounting plate of the switching cabinet must be earthed.
The connection between mains filter and supply module should be as short as possible.

Servodyn-T:

The cross section of the protective earth must correspond to that of the mains supply cable to the supply module.
A cross connection is made with the attached buses on the top side of the module.

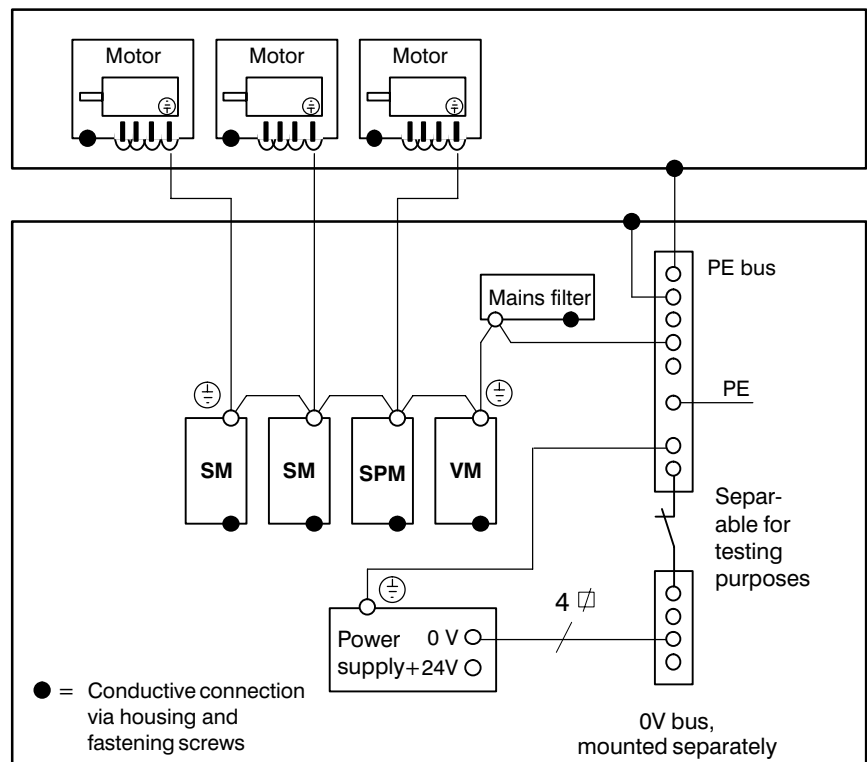

Fig. 2.5: Earthing plan Servodyn T

Servodyn-D:

The cross section of the protective earth must correspond to that of the mains supply cable to the supply module.

- **VM...B,C;D and DM...A,B,D:**
Starting at the mains connection module, a continuous connection is established on the bottom of the backplane module RM with the available earthing links.

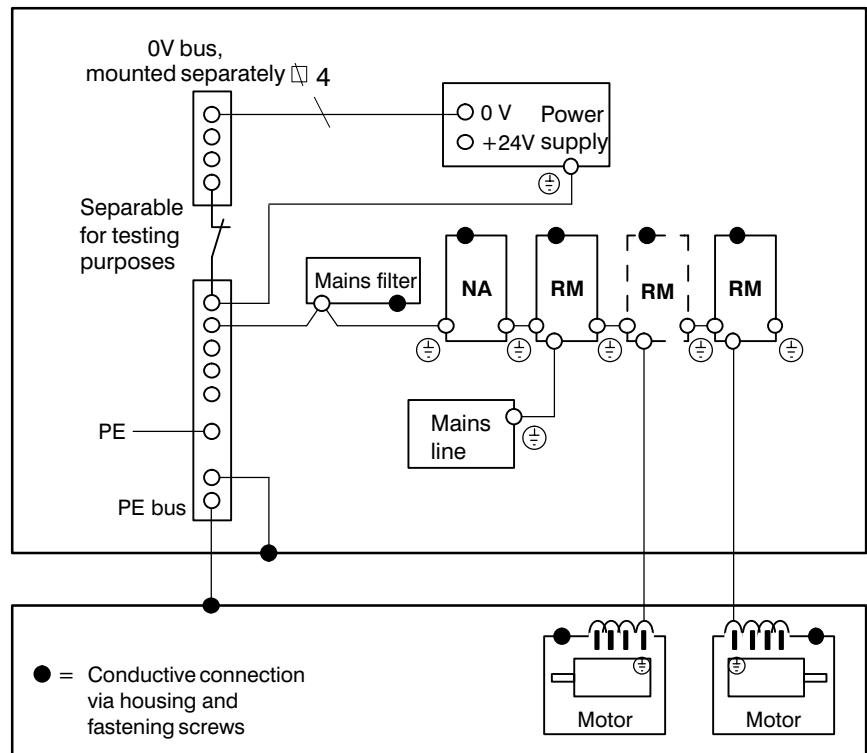

Fig. 2.6: Earthing plan Servodyn-D with VM...B,C,D

- **VM...K, DM...K:**
Starting at the VM supply module (or alternatively from the NV), a continuous connection is established on the bottom of the modules with the attached buses.

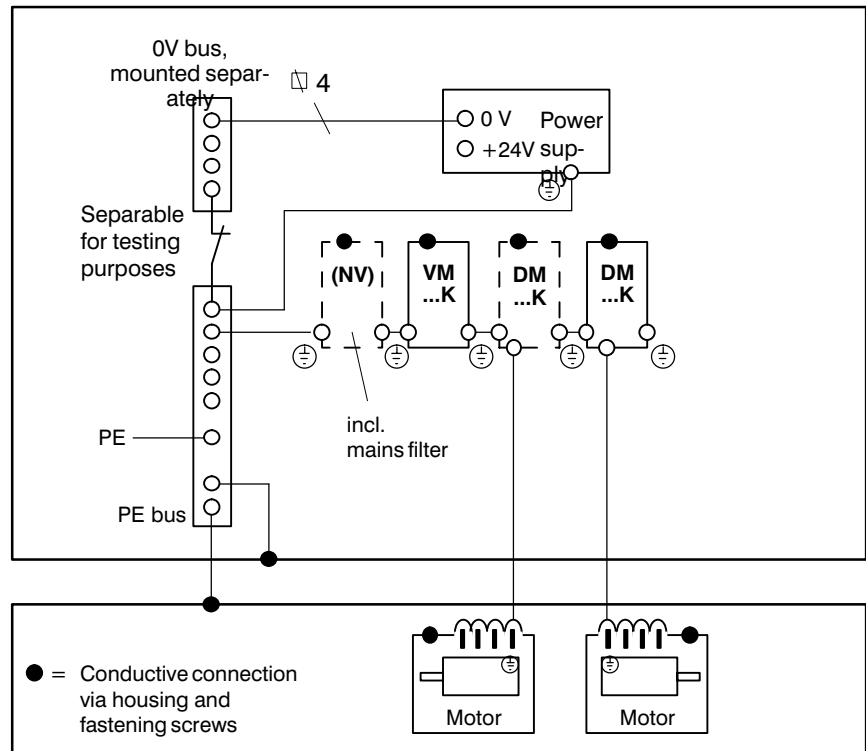

Fig. 2.7: Earthing plan Servodyn-D with VM...K

Protective earth, motors

In accordance with DIN VDE 0160, the PE wire cross section must be designed for $\sqrt{3}$ -times the nominal load of the power conductors in case a fault occurs.

If there are at least two motors present at the machine which are connected to each other via the housing, the PE wire cross section has grown accordingly in size and the condition mentioned above has been fulfilled.

Asynchronous motors QUV, DU and servo motors SE-B5

In this power range, the protective PE conductor incorporated in the line becomes a source of interference where the motor lines are over 20 m long. The high dU/dt values cause capacitive interference from the power wires to the PE conductor. The resulting circulating current leads to differences in potential between the machine and the switch cabinet.

In such cases, it is necessary to install a second PE conductor in the terminal box of the motors, leaving a distance of >100 mm from the power cable.

**PE bus**

The cross section of the PE bus and mounting plate earthing must be one level wider than that of the mains supply cable to the supply module.

**24 V power
supply module**

The PE connection and the secondary circuit earthing must be designed in accordance with the secondary current, but must have a cross section of at least 1,5 mm².

0 V bus

The 0 V bus is provided with insulation and earthed at one place only. This prevents 24 V operating currents in the earthing and screen connections.

3.6 Mains filters

When a filter is installed in the mains supply cable the interference limit values A or B depending on the filter type are adhered to in accordance with the EN 55011 (DIN VDE 0875-11).

! DANGER !

Mains filters contain capacitors and discharge resistors which still carry lethal voltages even after the mains voltage has been switched off.

Do not touch the power terminals with a tool until at least 10 seconds have passed!

Use a mains filter in the drives' supply line in order to avoid mains-borne disturbance voltages in the supply system:

- Attach the filter directly to the partition so that the incoming cables have the shortest path through the partition to the filter.
- If this is not possible, it will be necessary to preserve a continuous distance of > 500 mm between the mains supply cable to the mains filter and the motor lines.

 **Note** The effectiveness of the filter is determined by the quality of the filter's earthing connection:

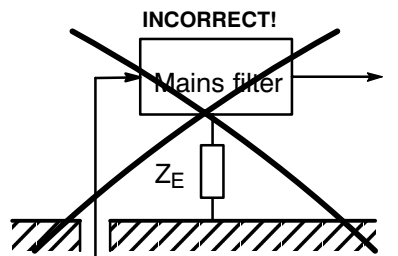

Earth connection by means of connection lead to the metal housing

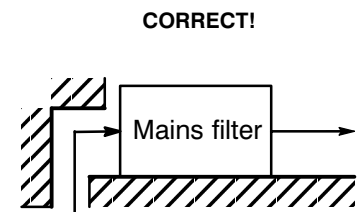

Flat chassis earth connection to the metal housing via press-in bolts or press-in nuts (cold weld joint)

 **Note** The effect of the filter is determined to a great extent by its placing within the switch cabinet.

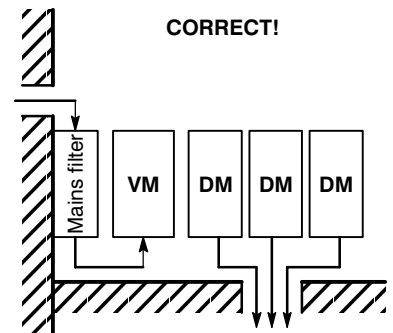
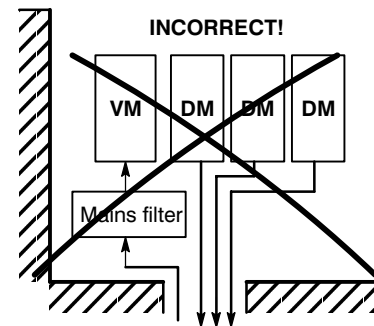



3.7 DC/DC filter for 24 V supply

Version:

Eichhoff, type EE F33 060/5, 24 V/10 A

DC/DC filters are necessary in order to:

- provide a filtered 24 V supply for the PLC and NC logic units from the 24 V load voltage
- provide interference suppression for the 24 V supply voltage for the drives, which is vulnerable to interference due to its inevitable proximity to the motor lines.

It is also possible to employ a filter terminal in the +24 V line and the 0 V line instead of the DC/DC filter.

3.8 Filter terminal

Version:

Two-tier terminal SLKK5, from Phönix.

Remove the lower terminal, install a 0.22 μ F sealed capacitor (flat section). Connect the capacitor between the upper terminals and the PE terminal.

Sealed capacitor, Rutronik, type 0,22 μ F 160 V-
 Thomson, type SA 18 0,22 μ F 100/160 V
 or equivalent

3.9 Filter for holding brake

The 24 V lines for the holding brake control up to size 5 are usually incorporated in the motor line.

Due to their close proximity to the motor phases, the 24 V lines are very vulnerable to interference, and must therefore be provided with filters to suppress the interference.

Both the 24 V brake control unit and the 0 V return line must be interference-suppressed. The filters should be installed in the motor line as close as possible to the supply point of the brake control unit.

Version:

Filters for brake supply, type HI 50007-101,
2 x 0,22 μ F 160/250 V, in a plastic housing, each with one connection point for 24 V brake control, 0 V return line and PE.

(Order no., see section 9)

It is also possible to use two filter terminals as in section 3.8

3.10 DC link connection

This connection is usually made with the attached buses. A spatial separation of up to 3 m is allowed for smaller auxiliary axes.

-  **Note** Due to the high dI/dt values in the DC link, the extension cable for the DC link has the effect of an inductive interference source. Line screens made of copper braiding have essentially no effect here. It is therefore vital that the extension cable is layed out a distance of at least 100 mm from all other cables.

4 Motor lines, sensor lines

4.1 Basic procedures

4.1.1 Cable ducts

In order to avoid high-frequency thermal radiation, power connections from the switching cabinet to the motor should be laid in completely enclosed metal cable ducts.

In the case of multi-chamber cable ducts, encoder cable should also be laid in a separate chamber in the cable duct.

The cable duct is connected over a large area with machine parts and the switch cabinet.

Standard

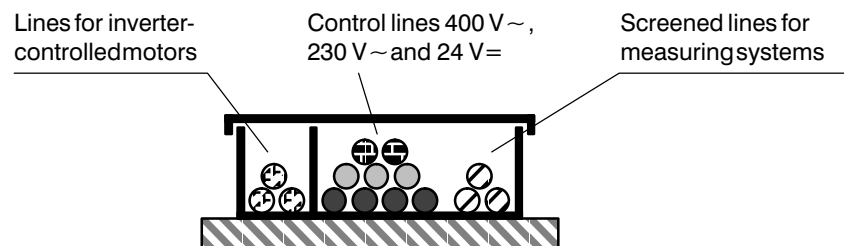

Fig. 4.1: Cable duct with two chambers

For measuring systems with sinusoidal signals

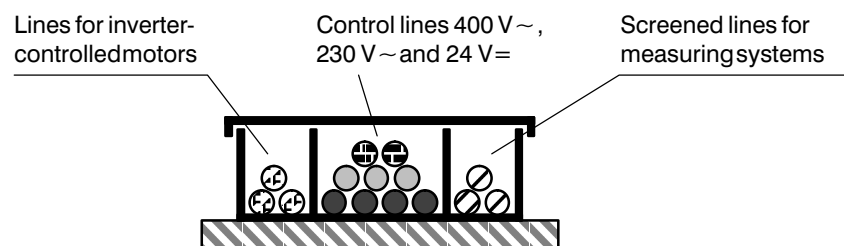

Fig. 4.2: Cable duct with three chambers, necessary for employment of sensitive measuring systems with sinusoidal signal transmission

For measuring systems with sinusoidal signals and interference-prone PLC-I/O's

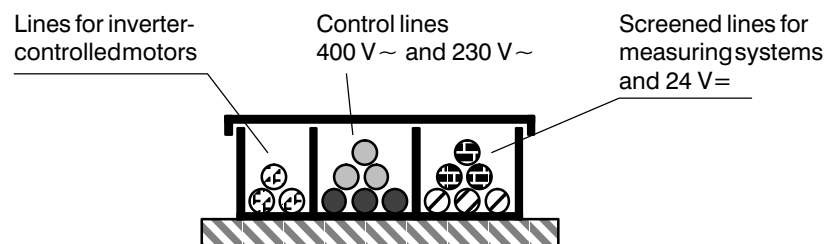

Fig. 4.3: Cable duct with three chambers, necessary for sensitive measuring systems with sinusoidal signal transmission and PLC control units with interference-prone I/O's

4.1.2 Screen connections

Screened lines should be used for:

- command lines
- tacho lines
- incremental encoder lines

The screens must be earthed at both ends. The screen may not be interrupted at plug connectors.

The line screen should be made of aluminium foil or copper braiding, with high conductance and a completely surrounded inner conductor.

Tacho and encoder are connected via a special line (max. length 100 m), the screen of the latter being connected to the metal housing of the connectors.

Use the ready-made lines or observe the connection conditions in the ap-pertaining manuals.

4.2 Lines for tool machines

Tool machines generally have metal covers for protection against me-
chanical hazards.

This reduces the interference emission from the machine, thereby remov-
ing, to a great extent, the need for screened motor lines within metal cov-
ers.

Ferrite annular cores on motor lines reduce electromagnetic emissions in
the frequency range > 30 MHz, see typical configurations in section 5.



Note **The PE conductor may not be routed via the ferrite annular cores. The conductor coat of the motor line is removed next to the terminal block of the module and the three motor phases are routed together through a ferrite annular core.**

Ferrite annular cores: (Order no., see section 9)

Outer diameter: 28 mm
Inner diameter: 16 mm
Length: 20 mm

4.3 Lines in special machines and in systems

Special machines and systems do not generally have closed covers. They can also be distinguished by the larger dimensions which require motor lines longer than 25 m.

Unscreened motor lines

In order to reduce interference emissions, the motor lines should be as short as necessary and generally in or directly on top of metal structural parts, e.g.

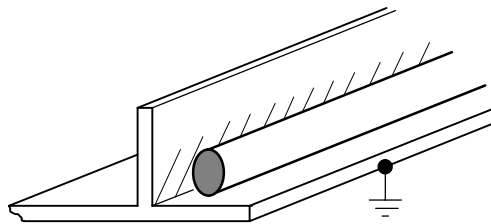

If there are no metal structural parts present, use screened lines. Ferrite annular cores reduce electromagnetic emissions in the frequency range > 30 MHz, see typical configurations in section 5.

Screened motor lines

Where screened lines and lengths of over 25 m are involved, the mains filter is put under additional strain from the considerably larger coupling capacities. They may also cause operation-related shutdowns. The interference voltages on the mains supply cable must therefore be measured and, if necessary, the type B mains filter employed.

Ferrite annular cores are also required with screened motor lines, as they reduce electromagnetic emissions in the frequency range > 30 MHz, see typical configurations in section 5.

Long lines

Long lines are prone to frequent gains and losses of interference. This effect can be minimised by laying out interference-emitting and interference-sensitive lines separately.

The required distance between motor lines and control lines is:

- > 100 mm with parallel laying of < 10 m
- > 250 mm with parallel laying of > 20 m

Install the drive inverter close to the motors in order to ensure, if possible, that motor lines do not exceed 25 m in length.

Crossed lines

Where lines are crossed, interference will be at its lowest if the angle at which they cross is 90° .

Interference-sensitive lines should therefore cross motor lines or ballast resistor lines only at an angle of 90° .

Output filters

Motor impeders, dU/dt filters or sinusoidal filters can only be employed for frequency converters or controlling the standard motors.

These output filters may **not be employed** for servo drives and mains spindle drives.

Your notes:



5 Typical configuration

Where proper use is observed, the limit values for the interference voltage at the power supply connection and for the interference emission from devices belonging to Group 1 Class A (industrial sector) will not be exceeded by the following typical configurations.

The measurement record will confirm that the limit values are not exceeded.

1. Measurement of the interference voltage on the mains supply cable (150 kHz up to 30 MHz)

- Measurement configuration acc. to CISPR with an artificial mains network 3 x 400 V/16 A or 3 x 400 V/32 A (50 A)
- Limit values for ISM devices belonging to Class A, Group 1 acc. to EN 55011 (CISPR 11), industrial sector
- Measurement record on request
- Measures for installation in domestic, business, commercial and small enterprise sectors on request.

2. Measurement of interference emission (30 MHz to 1000 MHz)

- Measurement of the interference emission at an alternative measuring point 10 m away.
Due to the short measuring distance (10 m instead of 30 m), the limit values are raised by 10 dB μ V, see also EN 50081-2 and CISPR/1073/CD April 95.
- Measurement configuration acc. to CISPR, 10 m measuring distance on a ground plane. The ground plane consists of a copper foil screen layed out on the ground.
The drive modules and the mains filter are mounted on a galvanized steel plate on a 0.8 m high wooden table. The motors are on a Europallet under the wooden table.
The distance between the power line and motor line is > 0.5 m.
Mains power is supplied from a switch cabinet 10 m away, the 24 V supply from a power supply module 10 m away.
- Limit values for ISM devices belonging class A, Group 1 + 10 dB μ V in acc. with EN 55011 (CISPR 11), industrial sector.
- Measurement record on request.
- Measures for installation in domestic, business, commercial and small enterprise sectors on request.

5.1 Servodyn-T

Typical configuration with VM 50:

Components	Version	Order no.
Supply module	1 x VM 50/B -TC1	1070 060 838
Mains filter	1 x 440 V/ 25 A Cl. A	1070 918 476
Ferrite annular core for power line from mains filter to VM	1 x Ø 28 mm x 20 mm	1070 918 505 ¹⁾
Inverter modules	1 x SM 5/10 -TC1 1 x SM 10/20 -TC1 1 x SM 15/30 -TC1	1070 065 667 1070 065 668 1070 065 669
Motors	1 x SE-B2.020.030-00 1 x SE-B3.055.030-00 1 x SE-B4.130.030-04	1070 915 684 1070 915 109 1070 914 614
Motor line	unscreened: 10 m, 6 x 1,5 mm ² (SE-B2) 10 m, 6 x 2,5 mm ² (SE-B3) 10 m, 6 x 2,5 mm ² (SE-B4)	
Ferrite annular cores for motor lines	1 x Ø 28 mm x 20 mm per motor line	1070 918 505 ¹⁾
Encoder line	screened: 3 x 10 m (SE-B2, -B3, -B4)	1070 903 499
Filter for brake supply (SE-B4.130.030.04)	1 x HI50007-101	1070 917 448
Command lines (analog command value)	screened: 3 x 2 m	1070 903 990
Control lines	unscreened: 2 m, 1,5 mm ² (24 V DC) 2 m, 1,5 mm ² (0 V DC) 2 m, 0,5 mm ² (BTB) 2 m, 0,5 mm ² (FG)	1070 902 699 1070 902 699 1070 903 450 1070 903 450

¹⁾ contains 20 ferrite annular cores in packaging for transport

**Typical configuration with VM 60/EB:**

Components	Version	Order no.
Supply module	1 x VM 60/EB -TA	1070 054 344
Mains filter	1 x 440 V/ 35 A Cl. A	1070 911 877
Ferrite annular core for power line from mains filter to VM	1 x Ø 28 mm x 20 mm	1070 918 505 ¹⁾
Capacitor module	1 x KM 2200 -T	1070 048 799
Inverter modules	1 x SM 5/10 -TC1 1 x SM 10/20 -TC1 1 x SM 15/30 -TC1 1 x ASM 25 -TD	1070 065 667 1070 065 668 1070 065 669 1070 068 439
Motors	1 x SE-B2.020.030-00 1 x SE-B3.055.030-00 1 x SE-B4.130.030-04 1 x 7,5 kW/380V/1500 rpm, auto-ventilated	1070 915 684 1070 915 109 1070 914 614 ATB RV 7,5/ 4-75 HRO
Motor line	unscreened: 10 m, 6 x 1,5 mm ² (SE-B2) 10 m, 6 x 2,5 mm ² (SE-B3) 10 m, 6 x 2,5 mm ² (SE-B4) 10 m, 4 x 2,5 mm ² (ASM)	
Ferrite annular cores for motor lines	1 x Ø 28 mm x 20 mm per motor line	1070 918 505 ¹⁾
Encoder line	screened: 3 x 10 m (SE-B2, -B3, -B4)	1070 903 499
Filter for brake supply (SE-B4.130.030.04)	1 x HI50007-101	1070 917 448
Filter for motor fan	1 x 420 V/6 A	1070 913 529 ²⁾
Command lines (analog command value)	screened: 3 x 2 m	1070 903 990
Control lines	unscreened: 2 m, 1,5 mm ² (24 V DC) 2 m, 1,5 mm ² (0 V DC) 2 m, 0,5 mm ² (BTB) 2 m, 0,5 mm ² (FG)	1070 902 699 1070 902 699 1070 903 450 1070 903 450

1) contains 20 ferrite annular cores in packaging for transport

2) The filter is necessary if fan and power supply are to be connected to the motor at the same terminal box

5.2 Servodyn-D

Typical configuration with VM 20...K:

Components	Version	Order no.
Mains connection module incl. mains filter 440 V/25 A	1 x NV 20/3F	1070 077 941
Supply module	1 x VMA 20KB 001-D	1070 077 300
Inverter modules	2 x DM 8K 1101-D 2 x DM 15K 1101-D	1070 077 601 1070 077 602
Motors	2 x SF-A2.0020.030 2 x SF-A3.0093.030	1070 076 396 1070 076 397
Motor line	unscreened: 2x10 m, 6 x 1,5 mm ² (SF-A2) 2x10 m, 6 x 1,5 mm ² (SF-A3)	1070 950 719 1070 950 719
Ferrite annular cores for motor lines	4 x Ø 28 mm x 20 mm	1070 918 505 ¹⁾
Encoder line	screened: 4 x 10 m (SF-A2, -A3)	1070 940 328
Filter for brake supply	1 x HI50007-101	1070 917 448
Command lines SERCOS interface	2 x 10 m optical fibres	1070 903 990
Control lines	unscreened: 2 m, 1,5 mm ² (24 V DC) 2 m, 1,5 mm ² (0 V DC) 2 m, 0,5 mm ² (BTB) 2 m, 0,5 mm ² (FG)	1070 902 699 1070 902 699 1070 903 450 1070 903 450

¹⁾ contains 20 ferrite annular cores in packaging for transport

6 EMC ambient conditions

The limit values for interference immunity and interference emission are defined differently according to the environment:

- Domestic, business and commercial sectors
- Industrial sector

Wherever the machine is installed, it must be ensured that the drive is interference-suppressed according to the EMC environment.

Servodyn drives can be employed, with the relevant additional measures, in any EMC environment.

6.1 Domestic, business, commercial sectors and small enterprises

All electrical/electronic appliances for connection to the public power supply (low voltage network with 1 x 230 V_{eff} or 3 x 400 V_{eff})

- Domestic appliances, heating and ventilation units, lifts
- Lighting appliances
- Equipment for petrol stations, garages, workshops
- Equipment for police, fire brigade, rescue services
- Equipment for public buildings, even if there is a transformer station present.
e.g.: banks, offices, department stores, theatres.

6.2 Industrial sector

All electrical/electronic appliances for connection to an industrial power supply.

An industrial power supply is distinguished by the following features:

- a separate transformer station with connection to the medium or high voltage network (e.g.: 4 kV or 110 kV)
- the presence of ISM devices (industrial, scientific and medical devices)
- large inductive or capacitive loads are switched frequently
- the current intensities are high, as are the magnetic field intensities affected by them.



6.3 Other areas of application

6.3.1 Transportation and road traffic

- Equipment for electric rail transport
- Equipment for traffic guiding systems and communication
- Electrical installations on ships
- Navigational instruments

6.3.2 Energy supply

- Testing devices and switchgears for high-voltage systems
- Equipment for protective devices
- Remote control, remote protection and telephone devices involved in energy supply
- Measuring and checking devices

6.3.3 Special

- Medical devices
- Electrical/electronic testing and measuring devices
- Equipment for audio, video and audiovisual apparatus

6.3.4 Information-technology apparatus

- Communication apparatus
- Modems
- Displays, display panels
- Screen terminals



7 Legal basis of EMC

7.1 EU guidelines

The EU guidelines define the basic safety requirements which products brought into circulation have to satisfy. This eases trade in goods within the EU and helps to prevent discrepancies between the different national requirements.

EU guidelines are passed by the EU Council and are applied to all EU member states. The latter are obliged to convert the guidelines into national law within the transitional period of time allowed.

The CE symbol was introduced in order that a product can be visibly designated as conforming to the appropriate guidelines. It indicates that the supplier (manufacturer, deliverer, importer etc.) has applied the conformity evaluation procedures included in the guidelines.

“CE” is the abbreviation for, for example, “Communautés Européenne” (European Community) in the majority of Romance languages.

The CE designation guideline 93/68/EEC July 1993 regulates the application of the individual EU guidelines relating to transitional time limits and CE designation.

7.2 EMC guideline

The EMC guideline 89/336/EEC was passed by the EU Council in May 1989. Defines the essential protection goals for public and private radio services as well as requirements concerning interference emission and interference immunity in devices containing electrical and/or electronic components.

The EMC guideline has been applicable since 01.01.92.

The EMC guideline was altered by guideline 92/31/EEC from April 1992 (definition of a transitional time period limit). National rulings could be applied selectively up to 31.12.95 (high-frequency device rule).

As of 01.01.96, only the EMC guideline is now applicable.

7.3 EMC law

The EMC rule of 09.11.92 stipulates the translation of the EMC guideline into national law.

The Federal Minister for Post and Telecommunications is (in Germany) responsible for this process. The Federal Office for Post and Telecommunications (BAPT) is (in Germany) the executory authority. The BAPT has set up a network of local branches which cover the sovereign territory of the Federal Republic of Germany.

Information is available from any branch of the BAPT, should you have any questions relating to EMC.

7.3.1 Area of application (extracts)

The EMC rule applies to devices which can emit electromagnetic interference or which may be affected operationally by such interference. It oversees the conditions for circulating, installing and operating such devices.

Devices which are intended solely for employment in special laboratories, workshops and rooms, installations which are assembled at the place of operation and not beforehand and networks do not require an EC Certificate of Conformity and the appertaining marking. The operator must, however, observe the relevant protection requirements.

Devices which cannot be operated automatically and which are manufactured and serviced solely as vendor parts or spare parts for subsequent use in industry, workshops or other firms familiar with electromagnetic compatibility are not required to comply with the protection requirements, nor do they require an EC Certificate of Conformity and the appertaining marking.

Spare parts are designed so as to cause no electromagnetic interference (when installed properly). This does not apply to assembly line construction kits or combinations of components for assembly by the operator, nor to generally available modules and device parts.

7.3.2 Protection requirements (extracts)

Construction of the devices must ensure that creation of electromagnetic interference is kept low enough to allow proper operation of radio and telecommunications devices as well as other devices.

The devices should have adequate resistance to electromagnetic interference, so as to allow proper operation.

The specifications required for proper operation of the device must be included in the enclosed operating manual.



7.3.3 Certificate

for compliance with the protection requirements and designation of the devices (extracts):

If the manufacturer of a device has applied the **standardised European norms**, certification is provided for compliance with the specifications of the EMC law. This is acquired by the manufacturer or authorised person resident in an EU member state in the form of an EC Declaration of Conformity.

The EC conformity mark is attached to the unit or, if this is not possible due to lack of space, on the packaging, the operating manual or the guarantee.

The devices, packaging and appertaining documents may only be awarded the EC conformity mark if they meet the protection requirements.

It is assumed that devices which comply with the conventional standardised European norms also meet the above requirements. These norms are translated into DIN VDE norms and the issuing authorities published in the official bulletin of the BMPT.

If the manufacturer of a device has applied the standardised European norms only in part or not at all, or if there are no applicable norms for the device in question, the protection requirements are considered satisfied if this is confirmed by certification from a competent body.

7.3.4 Definition of terms

(extracts)

Manufacturer Manufacturer is a person or body which is responsible for the design and production of a product which is subject to the EMC guideline or creates a new product from prefabricated products or makes alterations to, modifies or adapts a product.

Competent body The competent body is the body which issues technical reports or certificates concerning compliance with the protection requirements. It has to satisfy certain conditions and be recognised by the relevant authority or another authorised body of a European Community member state.

Bringing into circulation Bringing into circulation refers to the initial provision, free or against payment, of a product subject to an EU guideline for distribution and/or use within the EU.

Bringing into circulation does not include the following cases:

- the conveyance of the product from the manufacturer to the authorised body or importer who is contracted to take all measures necessary to bring the product into line with the guideline.
- introduction into the EU for the purpose of reexportation, e.g. within the framework of outward processing.
- manufacture of the product within the EU for the purpose of exportation to a third country
- exhibition of the product at trade fairs or exhibitions.

- Commissioning** Commissioning refers to the initial use of a product subject to an EU guideline by an end user within the EU.
- Device** A device is defined as an end product with a characteristic function, which is intended for the end user and is brought into circulation (see guide for application of the EMC guideline from May 1989). Devices must comply with the protection stipulations and bear the CE mark.
- Apparatus** An apparatus is synonymous with a device.
- System** A system consists of several devices which are designed and intended for combined operation.
A system is, for example, a personal computer with a monitor, keyboard and printer, which are designed by the manufacturer for combined operation and brought into circulation together. Systems must comply with the protection stipulations and bear the CE mark.
- Installation** An installation is an almost accidental combination of devices, systems and/or components which are assembled at the place of operation. This may involve a variety of configurations which initially cannot be defined. Installations must comply with the protection stipulations but do not bear the CE mark.
- Compliance with the protection requirements is assumed for installations,
- where the appertaining devices, systems and components comply with the protection requirements and bear the CE mark.
 - where the appertaining components do not, when supplied, meet the protection requirements according to §5, Para.5, Item 3, of the EMC law, but the protection measures required for the electromagnetic environment at the place of operation are carried out (e.g. filters, over-voltage diverters, isolating transformers, electromagnetic screen).
- The installation is to be installed/mounted at the place of operation by personnel with expert knowledge of EMC. Trouble-free operation of the entire installation can be guaranteed by complying with the installation/mounting instructions provided by the manufacturer of the devices, sytems and components.
- Components** A component is defined as any element which can be installed for use in a device or installation, but which has no independent function of its own. Note the distinction between:
- elementary components and
 - complex components.
- Elementary components** are discrete components such as resistors, capacitors, coils, small transformers/carriers, diodes/rectifiers, transistors/thyristors, integrated circuits, photoresistors, thermoelements, batteries/accumulators, fuses, lamps, terminals, plug connectors/connectors, sockets, mechanical switches etc.
- Elementary components are not required to comply with the protection requirements, nor do they need an EC Declaration of Conformity



or the CE mark.

Note that installations, devices and systems which are ready for operation and can accommodate these elementary components must comply with the protection requirements. Manufacturers of such installations, devices or systems must observe the designation rules in accordance with §5 of the EMC law.

Complex components are:

- elementary components which are attached to a common component carrier and are functionally coupled to each other galvanically, inductively, capacitively or by rays (e.g. thermostats, electronic cards etc.)
- electronic components (e.g. electromotors/generators, relays, moving coil instruments, loudspeaker chassis etc.).

Complex components must comply with the protection requirements. They require an EC Declaration of Conformity and must be provided with the CE mark.

Excluded from this under §5, Para.5, Item 3, EMC regulation are vendor parts or spare parts which are produced and stored solely for subsequent use in industry, workshops or other firms familiar with EMC. These components are not required to comply with the protection requirements, nor do they need an EC Declaration of Conformity or the CE mark.

Note that installations, devices and systems which are ready for operation and can accommodate these vendor parts or spare parts must comply with the protection requirements. Manufacturers of such installations, devices or systems must observe the designation rules in accordance with §5 of the EMC law.

7.4 Standardised European norms

It is assumed that devices which comply with the conventional standardised European norms (EN ...) also meet the protection requirements. If the manufacturer of a device has applied the European norms only in part or not at all, or if there are no applicable norms for the device in question, the protection requirements are considered satisfied if this is confirmed by certification from a competent body.

7.4.1 Application

EMC norms are arranged hierarchically as basic norms, generic norms, product family norms and product norms.

EMC basic norms EMC basic norms describe measuring methods for individual electromagnetic phenomena. They offer suggested test values, but do not generally include limit values.

EMC generic norms EMC generic norms describe electromagnetic ambient conditions. They provide limit values for individual electromagnetic phenomena according to the measuring methods in the EMC basic norms.

- EMC generic norms are **to be applied in part** where fundamental electromagnetic phenomena are not covered by EMC product norms or EMC product family norms.
- EMC generic norms **should not be applied** where EMC product norms or EMC product family norms are available.

EMC product family norms EMC product family norms provide limit values for individual electromagnetic phenomena according to the ambient conditions of the EMC generic norms and according to the measuring methods of the EMC basic norms for a product family.
EMC product family norms have precedence over EMC generic norms.

EMC product norms EMC product norms provide limit values for individual electromagnetic phenomena according to the ambient conditions of the EMC generic norms and according to the measuring methods of the EMC basic norms for a product.
EMC product norms have precedence over EMC product family norms and EMC generic norms.



7.4.2 EMC norms for the industrial sector

Interference emission

EMC generic norm

EN 50 081-2

published in official bulletin C49 from 17.02.94 (VDE 0839 Part 81-2):
1994-03 Electromagnetic compatibility (EMC) generic norm for interference emission.

Part 2: Industrial sector



Note

The following product and product family norms are applied for interference emissions.

EMC product family norms

EN 55011

published in official bulletin C44 from 19.02.92 (DIN VDE 0875-11):
1992-07 Interference suppression of electrical operational equipment and installations;

Limit values and measuring methods for interference suppression of high-frequency devices for industrial, scientific and medical applications (ISM) (CISPR 11 : amended in 1990)

EN 55022

published in official bulletin C241/2 from 16.09.95 (DIN VDE 0878-22):
05-1995 Limit values and measuring methods for interference suppression of instruments in information technology applications (CISPR 22 : 1993)

EMC product norms

prEN 61800-3

EMC product norm for electrical installations with variable speeds (currently under revision).

Interference immunity

EMC generic norm

EN 50082-2

published in official bulletin C241/2 from 16.09.95 (VDE 0839 Part 82-2):
1996-02 Electromagnetic compatibility (EMC) generic norm for interference immunity. Part 2: Industrial sector



Note

The following product and product family norms are applied for interference emissions.

EMC product norms

prEN 61800-3

EMC product norm for electrical installations with variable speeds (currently under revision).

EN 61131-2 mod

modified EMC product norm for PLC (programmable logic controllers), currently under revision.

7.4.3 EMC norm for domestic, business and commercial sectors

Interference emission **EMC generic norm**

EN 50 081-1

published in official bulletin C 90 from 10.04.92 (VDE 0839 Part 81-1):
1993-03 Electromagnetic compatibility (EMC) generic norm for interference emission.

Part 1: Domestic, business, commercial sectors and small enterprises

 **Note** The following product family norms are applied for interference emissions.

EMC product family norms

EN 60555-2

published in official bulletin C44 from 19.02.92 (VDE 0838 Part 2):
1987-06 Disturbances in power supply systems which are caused by domestic appliances and similar electrical devices.

Part 2: Limit values for harmonic currents
(nominal current <16 A)

 **Note** This norm will be withdrawn on 01.06.1998 and replaced by EN 61000-3-2: 1995.

EN 60555-3

published in official bulletin C44 from 19.02.92 (VDE 0838 Part 3):
1987-06 Disturbances in power supply systems which are caused by domestic appliances and similar electrical devices.

Part 3: Limit values for voltage fluctuations
(nominal current <16 A)

 **Note** This norm will be withdrawn on 01.06.1998 and replaced by EN 61000-3-2: 1995.

EN 61000 3-2

published in official bulletin C241/2 from 16.09.95 (VDE 0838 Part 2):
1996-03 Electromagnetic compatibility (EMC)

Part 3: Limit values, main section 2:
Limit values for harmonic currents
(device input current < 16 A per conductor)

EN 55011

published in official bulletin C44 from 19.02.92 (DIN VDE 0875-11):
07-1992 Interference suppression of electrical operational equipment and installations; Limit values and measuring methods for interference suppression of high-frequency devices for industrial, scientific and medical applications (ISM)

(CISPR 11: amended in 1990)

**EN 55014**

published in official bulletin C241/2 from 16.09.95
(DIN VDE 0875-14):

12-1993 Interference suppression of electrical operational equipment and installations; limit values and measuring methods for interference in devices for domestic use, electric tools and similar electrical devices

(CISPR 14: 1993)

EN 55022

published in official bulletin C241/2 from 16.09.95
(DIN VDE 0878-22):

05-1995 Limit values and measuring methods for interference suppression of instruments in information technology applications

(CISPR 22: 1993)

Interference immunity**EMC generic norm****EN 50082-1**

published in official bulletin C90 from 10.04.92 (VDE 0839 Part 82-1):
1993-03 Electromagnetic compatibility (EMC) generic norm for interference immunity.

Part 1: Domestic, business and commercial sectors

Your notes:



8 Recommendations of CEMEP

CEMEP

Comité Européen de Constructeurs
de Machines Electriques
et d'Electronique de Puissance

European Committee
of Manufacturers of Electrical
Machines and Power Electronics

CEMEP is the representative of the manufacturers of variable speed drives to the European Commission.

CEMEP vertritt die Interessen der Herstellerfirmen von drehzahlveränderbaren Antrieben bei der Europäischen Kommission.

General Secretariat

GIMELEC - 11, Rue Hamelin
75783 PARIS - Cedex 16
Tel.: [33].1.45.05.71.40
& [33].1.45.05.71.41
Fax: [33].1.45.05.16.79



ANIE
GAMBICA
GIMELEC
SETELI
ZVEI
Manufacturers

Italy
United Kingdom
France
Finland
Germany
Denmark

European Council Directives - CE marking and technical standardization Recommendation for application of Power Drive Systems (PDSs)

EG-Richtlinien - CE-Kennzeichnung und technische Normung Empfehlungen zum Einsatz von elektrischen Antriebssystemen (Power Drive System - PDS)

This recommendation has been established by CEMEP according to the decisions made during their meetings in Paris. [24-03-95 and 30/31-03-95]
See at the end, explanations of abbreviations and of purpose ———
Diese Empfehlungen wurden von CEMEP während ihrer Sitzungen in Paris am 24.03.1995 und 30./31.03.1995 erarbeitet und basieren auf den dort getroffenen Beschlüssen. Erklärung der Abkürzungen und der Zielsetzung auf den beiden letzten Seiten.

Machinery Directive

• Application

The Machinery Directive requires CE marking of the complete machine*¹. The PDS (including CDM/BDM*²) and motor are defined as components and not complete machines (MD article 4.2 and annex IIB). Therefore :

- No CE marking of the PDS or motor according to MD.
- Declaration of incorporation by the manufacturer of the PDS, respectively its components, not to be confused with EC Declaration of Conformity.
- Normative references :
Any safety relevant standard applied to components - [EN 60204-1][etc.]

Maschinenrichtlinie

• Anwendung

Die Maschinenrichtlinie erfordert die CE-Kennzeichnung von vollständigen Maschinen*¹. Das PDS mit seinen Untergruppen Basismodul - BDM und Antriebsumrichter = CDM*² ist als Komponente zu verstehen und nicht als vollständige Maschine (Maschinenrichtlinie, Artikel 4.2 und Anhang II B). Daraus folgt:

- Keine CE-Kennzeichnung des PDS oder des Motors (bezüglich Maschinenrichtlinie)
- Herstellererklärungen für das PDS bzw. seine Komponenten, welche nicht mit einer EG-Konformitätserklärung zu verwechseln sind.
- Normative Verweise:
Jede sicherheitsrelevante Norm für Komponenten, soweit anwendbar [z. B. EN 60 204-1]

Low Voltage Directive

• Application

The LVD applies to products*¹ operating in the voltage range 50V-1000V AC, or 75V-1500V DC. Declaration of conformity is the responsibility of the manufacturer of the PDS or of the CDM/BDM or of the machine, or of the installation according to the extend of their contribution to the electrical equipment.

- EC Declaration of conformity of equipment concerned - CE marking (mandatory : 1-1-1997).
- Normative references :
EN 60204-1 | EN 60529 | EN 60146-1-1 | EN 60146-1-3 | IEC 146-2 | IEC 146-3 | IEC 146-6 | prEN 50178

Niederspannungsrichtlinie

• Anwendung

Die Niederspannungsrichtlinie gilt für Produkte*¹, welche im Spannungsbereich 50 V - 1000 V AC bzw. 75 V - 1500 V DC arbeiten. Konformitätsbewertungsverfahren liegen sowohl in der Verantwortung der Hersteller von PDS bzw. CDM/BDM als auch der Maschinenhersteller oder des Anlagenerrichters, entsprechend ihrem Anteil an der Erweiterung der elektrischen Ausrüstung.

- EG-Konformitätserklärung für die betroffenen elektrischen Ausrüstungen und CE-Kennzeichnung (Pflicht ab dem 01.01.1997).
- Normative Verweise:
[EN 60204-1] | [EN 60529] | [EN 60146-1-1] | [EN 60146-1-3] | [IEC 146-2] | [IEC 146-3] | [IEC 146-6] | [prEN 50178]

*¹ Except for items excluded from this Directive.

*² See figure page 2, and glossary on last page.

*¹ außer speziellen, durch die Richtlinie festgelegten Ausnahmen

*² siehe auch Bild auf Seite 2

Application of the EMC Directive to PDSs
Anwendung der EMV-Richtlinie auf elektrische Antriebe (PDS)

The figure below and table on the following page are only to be considered when applying the EMC Directive
Das folgende Bild und die Tabelle auf der folgenden Seite gelten nur im Hinblick auf die EMV-Richtlinie

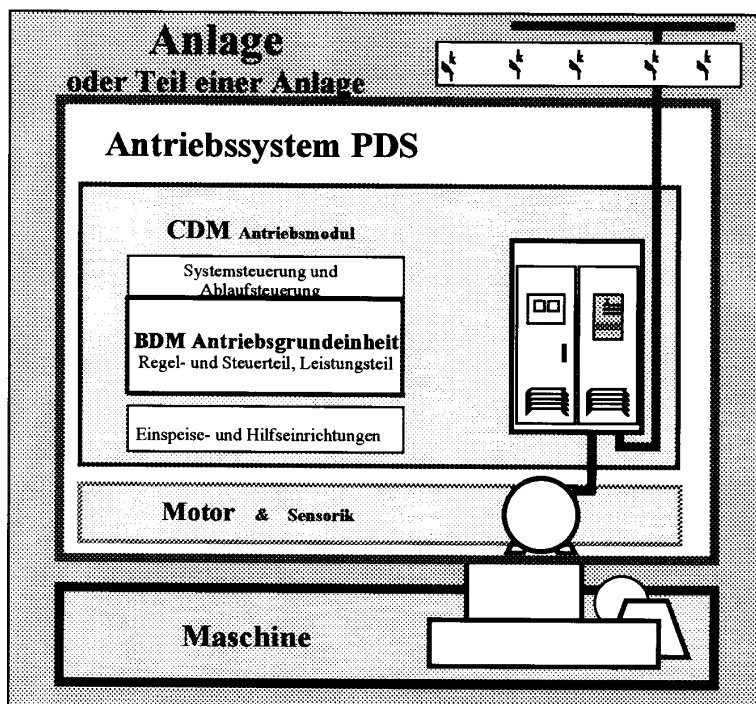
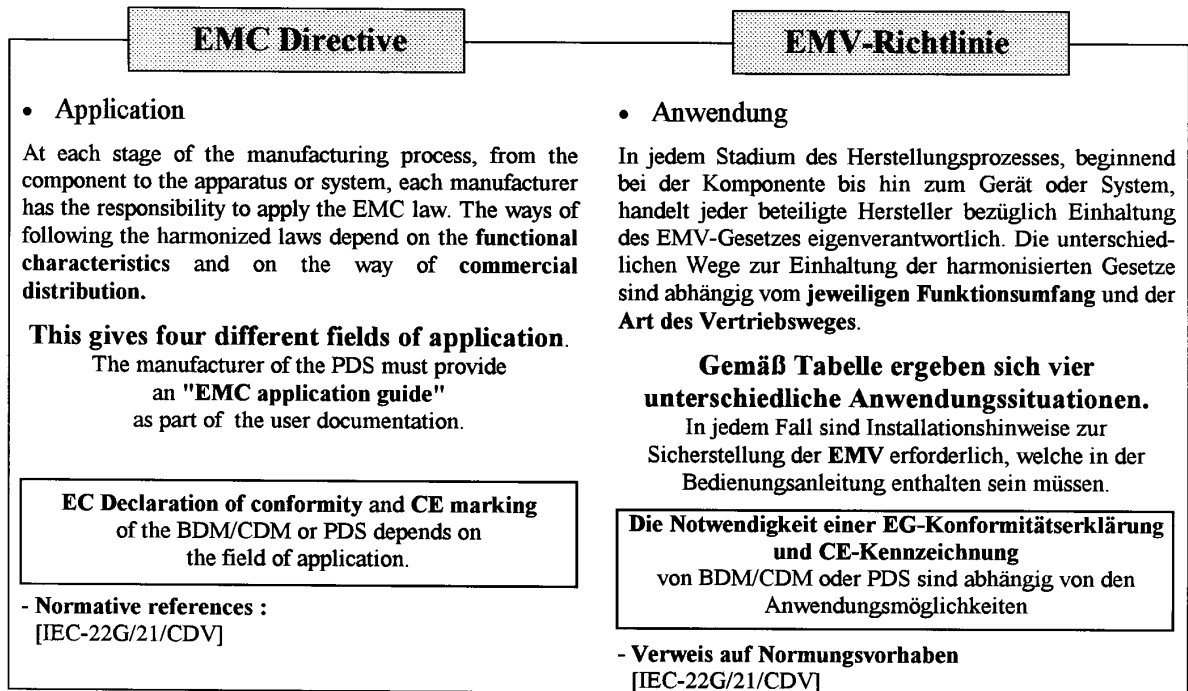

Beachte Festlegungen und Abkürzungen auf der letzten Seite

Ein elektrischer Antrieb (PDS) ist Teil einer Maschinen (eines Systemes oder Prozesses).

Die Nachweisführung zur Einhaltung der EMV-Richtlinie hängt vom Funktionsumfang und der Art des Vertriebsweges ab

**Die Gültigkeitsfelder der EMV-Richtlinie (89/336) und ihre Anwendung auf elektrische Antriebe**

Die **CE-Kennzeichnung** läßt die Einhaltung der Schutzanforderungen der EMV-Richtlinie vermuten und stützt sich auf die **EG-Konformitätserklärung**.

Die Angaben der Abschnittsnummern beziehen sich auf den „Leitfaden zur Anwendung der EMV-Richtlinie 89/336/EEC, Brüssel, 25. & 26. Oktober 1993“.

Gültigkeitsfeld	Beschreibung
<p>-1- Komponenten zum direkten Einsatz beim Verwender [Abschnitt 4.7 (Absatz 4) und Abschnitt 4.7b]</p> <p>PDS oder CDM oder BDM, welche allgemein erhältlich sind.</p>	<p>Direktes Inverkehrbringen im unbehinderten, grenzüberschreitenden Warenverkehr - EG-Konformitätserklärung und CE-Kennzeichnung sind erforderlich.</p> <p>Der Hersteller des PDS (oder CDM/BDM) ist EMV-verantwortlich für diese Produkte unter festgelegten Randbedingungen. Zusätzlich notwendige EMV-Maßnahmen außerhalb des Gerätes sind in einfacher Weise beschrieben und auch von technischen Laien durchführbar. Die endgültige EMV liegt im Verantwortungsbereich des Verwenders durch Einhaltung der Herstellerempfehlungen und Anwendungsbeschreibungen.</p>
<p>-2- Komponenten zum Einsatz durch fachkundige Weiterverwender (z.B. Maschinenbauer) [Abschnitt 4.7 (2. und 3. Absatz) und Abschnitt 4.7a]</p> <p>PDS oder CDM/BDM, welche nur eingeschränkt erhältlich sind und als Komponente in eine Maschine, ein System oder eine Anlage eingebaut werden.</p>	<p>Nur für den Fachmann gedacht, der eine sachgerechte Installation durchführen kann. Nicht selbständig betreibbar im Sinne der Anwendung beim Endkunden - Keine EG-Konformitätserklärung und keine CE-Kennzeichnung erforderlich. - Anwendung des Normentwurfes 22G/21/CDV Der Komponentenhersteller (von PDS, CDM oder BDM) ist für die Bereitstellung von Installationsrichtlinien verantwortlich. Die EMV der endgültigen Anwendung liegt im Verantwortungsbereich des Maschinenbauers, System- und Anlagenerrichters.</p>
<p>-3- Anlagen [Abschnitt 4.6]</p> <p>Ein oder mehrere PDS, auch unterschiedlicher Klassen - allgemein oder eingeschränkt erhältlich - welche gemeinsam in eine Anlage am Errichtungsort installiert werden.</p>	<p>Nicht zum Inverkehrbringen als eigene Funktionseinheit geeignet. Anlage, welche daraus abgeleitet wird, muß für sich selbst der EMV-Richtlinie genügen. - Keine EG-Konformitätserklärung keine CE-Kennzeichnung erforderlich - Anwendung des Normentwurfes 22G/21/CDV. Endgültige EMV liegt im Verantwortungsbereich des Anlagenerrichters (z. B. durch EMV-Planung). Schutzanforderungen der EMV-Richtlinie sind einzuhalten und beziehen sich auf die Wechselwirkungen der Anlage mit ihrer Umgebung</p>
<p>-4- Geräte/Systeme [Abschnitt 4.4 und 4.5]</p> <p>Ein oder mehrere PDS, CDM oder BDM, welche gemeinsam als Gerät/System allgemein erhältlich sind.</p>	<p>Besitzt eine für den Endnutzer bestimmte Funktion und ist als spezielles Gerät/System in Verkehr gebracht - EG-Konformitätserklärung und CE-Kennzeichnung (des Gerätes oder Systems) sind erforderlich. Endgültige EMV liegt im Verantwortungsbereich des Geräte-/Systemherstellers.</p>

Beispiele zur Anwendung der verschiedenen Gültigkeitsfelder:

- BDM, welches an unterschiedlichen Orten uneingeschränkt zum Einsatz kommt** (beispielsweise in Wohngebieten oder aber allgemein erhältlich). Der Hersteller ist zur Einhaltung einer angepaßten EMV verantwortlich. Diese EMV muß sichergestellt sein, wenn ein unbekannter Weiterverwender (z. B. ein technischer Laie) das BDM unter den vorgesehenen Randbedingungen in Betrieb nimmt (Motto: Auspacken und Einschalten).
- CDM/BDM oder PDS für allgemeinen Verwendungszweck**, zum Einbau in eine Maschine oder in sonstiger Industrieausrüstung. Diese Komponenten werden an fachkundigen Weiterverwender oder Maschinenbauer oder Anlagenerrichter verkauft. Installationsrichtlinien sind in der Bedienungsanleitung anzugeben. Der gegenseitige Austausch von technischen Informationen zu Störaussendung und Störfestigkeit ermöglicht die vorteilhafteste Lösung zu angepaßter EMV.
- PDS als Industrieanlage**
Die Randbedingungen zum Einsatz werden zum Zeitpunkt der Bestellung festgelegt. Infolgedessen ist ein Austausch von technischen Informationen zwischen Lieferant und Kunde möglich. Der Lieferumfang kann aus unterschiedlichen Handlungsgütern bestehen (z. B. PDS, mechanische Komponenten, Prozeßsteuereinheiten usw.). Die Zusammenstellung von Einzelsystemen in der Anlage muß auf technisch wirtschaftlicher Basis derart erfolgen, daß angepaßte EMV-Maßnahmen getroffen werden können, wie Blindleistungskompensationen als typisches Beispiel.
(Anwendungsbeispiele: Walzwerke, Papierindustrie, Eisenbahnen usw.)
- Geräte mit eingebautem PDS** wie z. B. Staubsauger, Haartrockner, andere Haushaltsgeräte. Selbständig betreibbare Geräte mit Eigenfunktion.



**Zusammenfassung der Herstellerverantwortlichkeiten
bei der Anwendung der zutreffenden EG-Richtlinien auf elektrische Antriebe**

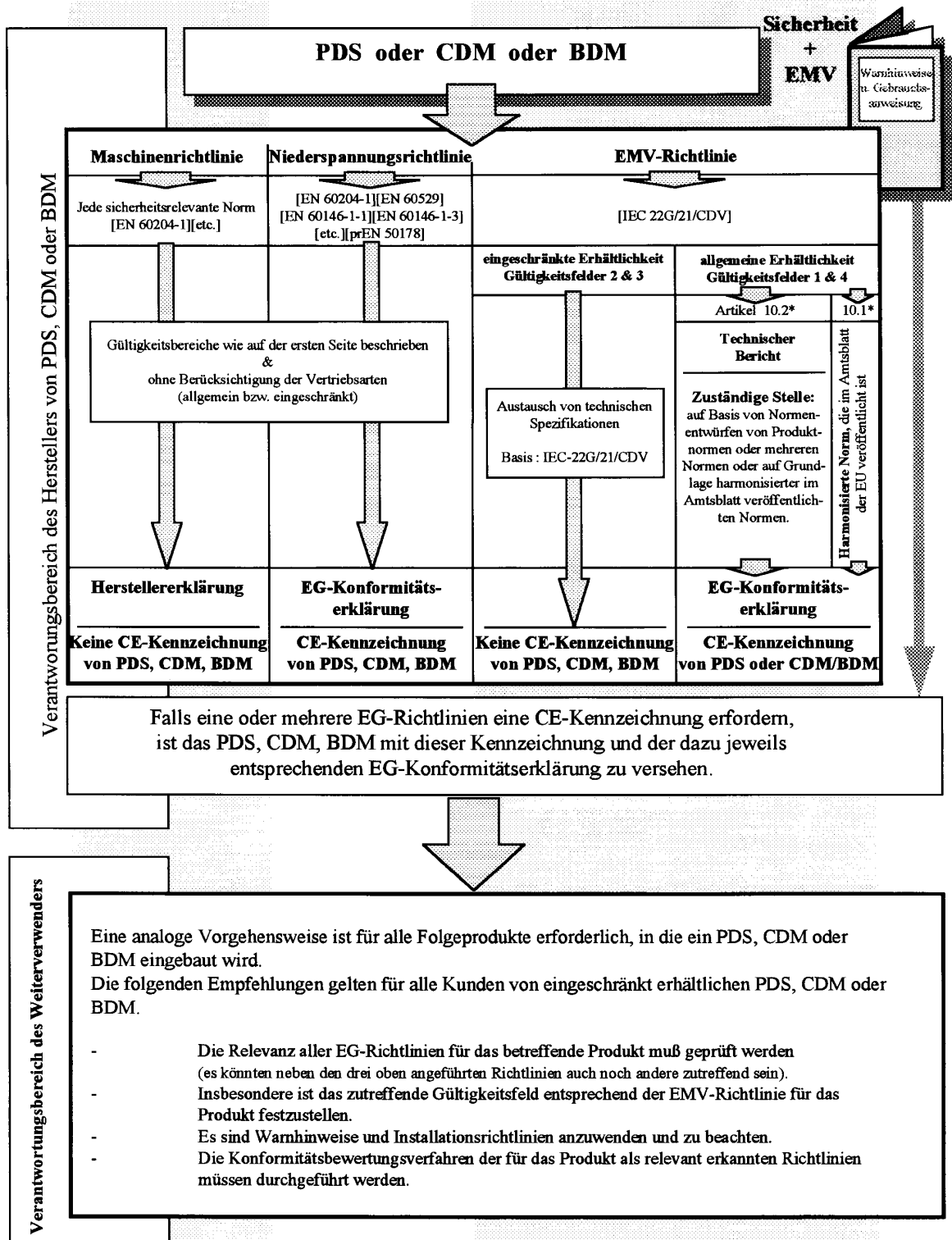

* : Abschnitte aus der EMV-Richtlinie

**EMC Rules and Routes****Wege und Regeln zu EMV****CE marking - for fields 1 and 4**

- **Conformity to an Harmonised Standard, published in the Official Journal of the European Union, if it exists.**
At 1-1-1996 only the Generic Standards exist:
EN 50081-1 & EN 50081-2
EN 50082-1 & EN 50082-2
An EMC product standard for PDSs should be available in the near future.
- **Or Technical Construction File (TCF) + Competent Body Certificate or Technical report.**

Certificate should be delivered, only with reference to an approved draft of dedicated product standard (example: if approved, IEC-22G/21/CDV), or to an approved set of standards, or to principles and basis of an Harmonized Standard published in the OJ of EU.

No CE marking - for fields 2 and 3

- Manufacturer's EMC instructions are required for application of the PDS or CDM/BDM.

In any case, the basic concepts are in the IEC draft 22G/21/CDV

Voraussetzung zur CE-Kennzeichnung für Produkte in den Gültigkeitsfeldern 1 & 4

- **Übereinstimmung mit einer harmonisierten Norm, die im Amtsblatt der EU veröffentlicht ist.**
Am 01.01.1996 gibt es hierzu voraussichtlich nur die Fachgrundnormen
EN 50081-1 & EN 50081-2
EN 50082-1 & EN 50082-2
So bald wie möglich sollte eine EMV-Produktnorm für PDS verfügbar sein.
- **oder Technischer Bericht (Technical Construction File [TCF] + Bescheinigung einer zuständigen Stelle.**

Die Bescheinigung sollte sich auf anerkannte und passende Produktnormen oder -entwürfe (z. B. IEC 22G/21/CDV) oder auf mehrere anerkannte Normen oder auf im Amtsblatt der EU veröffentlichten Normen abstützen.

Keine CE-Kennzeichnung für die Gültigkeitsfelder 2 und 3

- Herstellerempfehlungen und -informationen zu EMV sind beim Einsatz von PDS, CDM/BDM erforderlich.

In jedem Fall sind die grundsätzlichen Vorgehensweisen im IEC-Entwurf 22G/21/CDV vorgegeben.

EMC CONCLUSION

The EMC Directive gives a common statement in the whole E.U. of essential requirements for electrical equipment (article 4):

- does not emit unreasonably
- be reasonably immune

which has been the basis for the responsible use of electricity.

The EMC Directive gives a common approach to show sufficient presumption of compliance in simple cases (article 10), these are fields 4 and 1. Moreover it allows the creation of sufficient technical and economical solutions in complex cases such as fields 2 and 3.

The basis of the state of the art, for manufacturing and applying PDSs is summarized in IEC-22G/21/CDV. Reference to this draft is recommended by CEMEP until further steps are achieved (ACDV, DIS etc.). This common reference is one way to deliver an appropriate solution for use of PDSs in the frame of the EMC Directive.

SCHLUSSFOLGERUNGEN ZU EMV

Die EMV-Richtlinie gibt folgende allgemeingültigen Schutzanforderungen für elektrische/elektronische Geräte in der EU vor:

- keine unzulässig hohe Störaussendung
- ausreichende Störfestigkeit

Beides ist Grundlage für einen sinnvollen Umgang mit elektrischer Energie.

Die EMV-Richtlinie (sowie der zugehörige Leitfaden) enthält einen allgemein gültigen Ansatz, nach dem ihre Einhaltung in einfachen Fällen (Artikel 10) vermutet werden kann - dies entspricht den Gültigkeitsfeldern 1&4.

Darüber hinaus bietet sie ausreichenden Freiraum zur Schaffung von technisch wirtschaftlich optimalen Gesamtlösungen in schwierigen Fällen, entsprechend den Gültigkeitsfeldern 2 & 3. Der Stand der Technik bei der Anwendung von elektrischen Antrieben ist im Normentwurf IEC 22G/21/CDV zusammengefaßt. Der Bezug zu diesem Entwurf wird von CEMEP solange empfohlen, bis weitere Fortschritte im Normungsprozeß (ACDV, DIS usw.) erzielt werden. Diese allgemeine Bezugsbasis ist ein möglicher Weg, um für die elektrische Antriebstechnik eine angepaßte Lösung im Rahmen der EMV-Richtlinie zu erhalten.

For purchasers and users of PDSs.

The purpose of this document is to describe how to achieve compliance with the Essential Requirements of the relevant Directives, when applying power drive systems. The responsibilities within the chain of distribution are pointed out to make sure that this matter is handled according to the complexity of the field of application and the correct use of codes of practice.

Für Käufer und Anwender von PDS

Das vorliegende Papier dient zur Beschreibung, wie beim Einsatz von elektrischer Antriebstechnik die Übereinstimmung mit den Schutzanforderungen der zutreffenden EG-Richtlinien nachgewiesen wird. Insbesondere wird die Lage der Verantwortlichkeiten innerhalb einer Vertriebskette beschrieben, um sicherzustellen, daß die gesamte Thematik im Einklang zur Variationsbreite der Einsatzmöglichkeiten und der richtigen Anwendung von praktischen Regeln gehandhabt werden kann.



Glossary - Glossar

Clauses numbers [.] refer to European Commission document "Guidelines on the Application of Council Directive 89/336/EEC" Brussels, 25 & 26 Oct. 1993.		Clauses numbers [.] refer to European Commission document "Guidelines on the Application of Council Directive 89/336/EEC" Brussels, 25 & 26 Oct. 1993.	
EU	European Union	EU	Europäische Union
OJ	Official Journal (of the EU)	OJ	Amtsblatt der Europäischen Union
MD	Machinery Directive	MD	Maschinenrichtlinie
LVD	Low Voltage Directive	LVD	Niederspannungsrichtlinie
EMCD	Electromagnetic Compatibility Directive	EMCD	EMV-Richtlinie
Restricted	Restricted distribution : the mode of sales distribution in which the manufacturer restricts the supply of equipment to suppliers, customers or users who separately or jointly have technical competence in the EMC requirements of the application of drives.	Restricted	Eingeschränkte Erhältlichkeit: Bezugsmöglichkeiten von Komponenten der elektrischen Antriebstechnik nur für fachkundige Weiterverwender (Elektrofachkräfte) mit EMV-Basiskenntnissen.
Unrestricted	Unrestricted distribution : the mode of sales distribution in which the supply of equipment is not dependent on the competence of the customer or user for the application of drives.	Unrestricted Distribution	Allgemeine Erhältlichkeit, bei der jeder Käufer (also auch ohne Kenntnis der elektrischen Antriebstechnik) Ausrüstungsgegenstände beziehen kann.
Apparatus (clause 4.4)	A finished product with an intrinsic function intended for the final user and intended to be placed on the market as a single commercial unit.	Apparatus (article 4.4)	Gerät: Endprodukt mit einer ihm eigenen Funktion, das für den Endbenutzer bestimmt ist und als eine einzige Handelsware in Verkehr gebracht werden soll.
System (clause 4.5)	Several items of apparatus combined to fulfil a specific objective and intended to be placed on the market as a single functional unit.	System (article 4.5)	System: mehrere zu einem bestimmten Zweck miteinander verbundene Geräte, die als eine einzige Funktionseinheit in Verkehr gebracht werden sollen.
Installation (clause 4.6)	Several combined items of apparatus or systems put together at a given place to fulfil a specific objective but not intended to be placed on the market as a single functional unit.	Installation (article 4.6)	Anlage: mehrere zu einem bestimmten Zweck und an einem bestimmten Ort miteinander verbundene Geräte oder Systeme, die jedoch nicht als eine einzige Funktionseinheit in Verkehr gebracht werden sollen.
Complex component sold directly to final consumer (clause 4.7, 4th § and clause 4.7 b)	Component of a complex nature which is placed directly on the market and intended for the final user.	Complex component sold directly to final consumer (clause 4.7, 4th § and clause 4.7 b)	komplexe Komponente oder Unterbaugruppe, welche allgemein erhältlich ist und für den Endbenutzer bestimmt ist.
Complex component only for professional assemblers (clause 4.7, 2nd and 3rd §, and clause 4.7 a)	An item which is used in the composition of an apparatus and which is not itself an apparatus with an intrinsic function and which is not intended for the final user.	Complex component only for professional assemblers (clause 4.7, 2nd and 3rd §, and clause 4.7 a)	komplexe Komponente oder Unterbaugruppe, welche nur eingeschränkt erhältlich ist, selbst kein Gerät im Sinne der Definition darstellt, somit nicht für die Verwendung durch einen Endbenutzer bestimmt ist, sondern in ein Gerät eingebaut ist.
BDM	Basic Drive Module	BDM	Antriebsgrundeinheit (Regel- und Steuerteil, Leistungsteil)
CDM	Complete Drive Module	CDM	Antriebsmodul
PDS	Power Drive System	PDS	Elektrisches Antriebssystem

ANIE - UCIREV	: ABB Industria S.p.a. - ANSALDO Industria S.p.a. - BMB Elettronica Industriale S.p.a. - C.E.A.I. Elettronica S.p.a. - CONTROL TECHNIQUES S.p.a. - ELETTRONICA SANTERNO - EQUIPAGGIAMENTI Elettronici Industriali s.r.l. - GHISALBA S.p.a. - ISE Industria Servomeccanismi Elettronici S.p.a. - S.C.S. Static Control System s.r.l. - SIEI Peterlongo S.p.a. - SILECTRON Sistemi s.r.l.
GAMBICA	: AEG (UK) Ltd Engineering Division - ALLEN BRADLEY IAP Ltd - BRUSH Industrial Controls Ltd - CECELEC Industrial Controls Ltd - CECELEC Projects Ltd - DANFOSS Ltd - EATON Ltd Westinghouse & Cutler-Hammer Products - EUROTHERM Drives Ltd - FENNER Electronic Controls Ltd - HILL GRAHAM Controls Ltd - KLOCKNER-MOELLER Ltd - MITSUBISHI Electric (UK) Ltd - R-R Industrial Controls Ltd - SIEMENS plc - TELEMECANIQUE Ltd - THORN Automation Ltd.
GIMELEC	: ABB Industry - AOIP - CECELEC - DANFOSS SARL - EUROTHERM - LEROY SOMMER - METAL DEPLOYE - SCHNEIDER ELECTRIC - SEW-USOCOME.
SETELI	: ABB.
ZVEI	: ABB Industrietechnik AG - Eberhard Bauer GmbH & Co. - BAUMÜLLER Nürnberg GmbH - BERGES electronic GmbH - ROBERT BOSCH GMBH - DANFOSS Antriebs- und Regeltechnik GmbH - Flender ATB-Loher Systemtechnik GmbH - GECELEC AEG ANLAGEN UND ANTRIEBSSYSTEME GMBH - SIEMENS Aktiengesellschaft - Stromag AG - VEM motors GmbH.
Other / Autres	: DANFOSS A/S (Denmark).

9 Order numbers

Designation	Order no.
Typical configuration with VM 50/B - TC1	Refer to page 5-2
Typical configuration with VM 60/EB - TA	Refer to page 5-3
Typical configuration with VM 20...K:	Refer to page 5-4
Mains filter: for synchronisation line VM../R-T: 420 V/ 6 A	1070 913 529
for mains line:	
440 V/ 16 A Cl.A (industrial sector)	1070 918 475
440 V/ 25 A Cl.A (industrial sector)	1070 918 476
440 V/ 36 A Cl.A (industrial sector)	1070 918 477
440 V/ 50 A Cl.A (industrial sector)	1070 918 478
440 V/ 80 A Cl.A (industrial sector)	1070 918 479
Ferrite annular cores for motor lines Ø 28 mm x 20 mm	1070 918 505 ¹⁾
Filter for holding brake of motors	1070 917 448

¹⁾ contains 20 ferrite annular cores in packaging for transport

Your notes:

A Appendix

A.1 Safety notes

A.1.1 Dansk

Farehenvisninger i håndbogen.

Følg sikkerhedshenvisningerne i håndbogen (FARE, ADVARSEL) om farer for liv og helbred og forebyggelse af materielle skader, såvel som de fremhævede informationer om produktet (Bemærk).

Alle sikkerhedshenvisninger har et fortløbende nummer med henvisning til kapitlerne, eksempelvis 1.1. I tillægget finder De de tilhørende oversættelser af disse sikkerhedshenvisninger på alle sprog indenfor EU.

! FARE !**1.1**

Vedligeholdelse og installering af komponenterne må kun udføres af elektrofagfolk (VDE 1000-10) under overholdelse af de ulykkesforebyggende forskrifter og installationsforskrifterne (EN 60204-del1, prEN 50178).

**! FARE !****1.2**

En fejlfri og sikker brug af produktet, forudsætter formålstjenlig transport, korrekt oplagring, opstilling og montering såvel som en omhyggelig betjening.

**ADVERSEL !****1.3**

Drevomformer indeholder konstruktionsdele, som har risiko for elektrostatisk ladning, og som gennem usagkyndig behandling let kan ødelægges.

! FARE !**1.4**

Indbyggede elektriske komponenter må pga. den mulige sundhedsfare ikke destrueres.

**! FARE !****3.1**

Farlige chokstrømme p.g.a. utilstrækkelige preltrådsforbindelser.
Preltrådsforbindelser må ikke påvirkes mekanisk, kemisk eller elektrokemisk.
Forbindelsen skal være permanent.



! FARE !

3.2



Netfiltre indeholder kondensatorer og afladningsmodstande, som også efter frakobling af
netspændingen indeholder livsfarlige spændinger.

Berør først effektklemmer med værktøj efter min. 10 sek.!

A.1.2 Deutsch

Gefahrenhinweise im Handbuch

Beachten Sie die im Handbuch enthaltenen Sicherheitshinweise ('GEFAHR', 'ACHTUNG') zu Gefahren für Leben und Gesundheit und zur Vermeidung von Sachschäden, sowie die hervorgehobenen Informationen zum Produkt ('Hinweis').

Alle Sicherheitshinweise haben eine fortlaufende Nummer mit Bezug zu den Kapiteln, z.B. 1.1 . Im Anhang finden Sie die zugehörigen Übersetzungen dieser Sicherheitshinweise in allen Amtssprachen der EU.

! GEFAHR !	1.1
Warten und Installieren der Komponenten nur durch Elektrofachkräfte (VDE 1000-10) unter Beachtung der Unfallverhütungsvorschriften (UVV VBG4, VDE 100, VDE 105) und Installationsvorschriften (EN 60204-Teil1, prEN 50178).	



! GEFAHR !	1.2
Der einwandfreie und sichere Betrieb des Produktes setzt sachgemäßen Transport, sachgerechte Lagerung, Aufstellung und Montage sowie sorgfältige Bedienung voraus.	



ACHTUNG !	1.3
Antriebsumrichter enthalten elektrostatisch gefährdete Bauelemente, die durch unsachgemäße Behandlung leicht zerstört werden können.	

! GEFAHR !	1.4
Eingebaute elektrische Komponenten dürfen wegen möglicher Gesundheitsgefährdung nicht zerstört werden.	



! GEFAHR !	3.1
Gefährliche Körperströme durch unzureichende Schutzleiterverbindungen. Schutzleiterverbindungen dürfen nicht durch mechanische, chemische oder elektrochemische Einflüsse beeinträchtigt werden. Die Verbindung muß dauerhaft fest sein.	



! GEFAHR !	3.2
Netzfilter enthalten Kondensatoren und Entladewiderstände, die auch nach Abschalten der Netzspannung lebensgefährliche Spannungen enthalten. Leistungsklemmen erst nach min. 10 sek mit einem Werkzeug berühren!	



A.1.3 Ελληνικά

Υποδείξεις για πηγές κινδύνου στο Εγχειρίδιο

Προσέξτε τις υποδείξεις ασφαλείας στο Εγχειρίδιο („ΚΙΝΔΥΝΟΣ”, „ΠΡΟΣΟΧΗ”) για την πρόληψη κινδύνων για τη ζωή και την υγεία, καθώς και για την αποφυγή υλικών ζημιών, και τις πληροφορίες για το προϊόν (“Υπόδειξη”).

Όλες οι υποδείξεις ασφαλείας έχουν έναν αύξοντα αριθμό που αντιστοιχεί στα επιμέρους κεφάλαια, π.χ. 1.1. Στο παράρτημα βρίσκετε τη μετάφραση αυτών των υποδείξεων ασφαλείας σε όλες τις επίσημες γλώσσες της Ευρωπαϊκής Ένωσης.

	<p style="text-align: center;">! ΚΙΝΔΥΝΟΣ !</p> <p style="text-align: right;">1.1</p> <p>Η συντήρηση και η εγκατάσταση των στοιχείων πρέπει να γίνεται μόνο από ειδικευμένους ηλεκτρολόγους (VDE 1000-10) με βάση τους κανονισμούς προστασίας από ατυχήματα και τους κανονισμούς εγκατάστασης (EN 60204-Μέρος1, prEN 50178).</p>
	<p style="text-align: center;">! ΚΙΝΔΥΝΟΣ !</p> <p style="text-align: right;">1.2</p> <p>Η απρόσκοπτη και ασφαλής λειτουργία του προϊόντος προϋποθέτει σωστή μεταφορά, κατάλληλη αποθήκευση, τοποθέτηση και συναρμολόγηση καθώς και προσεκτικό χειρισμό</p>
	<p style="text-align: center;">ΚΙΝΔΥΝΟΣ !</p> <p style="text-align: right;">1.3</p> <p>Οι προωθητικοί μεταλλάκτες περιέχουν ηλεκτροστατικά επισφαλή στοιχεία κατασκευής, που μπορούν εύκολα να καταστραφούν από απρόσεκτο χειρισμό.</p>
	<p style="text-align: center;">! ΚΙΝΔΥΝΟΣ !</p> <p style="text-align: right;">1.4</p> <p>Τα ενσωματωμένα ηλεκτρικά στοιχεία δεν επιτρέπεται να καταστρέφονται, λόγω πιθανών κινδύνων για την υγεία.</p>
	<p style="text-align: center;">! ΚΙΝΔΥΝΟΣ !</p> <p style="text-align: right;">3.1</p> <p>Επικίνδυνα ρεύματα σώματος από ανεπαρκείς συνδέσεις προστατευτικών αγωγών. Οι συνδέσεις προστατευτικών αγωγών δεν επιτρέπεται να καταπονούνται από μηχανικές, χημικές ή ηλεκτροχημικές επιδράσεις. Η σύνδεση πρέπει να είναι μόνιμα στερεή.</p>

! ΚΙΝΔΥΝΟΣ !**3.2**

Τα φίλτρα δικτύου περιλαμβάνουν πυκνωτές και αντιστάσεις εκφόρτισης, που βρίσκονται σε επικίνδυνη ηλ. τάση ακόμη και μετά την διακοπή της τάσης του δικτύου.

Ακουμπήστε μόνο μετά από 10 λεπτά τους ακροδέκτες μεγάλης ισχύος με ένα εργαλείο!



A.1.4 Español

Indicaciones de peligro incluidas en el manual

Observe las indicaciones de seguridad incluidas en el manual (PELIGRO, ATENCION) referentes a peligros para la vida y la salud y para prevenir daños materiales, así como las informaciones destacadas sobre el producto (Nota).

Todas las indicaciones de seguridad tienen un número consecutivo con referencia a los capítulos, p. ej. 1.1. En el anexo usted encontrará las traducciones respectivas en todos los idiomas oficiales de la UE.



¡PELIGRO!

1.1

El mantenimiento y la instalación de los componentes debe realizarlo únicamente personal especializado en electrónica (VDE 1000–10) y deberán tenerse en cuenta las prescripciones de prevención de accidentes y las prescripciones de instalación (EN 60204-parte1, prEN 50178).



¡PELIGRO!

1.2

Para que el producto funcione perfectamente y de forma segura es imprescindible que haya sido transportado, almacenado, instalado y montado de manera adecuada y que se maneje cuidadosamente.

¡ATENCIÓN!

1.3

Los convertidores estáticos contienen componentes susceptibles a destrucción por carga electrostática y pueden destruirse fácilmente en caso de manipulación inadecuada.



¡PELIGRO!

1.4

Los componentes eléctricos no deben destruirse, ya que puede ser perjudicial para la salud.



¡PELIGRO!

3.1

Si las uniones de los conductores de protección son insuficientes se pueden producir corrientes peligrosas.
Las uniones de los conductores de protección no deben verse afectadas por influjos mecánicos, químicos o electroquímicos. La unión debe estar bien apretada en todo momento.

¡PELIGRO!**3.2**

Los filtros de la red contienen condensadores y resistencias de descarga que también contienen tensiones peligrosas después de desconectar la tensión eléctrica.

No toque los bornes de potencia con un instrumento hasta después de 10 s como mínimo.







A.1.5 Français

Indications de danger dans le manuel

Tenez compte des consignes de sécurité contenues dans le manuel (DANGER, ATTENTION) relatives aux dangers pour la vie et la santé et pour éviter les dommages matériels, ainsi que les informations particulières sur le produit (Remarque).

Toutes les consignes de sécurité ont une numérotation en continu en rapport avec les chapitres, par exemple 1.1. En annexe vous trouverez les traductions correspondantes dans toutes les langues officielles de la CEE.

	<p style="text-align: center;">! DANGER ! 1.1</p> <p style="text-align: center;">Entretien et installation des composants uniquement par des spécialistes en électricité (VDE 1000-10), conformément aux prescriptions de prévention des accidents et aux consignes d'installation (NE 60204 partie 1, NE pr 50178).</p>
	<p style="text-align: center;">! DANGER ! 1.2</p> <p style="text-align: center;">Le fonctionnement parfait et sûr du produit est conditionné par un transport professionnel, un stockage, une implantation et un montage corrects ainsi qu'une manipulation soignée.</p>
	<p style="text-align: center;">ATTENTION ! 1.3</p> <p style="text-align: center;">Les convertisseurs d'entraînement contiennent des éléments présentant une sensibilité électrostatique, qui peuvent être aisément endommagés en cas de manipulation inappropriée.</p>
	<p style="text-align: center;">! DANGER ! 1.4</p> <p style="text-align: center;">Les composants électriques installés ne doivent pas être détruits en raison de l'éventuel danger pour la santé.</p>
	<p style="text-align: center;">! DANGER ! 3.1</p> <p style="text-align: center;">Courants dangereux en cas d'insuffisance des connexions de circuits de protection. Les connexions des circuits de protection ne doivent pas être affectées par des admissions mécaniques, chimiques ou électrochimiques. La connexion doit rester fixée durablement.</p>
	<p style="text-align: center;">! DANGER ! 3.2</p> <p style="text-align: center;">Les filtres réseaux contiennent des condensateurs et des résistances de décharge qui sont toujours soumis à des tensions dangereuses après la mise hors circuit de la tension du réseau. Attendre au moins 10 sec. avant de toucher les bornes de puissance avec un outil de travail !</p>

A.1.6 Italiano

Indicazioni di pericolo nel manuale

Osservare le indicazioni di sicurezza (PERICOLO, ATTENZIONE) contenute nel manuale relative ai pericoli anche mortali, alla salute e alle misure necessarie per evitare danni all'apparecchio, nonché le informazioni sul prodotto (Nota).

Tutte le indicazioni di sicurezza sono numerate in ordine crescente con riferimento al capitolo, come ad es. 1.1. Nell'appendice è riportata la traduzione corrispondente di tali norme di sicurezza, in tutte le lingue ufficiali dell'Unione Europea.

! PERICOLO !	1.1
La manutenzione e l'installazione delle componenti deve essere effettuata solo da elettricisti specializzati (VDE 1000-10) e nel rispetto delle prescrizioni contro gli infortuni e per le installazioni (EN 60204-parte 1, prEN 50178).	



! PERICOLO !	1.2
Questo prodotto può funzionare in modo sicuro e a regola d'arte solamente se il suo trasporto, immagazzinaggio, installazione e montaggio sono avvenuti in modo appropriato e col presupposto di un corretto azionamento.	



ATTENZIONE !	1.3
Il convertitore di frequenza del motore contiene elementi sensibili alle cariche elettrostatiche, che possono venire distrutti in caso di interventi non professionali.	

! PERICOLO !	1.4
Le componenti elettriche non devono essere distrutte, prima dello smaltimento, per evitare possibili danni alla salute .	



! PERICOLO !	3.1
Scosse elettriche pericolose in caso di collegamenti di protezione insufficienti. I conduttori di protezione non devono essere pregiudicati da influenze meccaniche, chimiche o elettriche. I collegamenti devono essere fissi e permanenti.	



! PERICOLO !

3.2



I filtri di rete contengono condensatori e resistenze di scarico che mantengono tensioni mortali anche dopo il disinserimento della tensione.
Toccare i morsetti di potenza con un utensile solo dopo aver lasciato trascorrere almeno 10 sec !

A.1.7 Nederlands**Waarschuingswenken in het handboek**

Neemt u de in het handboek vermelde veiligheidswenken (GEVAAR, ATTENTIE) voor de gevaren van leven en gezondheid en ter voorkoming van schade, en de geaccentueerde informatie over het produkt (Tip) in acht. Alle veiligheidswenken hebben een doorlopend nummer met betrekking op de hoofdstukken, b.v. 1.1. In het aanhangsel vindt u de bijbehorende vertalingen van deze veiligheidswenken in alle officiële talen van de EU.

! GEVAAR !**1.1**

Onderhoud en installatie van de componenten enkel door een elektrotechnisch vakman (VDE 1000-10), met inachtneming van de voorschriften ter voorkoming van ongevallen en de installatievoorschriften (EN 60204-deel 1, prEN 50178), laten uitvoeren.

**! GEVAAR !****1.2**

Het goed en veilig functioneren van het produkt stelt deskundig transport, goede opslag, opstelling en montage en zorgvuldige bediening voorop.

**ATTENTIE !****1.3**

Aandrijfomzetters bevatten elektrostatisch gevaar lopende bouwelementen die door een ondeskundige behandeling gemakkelijk vernietigd kunnen worden.

! GEVAAR !**1.4**

Ingebouwde elektrische componenten mogen niet vernietigd worden omdat de gezondheid in gevaar gebracht zou kunnen worden.

**! GEVAAR !****3.1**

Gevaarlijke lichaamsstromen door onvoldoende veiligheidsaarddraadverbindingen. De veiligheidsaarddraadverbindingen mogen geen mechanische, chemische of elektrochemische invloeden ondergaan. De verbinding moet duurzaam zijn.

**! GEVAAR !****3.2**

Netfilters bevatten condensators en ontladingsweerstand die ook na uitschakelen van de netspanning levensgevaarlijke spanningen behouden.
Vermogensklemmen pas na min. 10 sec. met een stuk gereedschap aanraken!



A.1.8 Português

Notas de perigo no manual

Considere as notas de segurança (PERIGO, ATENÇÃO) do manual acerca de perigo de morte e de ferimento e para evitar danos materiais e, considere as informações destacadas sobre o produto (NOTA).

Todas as notas de segurança levam um número corrente que se refere aos capítulos em questão, por ex. 1.1. A tradução das notas em todas as línguas oficiais da CE encontra-se no anexo.



! PERIGO !

1.1

A manutenção e a instalação dos componentes só deverão ser levadas a cabo por pessoal competente na área da electricidade (VDE 1000-10) e obedecendo tanto às normas de prevenção contra acidentes como às normas de instalação (EN 60204-Teil1, prEN 50178).



! PERIGO !

1.2

Premissas indispensáveis para o funcionamento impecável e seguro do produto são transporte, armazenamento, instalação e montagem competentes bem como o manejo correcto do mesmo.

CUIDADO !

1.3

Conversores de accionamento contêm componentes que poderão ser facilmente danificados através de energia electrostática caso os dispositivos não sejam tratados de acordo com as indicações



!PERIGO!

1.4

Os componentes eléctricos já instalados não deverão ser danificados porque podem causar danos pessoais.



! PERIGO !

3.1

Passagem de correntes perigosas caso não existam ligações de condutores de protecção suficientes.
As ligações dos condutores de protecção não devem ser afectadas por influências mecânicas, químicas ou termoquímicas. A ligação tem que encontrar-se permanentemente firme.

! PERIGO !**3.2**

Filtros de corrente contêm condensadores e resistências de descarga que continuam a estar carregados com tensões mesmo após a corrente da rede ter sido desligada, e que podem representar perigo de morte.

Tocar nos bornes de potência apenas passados 10 seg.







A.1.9 Suomi

Käsikirjan varoitusohjeet

Ota huomioon käsikirjan hengenvaaraa ja terveysriskejä sekä tavaravahinkojen välttämistä koskevat turvallisuusohjeet ("VAARA", "HUOMIO"), sekä korostetut tuotetta koskevat tiedot ("Ohje").

Kaikilla turvallisuusohjeilla on kappaleisiin liittyvä, juokseva numero, esim. 1.1 . Liitteestä löytyvät näiden turvallisuusohjeiden vastaavat käännökset kaikilla virallisilla EU-kielillä.

	<p style="text-align: center;">! VAARA ! 1.1</p> <p>Komponenttien huolto ja asennus on annettava sähköalan ammattilaisen tehtäväksi (VDE 1000-10) ja tapaturmantorjunta- sekä asennusohjeet huomioiden (EN 60204-osa1, prEN 50178).</p>
	<p style="text-align: center;">! VAARA ! 1.2</p> <p>Asianmukainen kuljetus, varastointi, sijoitus ja asennus sekä huolellinen käyttö on edellytyksenä tuotteen moitteettomalle ja varmalle toiminnalle.</p>
	<p style="text-align: center;">HUOMIO ! 1.3</p> <p>Käyttömuuntajissa on sähköstaattisesti vaarannettuja rakenneosia, jotka voivat helposti tuhoutua väärin käsiteltäessä.</p>
	<p style="text-align: center;">! VAARA ! 1.4</p> <p>Sisäänrakennettuja sähkökomponentteja ei saa tuhota terveysriskin takia.</p>
	<p style="text-align: center;">! VAARA ! 3.1</p> <p>Riittämättömät suojamaadoitusliitännät aiheuttavat vaarallisia runkovirtoja. Mekaaniset, kemialliset tai sähkökemialliset tekijät eivät saa haitata suojamaadoitusliitännöitä. Liitännän tulee olla pysyvästi kiinteä.</p>
	<p style="text-align: center;">! VAARA ! 3.2</p> <p>Verkkosuodattimissa on kondensaattoreita ja purkausresistansseja, joissa vielä verkkovirran katkaisun jälkeenkin on hengenvaarallisia jännitteitä. Odota vähintään 10 s ennen kuin kosket teholiittimiä työkalulla.</p>

A.1.10 Svenska**Anvisning om risker i handboken**

Beakta de säkerhetsanvisningar som ingår i handboken ("RISKER", "OBSERVERA") över risker för liv och hälsa och hur saksador undviks, samt de specificerade informationerna över produkten ("Anvisning").

Alla säkerhetsanvisningarna är numrerade fortlöpande på samma sätt som kapitlen, t. ex. 1.1. I bilagan finns tillhörande översättningar över säkerhetsanvisningen i alla EU-språk.

! FARA !**1.1**

Underhåll och installation av komponenterna får endast genomföras av behörig elektriker (VDE 1000-10) med beaktande av de olycksfallsförebyggande bestämmelserna och installationsbestämmelserna (EN 60204-Teil1, prEN 50178).

**! FARA !****1.2**

Produktens perfekta och säkra drift förutsätter sakkunnig transport, riktig lagring, uppställning och montage samt noggrann manövrering.

**OBSERVERA !****1.3**

Drivningsfrekvensomformare innehåller elektrostatiskt känsliga komponenter som lätt kan förstöras vid icke sakkunnig hantering.

! FARA !**1.4**

Inbyggda elektriska komponenter får på grund av möjliga hälsorisker inte förstöras.

**! FARA !****3.1**

Farliga kroppsströmmar genom otillräckliga skyddsledarförbindelser. Ingen mekanisk, kemisk eller elektrokemisk påverkan på skyddsledarförbindelserna. Förbindelserna skall sitta fast konstant.

**! FARA !****3.2**

Nätfilter innehåller kondensatorer och urladdningsmotstånd som även när nätspänningen frånkopplats innehåller livsfarlig spänning. Rör vid effektplintarna med ett verktyg först efter min. 10 sekunder!



Ihre Notizen :

Bosch-Automationstechnik

Robert Bosch GmbH
Geschäftsbereich
Automationstechnik
Industriehydraulik
Postfach 30 02 40
D-70442 Stuttgart
Telefax (07 11) 8 11-18 57

Robert Bosch GmbH
Geschäftsbereich
Automationstechnik
Fahrzeughydraulik
Postfach 30 02 40
D-70442 Stuttgart
Telefax (07 11) 8 11-17 98

Robert Bosch GmbH
Geschäftsbereich
Automationstechnik
Pneumatik
Postfach 30 02 40
D-70442 Stuttgart
Telefax (07 11) 8 11-89 17

Robert Bosch GmbH
Geschäftsbereich
Automationstechnik
Montagetchnik
Postfach 30 02 07
D-70442 Stuttgart
Telefax (07 11) 8 11-77 12

Robert Bosch GmbH
Geschäftsbereich
Automationstechnik
Antriebs- und Steuerungstechnik
Postfach 11 62
D-64701 Erbach
Telefax (0 60 62) 78-4 28

Robert Bosch GmbH
Geschäftsbereich
Automationstechnik
Schraub- und Einpreßsysteme
Postfach 11 61
D-71534 Murrhardt
Telefax (0 71 92) 22-1 81

Robert Bosch GmbH
Geschäftsbereich
Automationstechnik
Entgrattechnik
Postfach 30 02 07
D-70442 Stuttgart
Telefax (07 11) 8 11-34 75

Technische Änderungen vorbehalten

Ihr Ansprechpartner

BOSCH



Robert Bosch GmbH
Geschäftsbereich
Automationstechnik
Antriebs- und Steuerungstechnik
Postfach 11 62
D-64701 Erbach
Telefax (0 60 62) 78-4 28